

B

Type

17

Docs

1

Plans

BLD04-6294

Building Permit Number (List all associated with these documents)

2136

Street Number

Bohemian Hwy

Street Name

Occ

Community Code

073-170-017

APN

COUNTY OF SONOMA
PERMIT AND RESOURCE MANAGEMENT DEPARTMENT
 2550 VENTURA AVENUE, SANTA ROSA, CA 95403-2829
 (707) 565-1900 FAX (707) 565-1103

Building Permit Invoice: BLD04-6294

Project Address: 2136 BOHEMIAN HWY OCC
Cross Street: BOHEMIAN LN
APN: 073-170-017

Status: **PREISSUE**
Printed: October 28, 2004
Initialized by: BDAVIS
Activity Type: B-BLD 401

Description: FIRE SPRINKLERS FOR BATH HOUSE AT YOUTH CAMP

Res/Com: R **Insp Area:** 07
Std/Quick: Q **Site Review File #:**
Fire District: OCCIDENTAL CSD ZN2 FIRE **Site Review Fees Paid:** \$0.00

Owner: CATHOLIC YOUTH ORG OF THE ARCHDIOCESE SF
 2255 HAYES ST 4TH FLOOR
 SAN FRANCISCO CA 94117

Applicant: RLS FIRE PROTECTION SYSTEMS
 930 SHILOH RD, BLD 44 STE E
 WINDSOR CA 95492
 707 837 2045

| Occupancy | Type | Valuation: | Sq Feet | Valuation |
|--------------|------------------------|--------------|----------|------------|
| | Totals... | Factor | | \$0.00* |
| Fees: | | | | |
| Item# | Description | Account Code | Tot Fee | Prev. Pmts |
| 119 | FIRE COMMERCIAL REVIEW | 649103-3661 | 630.00 | 210.00 |
| 124 | PLUMBING FEE | 025015-1341 | 53.50 | .00 |
| 140 | TECH ENHANCEMENT FEE | 025015-4040 | 3.95 | 3.15 |
| | | | \$687.45 | \$213.15 |

Total Fees: \$687.45
Total Paid: \$213.15
Balance Due: \$474.30

Refunds are regulated by the California Building Code (CBC) which reads: "Under Section 107.6, CBC, the building official may authorize refunding of not more than 80 percent of the plan review fee paid when an application is withdrawn or canceled before any plan reviewing is done. The building official may authorize refunding of not more than 80 percent of the permit fee paid when no work has been done under the permit. There shall be no refunding of any fee paid except on written application filed by the original permittee not later than 180 days after the date of fee payment."

When validated below, this is your receipt.
This Building Permit shall EXPIRE

PAYMENT REC'D
 \$ 474.30
 APR 25 2005
 PERMIT AND RESOURCE
 MANAGEMENT DEPARTMENT
 COUNTY OF SONOMA

COUNTY OF SONOMA - PERMIT AND RESOURCE MANAGEMENT DEPARTMENT

2550 Ventura Avenue, Santa Rosa, CA 95403 (707) 565-1900 FAX (707) 565-1103

| | |
|--|---------------------|
| Please Print Your Name: <u>RLS Fire Protection Systems</u> | Date Applied: _____ |
|--|---------------------|

INFORMATION WITHIN HEAVY LINE TO BE COMPLETED BY APPLICANT

| | | | |
|--|-------------------------|--------------------------------------|------------------------------------|
| SITE LOCATION INFORMATION - PRINT CLEARLY | | | |
| Site Address: <u>2130 Bohemian Hwy.</u> | City: <u>Occidental</u> | ZIP: <u>95465</u> | |
| Cross-Street: <u>Bohemian Ln.</u> | APN: <u>073-170-017</u> | Project Phone #: <u>707 874-0225</u> | Project Fax #: <u>707 874-0230</u> |
| Directions: _____ | Subd. Name: <u>017</u> | Unit #: _____ | Lot #: _____ |
| Describe Project: <u>Design & install automatic Res. fire sprinkler system</u> | Living Area: _____ | Garage: _____ | Decks: <u>Bathhouse</u> |
| | | | Contract Price: <u>\$1350.00</u> |

| | | | | | |
|--------------------------------------|--------------------------|-------------------|---|--------------------------|-------------------|
| OWNER NAME AND ADDRESS | | | APPLICANT NAME AND ADDRESS | | |
| Name: <u>Frank Bastore - 6640</u> | | | Name: <u>RLS Fire Protection Systems</u> | | |
| Mailing Address: <u>P.O. Box 188</u> | | | Mailing Address: <u>930 Shiloh Rd. Bldg. 44 Ste E</u> | | |
| City: <u>Occidental</u> | State: <u>Ca</u> | ZIP: <u>95465</u> | City: <u>Windsor</u> | State: <u>Ca</u> | ZIP: <u>95492</u> |
| Day Ph: <u>707 874-0238</u> | Fax: <u>707 874-0230</u> | | Day Ph: <u>707 837-2045</u> | Fax: <u>707 837-2047</u> | |

| | | | | | |
|--|--------------------------|-------------------|---|----------------|------------|
| CONTRACTOR INFORMATION | | | OTHER PERSONS (ARCHITECT, ENGINEER, ETC.) | | |
| Company Name: <u>RLS Fire Protection Systems</u> | | | Name: _____ | | |
| Address: <u>930 Shiloh Rd. Bldg. 44, Ste. E</u> | | | Address: _____ | | |
| City: <u>Windsor</u> | State: <u>Ca</u> | ZIP: <u>95492</u> | City: _____ | State: _____ | ZIP: _____ |
| Day Ph: <u>707 837-2045</u> | Fax: <u>707 837-2047</u> | | Day Ph: () _____ | Fax: () _____ | |

WORKER'S COMPENSATION DECLARATION

I hereby affirm under penalty of perjury one of the following declarations:

I have and will maintain a certificate of consent to self-insure for worker's compensation, as provided for by Section 3700 of the Labor Code, for the performance of the work for which this permit is issued.

I have and will maintain worker's compensation insurance, as required by Section 3700 of the Labor Code, for the performance of the work for which this permit is issued. My worker's compensation insurance carrier and policy number are:

Carrier: State Compensation Ins. Fund
 Policy No.: 11074403-04

(This section need not be completed if the permit is for one hundred dollars (\$100) or less.)

I certify that in the performance of the work for which this permit is issued, I shall not employ any person in any manner so as to become subject to the worker's compensation laws of California, and agree that if I should become subject to the worker's compensation provisions of Section 3700 of the Labor Code, I shall forthwith comply with those provisions.

Exp. Date: 02/08/05

CONSTRUCTION LENDING DECLARATION

I hereby affirm under penalty of perjury that there is a construction lending agency for the performance of the work for which this permit is issued. (Sec. 3097, Civ. C.)

Lenders Name: N/A
 Lenders Address: _____

WARNING: FAILURE TO SECURE WORKER'S COMPENSATION COVERAGE IS UNLAWFUL, AND SHALL SUBJECT AN EMPLOYER TO CRIMINAL PENALTIES AND CIVIL FINES UP TO ONE HUNDRED THOUSAND DOLLARS (\$100,000). IN ADDITION TO THE COST OF COMPENSATION, DAMAGES AS PROVIDED FOR IN SECTION 3700 OF THE LABOR CODE, INTEREST, AND ATTORNEY'S FEES.

OWNER-BUILDER DECLARATION

I hereby affirm under penalty of perjury that I am exempt from the Contractor's License Law for the following reason (Sec. 7031.5, Business and Professions Code): Any city or county which requires a permit to construct, alter, improve, demolish, or repair any structure, prior to its issuance, also requires the applicant for such permit to file a signed statement that he or she is exempt pursuant to the provisions of the Contractor's License Law (Chapter 9 (commencing with Section 7000) of Division 3 of the Business and Professions Code) or that he or she is exempt therefrom and the basis for the alleged exemption. Any violation of Section 7031.5 by any applicant for a permit subjects the applicant to a civil penalty of not more than five hundred dollars (\$500):

I, as owner of the property, or my employees with wages as their sole compensation, will do the work, and the structure is not intended or offered for sale (Sec. 7044 Business and Professions Code). The Contractor's License Law does not apply to an owner of property who builds or improves thereon, and who does such work himself or herself or through his or her own employees, provided that such improvements are not intended or offered for sale. If, however, the building or improvement is sold within one year of completion, the owner-builder will have the burden of proving that he or she did not build or improve for the purpose of sale.)

I, as owner of the property, am exclusively contracting with licensed contractors to construct the project (Sec. 7044, Business and Professions Code). The Contractor's License Law does not apply to an owner of property who builds or improves thereon, and who contracts for such projects with a contractor(s) licensed pursuant to the Contractor's License Law.)

I am exempt under Sec. _____ B & P.C. for this reason _____

Date _____ Owner _____

LICENSED CONTRACTOR'S DECLARATION

I hereby affirm under penalty of perjury that I am licensed under provisions of Chapter 9 (commencing with Section 7000) of Division 3 of the Business and Professions Code, and my license is in full force and effect.

Lic. Class: C1E Lic. No.: 5616656

Exp. Date: 02/08/05 Contractor: _____

ASBESTOS DECLARATION

Written asbestos notification pursuant to Part 61 of Title 40 of the Code of Federal Regulations is required when asbestos exists in buildings, or portions thereof, undergoing demolition. I hereby declare that demolition authorized by this permit is from construction that does does not contain asbestos, or that no demolition is authorized by this permit.

I certify that I have read this application and affirm under penalty of perjury that the above information is correct. I agree to comply with all local Ordinances and State laws relating to building construction. I hereby authorize representatives of the County of Sonoma to enter upon the above-mentioned property for inspection purposes. If, after making the Certificate of Exemption for the Worker's Compensation provision of the Labor Code I should become subject to such provisions, I will forthwith comply. In the event I do not comply with the Workman's Compensation law, this permit shall be deemed revoked.

PERMITTEE SIGNATURE
930 Shiloh Rd. Bldg. 44, Ste. E
 ADDRESS Windsor, Ca 95492 ZIP _____

Contractor Owner Other Licensed Professional

FOR DEPARTMENT USE

Zoning _____ File No. _____ Acres _____

Existing Use/Structures _____

Proposed Use/Structures _____

Zoning Min. Yard Requirements: Front _____ Left _____ Right _____ Back _____

NOTE: Fire Safe Standards require all parcels greater than 1 Acre to have a min. 30' setback unless mitigated. Mitigation Required Address subject to change

Approval for Permit Issuance: _____ Approval for Occupancy: _____

By: _____ Date: _____

Conditions: _____

Sewer Connection: Available Fees Paid

Approved by: _____ Date: _____

Road Encroachment: Fees Paid

Approved by: _____ Date: _____

Septic System Permit/Clearance # _____

Approved by: _____ Date: _____

Flood Zone: Yes No 100 Year Flood Elevation: _____

Site Review _____

Drainage Review: _____

Approved by: _____ Date: _____

Fire: _____

Approved by: _____ Date: _____

Code Enforcement Violation Yes No Violation # _____

This permit is limited to _____ days.

Work Authorized: _____

| | | |
|---|------------------------------------|---|
| <input checked="" type="checkbox"/> Plans Approved | <input type="checkbox"/> Post FIRM | <input type="checkbox"/> Alquist-Prilo Report Available |
| <input type="checkbox"/> No Plans Subject to Field Inspection | <input type="checkbox"/> Pre FIRM | <input type="checkbox"/> Geotechnical report Available |
| Plan No. <u>10/28/04</u> | Type of Construction _____ | Occupancy _____ |
| Date: <u>10/28/04</u> | No. of Stories _____ | No. of Bedrooms _____ |
| Permit Cleared for Issuance By: <u>CUU</u> | Auto. Fire Sprinklers Req'd _____ | Certificate of Occupancy _____ |

Machining Stamp for Permit Fee

PAYMENT REC'D

\$ 1000

APR 25 2005

PERMIT AND RESOURCE MANAGEMENT DEPARTMENT
 COUNTY OF SONOMA

Final Date: _____ Inspector: _____

THIS PERMIT SHALL EXPIRE IN THREE (3) YEARS FROM DATE FEES ARE PAID UNLESS OTHERWISE NOTED BY CODE ENFORCEMENT

Distribution: White - File Canary - Applicant Pink - Audit Copy Blue - Assessor Cardstock - Inspector

JOB ADDRESS: 2130 Bohemian Hwy
 PERMIT NUMBER: BR04-10294
 INSPECTION AREA: 7

| 131) | SPECIAL INSPECTION REQUIRED | <input type="checkbox"/> YES | <input type="checkbox"/> NO | IF YES, SEE ADDITIONAL SHEET |
|------|--------------------------------------|------------------------------|--------------------------------------|---|
| | INSPECTION RECORD | DATE | NAME | REMARKS |
| 101) | ROUGH GRADING | | | |
| 103) | FOUNDATION | | | |
| | FORMS/SETBACK | | | |
| | FOOTING | | | |
| | WALLS | | | |
| 106) | UFER GROUND # | | | |
| 104) | CAISSONS/PIERS | | | |
| 105) | SLAB | | | |
| 107) | UNDERGROUND UTILITIES | | | |
| 110) | MASONRY | | | |
| 109) | RETAINING WALLS | | | |
| 113) | FIREPLACE | | | |
| | HEARTH/PROTECTION | | | |
| | THROAT | | | |
| 114) | CHIMNEY | | | |
| 120) | UNDERFLOOR/UNDERSLAB | | | |
| 115) | HYDRONICS | | | |
| 116) | U/F ELECTRICAL | | | |
| 117) | U/F MECHANICAL | | | |
| 118) | U/F PLUMBING | | | |
| 119) | U/F FRAMING | | | |
| 139) | U/F INSULATION | | | |
| 126) | SHEAR WALLS | | | |
| | <input type="checkbox"/> INTERIOR | | <input type="checkbox"/> EXTERIOR | |
| 127) | DIAPHRAGMS | | | |
| | <input type="checkbox"/> ROOF | | <input type="checkbox"/> FLOOR | |
| 134) | SIDING/SHEATHING | | | |
| 125) | HOLD DOWNS | | | |
| 132) | CLOSE-IN | | | |
| 122) | ROUGH ELECTRICAL | | | |
| 123) | ROUGH MECHANICAL | | | |
| 124) | ROUGH PLUMBING | | | |
| 128) | ROUGH FRAME | | | |
| 160) | SMOKE DETECTORS | | | |
| 139) | INSULATION | | | |
| 142) | WALLBOARD | | | |
| 143) | FIREWALLS | | | |
| 135) | STUCCO/PLASTER | | | |
| | <input type="checkbox"/> LATH | | <input type="checkbox"/> SCRATCH | |
| 137) | ROOFING | | | |
| 130) | TUB/SHOWER PAN | | | |
| 162) | FIRE DAMPERS/DOORS | | | |
| 164) | SUSPENDED CEILING | | | |
| | <input type="checkbox"/> ROUGH ELEC. | | <input type="checkbox"/> ROUGH MECH. | |
| 165) | EXITING - RAMPS/STAIRS | | | |
| 163) | HANDRAILS/GUARDRAILS | | | |
| | CORRIDORS/DOORS | | | |
| 166) | ACCESSIBILITY COMPLIANCE | | | 650) SUSMP INSPECTION |
| 144) | WATER TANKS | | | 651) NPDES EROSION COMPLIANCE |
| | <input type="checkbox"/> SLAB | | <input type="checkbox"/> WALLS | 652) NPDES SEDIMENT COMPLIANCE |
| 170) | TEMPORARY OCCUPANCY | | | 653) NPDES DOCS/SWPPP |
| 171) | TEMPORARY ELECTRICAL | | | FIRE INSPECTION REQUIRED |
| 172) | TEMPORARY GAS | | | <input checked="" type="checkbox"/> Yes <input type="checkbox"/> No |
| 174) | ELECTRIC METER AUTHORIZATION | | | 759) KNOX BOX |
| 152) | PANEL BOARDS/SERVICE | | | 760) PROPANE TANK HOLD DOWNS |
| 189) | SEPTIC ELECTRIC FINAL | | | 770) SPRINKLER FINAL |
| 175) | GAS METER AUTHORIZATION | | | 771) ABOVEGROUND HYDROSTATIC |
| 153) | GAS PRESSURE TEST | | | 772) UNDERGROUND HYDROSTATIC |
| | HOUSE | | YARD | 773) UNDERGROUND FLUSH |
| 190) | MANUF. HOME FOUNDATION | | | 774) THRUST BLOCKS |
| 191) | MANUF. HOME INSTALLATION | | | 775) PIPE WELD |
| | CONTINUITY | | | 776) HYDRANTS/APPLIANCES |
| | STAIRS/SKIRTS | | | 777) PUMP ACCEPTANCE |
| | RIDGE BOLTING | | | 778) WATER SUPPLY/TANK |
| 193) | MANUF. HOME COND. FINAL | | | 779) ALARM SYSTEM |
| | SWIMMING POOLS | | | 780) HOOD & DUCT SYSTEM |
| 194) | PRE-GUNITE | | | 781) ABOVEGROUND TANK/DISPENSER |
| 195) | PRE-DECK | | | 198) FIRE FINAL <i>6/25/05 SH B4 SJK</i> |
| 196) | PRE-PLASTER/FENCE | | | CLEARANCES: |
| 197) | VINYL/FIBERGLASS POOL EXCAVATION | | | FIRE <input type="checkbox"/> Local <input type="checkbox"/> County |
| 102) | GRADING FINAL | | | HEALTH DEPARTMENT |
| 176) | ELECTRICAL FINAL | | | ZONING |
| 177) | MECHANICAL FINAL | | | SANITATION |
| 178) | PLUMBING FINAL | | | |
| 199) | FINAL | 6/25/05 SJK | | PLAN RETENTION REQUIRED? |
| | OCCUPANCY (OK TO OCCUPY) | | | <input type="checkbox"/> Yes <input type="checkbox"/> No |

PERMIT # BUD004-10294

RLS Fire Protection Systems
930 Shiloh Road Bladg. 44 Ste. E
Windsor, California 95492

HYDRAULIC CALCULATIONS

FOR

C.Y.O. BATH HOUSE
2136 BOHEMIAN HIGHWAY
OCCIDENTAL, CALIFORNIA

FILE NUMBER: 040722.SDF
DATE: OCTOBER 8, 2004

-DESIGN DATA-

OCCUPANCY CLASSIFICATION: NFFPA 13D

SPRINKLER SPACING: 256sq. ft./spklr. (max)

SPRINKLER SPECIFICATIONS: CENTRAL LFII K=4.9

PIPE SPECIFICATIONS: COPPER TYPE M (HWC = 150)
CPVC (HWC = 150)

NUMBER OF SPRINKLERS CALCULATED: 2

FLOW AND PRESSURE (@BASR): 26.5gpm @ 34.2psi

TOTAL SPRINKLER WATER FLOW REQUIRED: 26.5gpm

TOTAL WATER REQUIRED (incl. hose): 26.5gpm

NAME OF CONTRACTOR:

DESIGN / LAYOUT BY: Ron Scoggins

AUTHORITY HAVING JURISDICTION: Sonoma County Fire Services

FIRE DEPARTMENT TELEPHONE NUMBER: (707) 565-1152

NOTES: 2 head calc at 16 x 16 ft.

Water pressure is provided by elevated tanks totaling 127,000 gallons

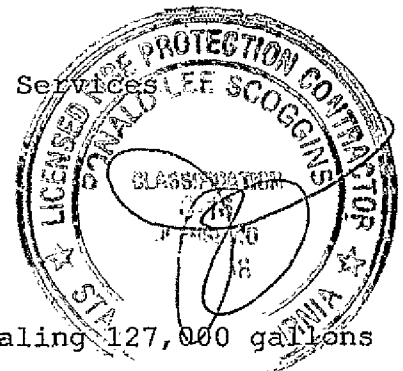

CALCULATIONS BY HASS COMPUTER PROGRAM (LICENSE # 414C756)
HRS SYSTEMS, INC.

JOB TITLE: C.Y.O. BATH HOUSE
 WATER SUPPLY DATA

| SOURCE NODE TAG | STATIC PRESS. (PSI) | RESID. PRESS. @ (PSI) | FLOW (GPM) | AVAIL. PRESS. (PSI) | TOTAL @ DEMAND (GPM) | REQ'D PRESS. (PSI) |
|-----------------------|---------------------------|-----------------------------|---------------|---------------------------|----------------------------|--------------------------|
| 1 | 130.0 | 20.0 | 1500.0 | 129.9 | 26.5 | 39.4 |

AGGREGATE FLOW ANALYSIS:

| | |
|--|----------|
| TOTAL FLOW AT SOURCE | 26.5 GPM |
| TOTAL HOSE STREAM ALLOWANCE AT SOURCE | 0.0 GPM |
| OTHER HOSE STREAM ALLOWANCES | 0.0 GPM |
| TOTAL DISCHARGE FROM ACTIVE SPRINKLERS | 26.5 GPM |

NODE ANALYSIS DATA

| NODE TAG | ELEVATION (FT) | NODE TYPE | PRESSURE (PSI) | DISCHARGE (GPM) |
|----------|-------------------|-----------|-------------------|--------------------|
| 1 | 0.0 | SOURCE | 39.4 | 26.5 |
| 2 | 1.0 | - - - - | 36.0 | - - - |
| 3 | 1.0 | - - - - | 34.2 | - - - |
| 4 | 3.0 | - - - - | 32.2 | - - - |
| 10 | 9.0 | - - - - | 8.5 | - - - |
| 1 | 9.0 | K= 4.90 | 7.5 | 13.5 |
| 2 | 9.0 | K= 4.90 | 7.0 | 13.0 |

JOB TITLE: C.Y.O. BATH HOUSE

PIPE DATA

| PIPE TAG | Q(GPM) | DIA(IN) | LENGTH | PRESS. |
|----------|----------------------------|---------|------------|----------------------------|
| END | VEL(FPS) | HW(C) | (FT) | SUM. |
| NODES | (FT) | (K) | (PSI) | (PSI) |
| Pipe: 1 | 26.5 | 1.055 | PL 2.00 | PF 2.9 |
| 1 | 0.0 | SRCE | 39.4 (N/A) | 9.7 150 FTG ETC PE -0.4 |
| 2 | 1.0 | 0.0 | 36.0 0.0 | 0.141 TL 20.80 PV 0.6 |
| Pipe: 2 | FIXED PRESSURE LOSS DEVICE | | | |
| 2 | 1.0 | 0.0 | 36.0 0.0 | 1.8 psi, 26.5 gpm |
| 3 | 1.0 | 0.0 | 34.2 0.0 | |
| Pipe: 3 | 26.5 | 1.055 | PL 2.00 | PF 1.2 |
| 3 | 1.0 | 0.0 | 34.2 0.0 | 9.7 150 FTG 2E PE -0.9 |
| 4 | 3.0 | 0.0 | 32.2 0.0 | 0.141 TL 8.40 PV 0.6 |
| Pipe: 4 | 26.5 | 0.874 | PL 38.00 | PF 21.1 |
| 4 | 3.0 | 0.0 | 32.2 0.0 | 14.2 150 FTG 4ET3R PE -2.6 |
| 10 | 9.0 | 0.0 | 8.5 0.0 | 0.352 TL 60.00 PV 1.3 |
| Pipe: 5 | 13.5 | 0.874 | PL 2.50 | PF 1.0 |
| 10 | 9.0 | 0.0 | 8.5 0.0 | 7.2 150 FTG ET PE 0.0 |
| 101 | 9.0 | 4.9 | 7.5 13.5 | 0.101 TL 9.50 PV 0.3 |
| Pipe: 6 | 13.0 | 0.874 | PL 10.50 | PF 1.5 |
| 10 | 9.0 | 0.0 | 8.5 0.0 | 7.0 150 FTG ER PE 0.0 |
| 102 | 9.0 | 4.9 | 7.0 13.0 | 0.094 TL 15.50 PV 0.3 |

NOTES:

- Calculations were performed by the HASS 7.1 computer program under license no. 49020756 granted by HRS Systems, Inc. 4792 LaVista Road Tucker, GA 30084
- The system has been calculated to provide an average imbalance at each node of 0.014 gpm and a maximum imbalance at any node of 0.085 gpm.
- Velocity pressures are printed for information only, and are not used in balancing the system. Maximum water velocity is 14.2 ft/sec at pipe 4.

(4) PIPE FITTINGS TABLE

Pipe Table Name: RLS.PIP

JOB TITLE: C.Y.O. BATH HOUSE

PAGE: C MATERIAL: CPVC HWC: 150

| Diameter (in) | Equivalent Fitting Lengths in Feet | | | | | | | |
|------------------|------------------------------------|------|-------|------|--------|--------|--------|--------|
| | E | T | F | N | R | B | C | G |
| | Ell | Tee | 45Ell | Adap | RunTee | BfyVlv | ChlVlv | GatVlv |
| 0.874 | 4.00 | 3.00 | 1.00 | 1.00 | 1.00 | 7.80 | 10.10 | 2.00 |

PAGE: M MATERIAL: CopM HWC: 150

| Diameter (in) | Equivalent Fitting Lengths in Feet | | | | | | | | |
|------------------|------------------------------------|------|-------|--------|--------|--------|--------|--------|-------|
| | E | T | F | L | A | C | G | B | D |
| | Ell | Tee | 45Ell | LngEll | AlmChk | ChkVlv | GatVlv | BfyVlv | DPVlv |
| 1.055 | 3.20 | 7.80 | 1.60 | 3.20 | 15.60 | 7.80 | 1.60 | 9.40 | 15.60 |

JOB TITLE: C.Y.O. BATH HOUSE

WATER SUPPLY ANALYSIS

Static: 130.00 psi Resid: 20.00 psi Flow: 1500.0 gpm

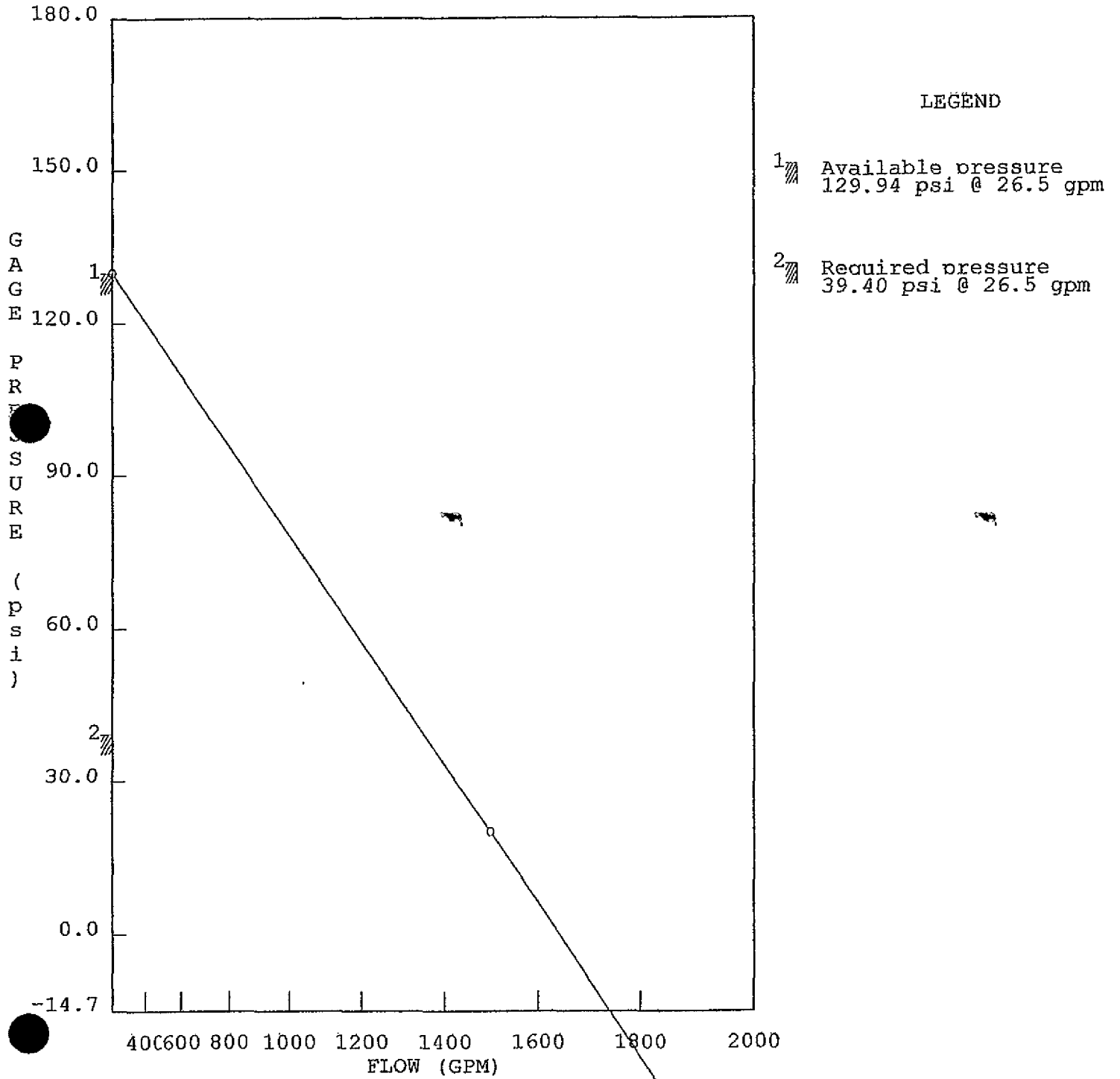

Series LFII Residential Pendent Sprinklers 4.9 K-factor

General Description

The Series LFII (TY2234) Residential Pendent Sprinklers are decorative, fast response, frangible bulb sprinklers designed for use in residential occupancies such as homes, apartments, dormitories, and hotels. When aesthetics and optimized flow characteristics are the major consideration, the Series LFII (TY2234) should be the first choice.

The Series LFII are to be used in wet pipe residential sprinkler systems for one- and two-family dwellings and mobile homes per NFPA 13D; wet pipe residential sprinkler systems for residential occupancies up to and including four stories in height per NFPA 13R; or, wet pipe sprinkler systems for the residential portions of any occupancy per NFPA 13.

The Series LFII (TY2234) has a 4.9 (70,6) K-factor that provides the required residential flow rates at reduced pressures, enabling smaller pipe sizes and water supply requirements.

The recessed version of the Series LFII (TY2234) is intended for use in areas with finished ceilings. It employs a two-piece Style 20 Recessed Escutcheon. The Recessed Escutcheon provides 1/4 inch (6,4 mm) of recessed

adjustment or up to 1/2 inch (12,7 mm) of total adjustment from the flush ceiling position. The adjustment provided by the Recessed Escutcheon reduces the accuracy to which the pipe nipples to the sprinklers must be cut.

The Series LFII (TY2234) has been designed with heat sensitivity and water distribution characteristics proven to help in the control of residential fires and to improve the chance for occupants to escape or be evacuated.

WARNINGS

The Series LFII (TY2234) Residential Pendent Sprinklers described herein must be installed and maintained in compliance with this document, as well as with the applicable standards of the National Fire Protection Association, in addition to the standards of any other authorities having jurisdiction. Failure to do so may impair the performance of these devices.

The owner is responsible for maintaining their fire protection system and devices in proper operating condition. The installing contractor or sprinkler manufacturer should be contacted with any questions.

Sprinkler/Model Identification Number

SIN TY2234

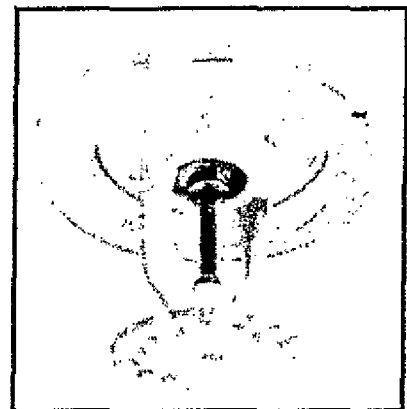
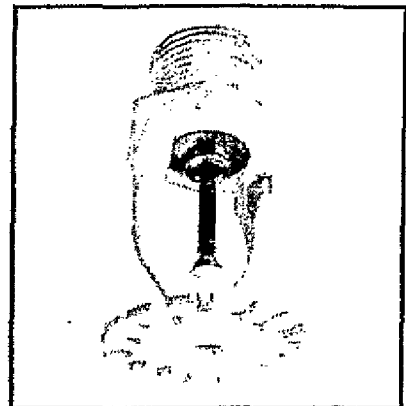

IMPORTANT

Always refer to Technical Data Sheet TFP700 for the "INSTALLER WARNING" that provides cautions with respect to handling and installation of sprinkler systems and components. Improper handling and installation can permanently damage a sprinkler system or its components and cause the sprinkler to fail to operate in a fire situation or cause it to operate prematurely.

| Maximum Coverage Area (a) Ft. x Ft. (m x m) | Maximum Spacing Ft. (m) | Minimum Flow (b) and Residual Pressure For Horizontal Ceiling (Max. 2 Inch Rise for 12 Inch Run) | Minimum Flow (b) and Residual Pressure For Sloped Ceiling (Greater Than 2 Inch Rise Up To Max. 4 Inch Rise for 12 Inch Run) | | Minimum Flow (b) and Residual Pressure For Sloped Ceiling (Greater Than 4 Inch Rise Up To Max. 8 Inch Rise for 12 Inch Run) | |
|---|-------------------------------|--|---|--|---|--|
| | | 155°F/68°C or 175°F/79°C | 155°F/68°C | 175°F/79°C | 155°F/68°C | 175°F/79°C |
| 12 x 12 (3,7 x 3,7) | 12 (3,7) | 13 GPM (49,2 LPM) 7.0 psi (0,48 bar) | 13 GPM (49,2 LPM) 7.0 psi (0,48 bar) | 17 GPM (64,3 LPM) 12.0 psi (0,83 bar) | 13 GPM (49,2 LPM) 7.0 psi (0,48 bar) | 18 GPM (68,1 LPM) 13.5 psi (0,93 bar) |
| 14 x 14 (4,3 x 4,3) | 14 (4,3) | 13 GPM (49,2 LPM) 7.0 psi (0,48 bar) | 13 GPM (49,2 LPM) 7.0 psi (0,48 bar) | 17 GPM (64,3 LPM) 12.0 psi (0,83 bar) | 13 GPM (49,2 LPM) 7.0 psi (0,48 bar) | 18 GPM (68,1 LPM) 13.5 psi (0,93 bar) |
| 16 x 16 (4,9 x 4,9) | 16 (4,9) | 13 GPM (49,2 LPM) 7.0 psi (0,48 bar) | 13 GPM (49,2 LPM) 7.0 psi (0,48 bar) | 17 GPM (64,3 LPM) 12.0 psi (0,83 bar) | 13 GPM (49,2 LPM) 7.0 psi (0,48 bar) | 18 GPM (68,1 LPM) 13.5 psi (0,93 bar) |
| 18 x 18 (5,5 x 5,5) | 18 (5,5) | 17 GPM (64,3 LPM) 12.0 psi (0,83 bar) | 17 GPM (64,3 LPM) 12.0 psi (0,83 bar) | 17 GPM (64,3 LPM) 12.0 psi (0,83 bar) | 17 GPM (64,3 LPM) 12.0 psi (0,83 bar) | 23 GPM (87,1 LPM) 22.0 psi (1,52 bar) |
| 20 x 20 (6,1 x 6,1) | 20 (6,1) | 20 GPM (75,7 LPM) 16.7 psi (1,15 bar) | 20 GPM (75,7 LPM) 16.7 psi (1,15 bar) | 20 GPM (75,7 LPM) 16.7 psi (1,15 bar) | 21 GPM (79,5 LPM) 18.4 psi (1,27 bar) | N/A |

(a) For coverage area dimensions less than or between those indicated, it is necessary to use the minimum required flow for the next highest coverage area for which hydraulic design criteria are stated.

(b) Requirement is based on minimum flow in GPM (LPM) from each sprinkler. The associated residual pressures are calculated using the nominal K-factor. Refer to Hydraulic Design Criteria Section for details.

TABLE A
NFPA 13D AND NFPA 13R HYDRAULIC DESIGN CRITERIA FOR THE SERIES LFII (TY2234)
RESIDENTIAL PENDENT AND RECESSED PENDENT SPRINKLERS

Technical Data

Approvals:
UL and C-UL Listed. NYC Approved under MEA 44-03-E.

Maximum Working Pressure:
175 psi (12,1 bar)

Discharge Coefficient:
K = 4.9 GPM/psi^{1/2} (70,6 LPM/bar^{1/2})

Temperature Rating:
155°F/68°C or 175°F/79°C

Finishes:
White Polyester Coated,
Chrome Plated, or Natural Brass

Physical Characteristics:
Frame Brass
Button Bronze
Sealing Assembly Beryllium Nickel w/Teflon†
Bulb 3 mm dia. Glass
Compression Screw Bronze
Deflector Bronze
Ejection Spring Stainless Steel

†DuPont Registered Trademark

Operation

The glass Bulb contains a fluid that expands when exposed to heat. When the rated temperature is reached, the fluid expands sufficiently to shatter the glass Bulb allowing the sprinkler to activate and flow water.

Design Criteria

The Series LFII (TY2234) Residential Pendent Sprinklers are UL and C-UL Listed for installation in accordance with the following criteria.

NOTE

When conditions exist that are outside the scope of the provided criteria, refer to the Residential Sprinkler Design Guide TFP490 for the manufacturer's recommendations that may be acceptable to the local Authority having Jurisdiction.

System Type. Only wet pipe systems may be utilized.

Hydraulic Design. The minimum required sprinkler flow rate for systems designed to NFPA 13D or NFPA 13R are given in Table A as a function of temperature rating and the maximum allowable coverage areas. The sprinkler flow rate is the minimum required discharge from each of the total

number of "design sprinklers" as specified in NFPA 13D or NFPA 13R.

For systems designed to NFPA 13, the number of design sprinklers is to be the four most hydraulically demanding sprinklers. The minimum required discharge from each of the four sprinklers is to be the greater of the following:

- The flow rates given in Table A for NFPA 13D and 13R as a function of temperature rating and the maximum allowable coverage area.
- A minimum discharge of 0.1 gpm/sq. ft. over the "design area" comprised of the four most hydraulically demanding sprinklers for the actual coverage areas being protected by the four sprinklers.

Obstruction To Water Distribution. Locations of sprinklers are to be in accordance with the obstruction rules of NFPA 13 for residential sprinklers.

Operational Sensitivity.

- For "Horizontal Ceilings" (maximum 2 inch rise for 12 inch run), the sprinklers are to be installed with a deflector to ceiling distance of 1-3/8 to 8 inches or in the recessed position using only the Style 20 Recessed Escutcheon as shown in Figure 2.

NOTE

So as to help avoid obstructions to water distribution, a maximum 12 inch deflector-to-ceiling distance is permitted for NFPA 13D and NFPA 13R appli-

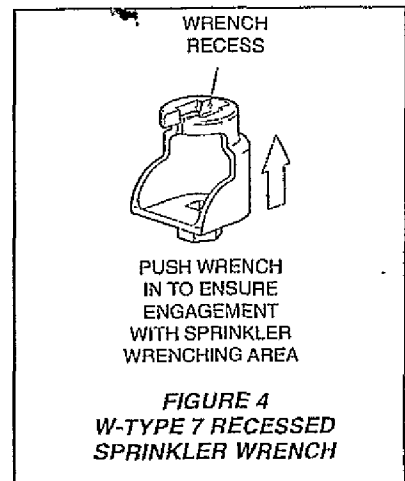
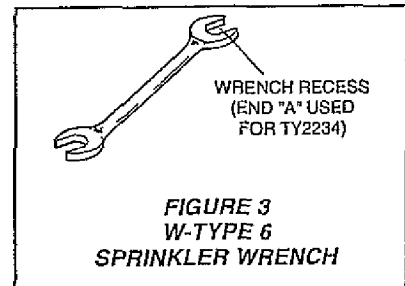
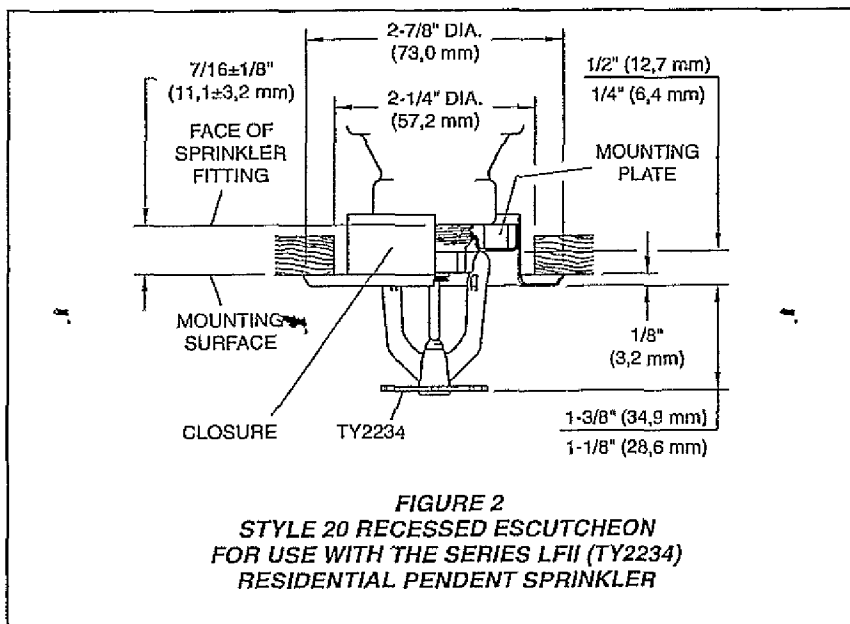
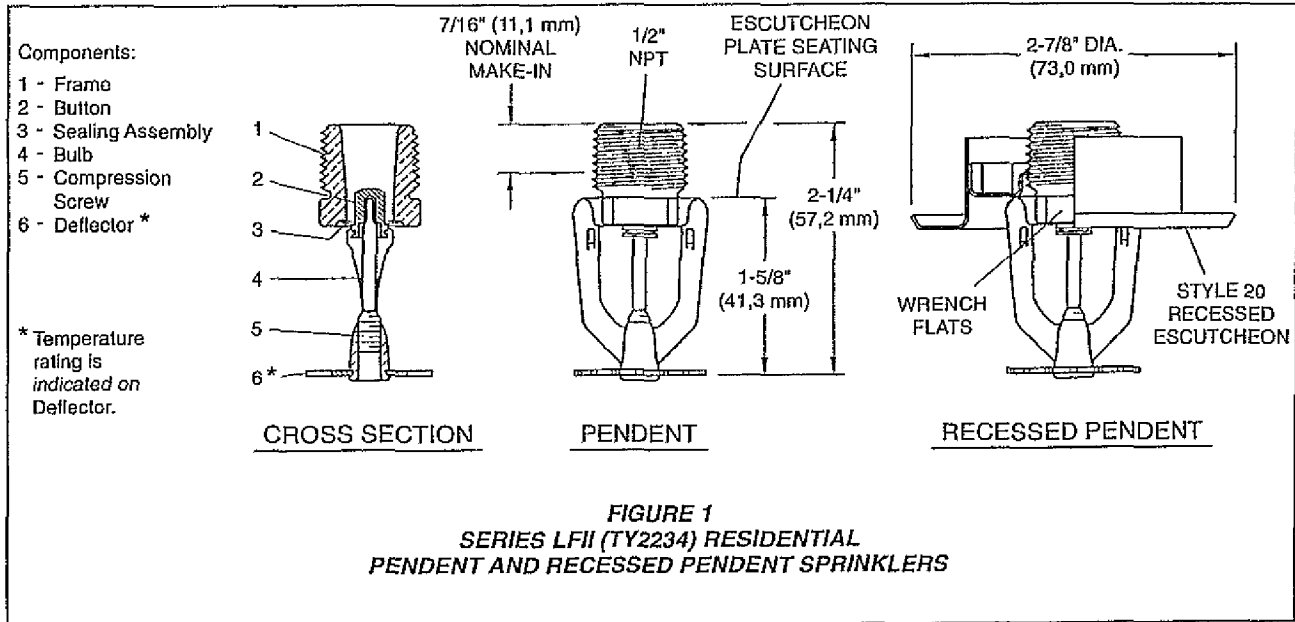

locations where the sprinklers are located in closets.

- For "Sloped Ceilings" (greater than 2 inch rise up to 8 inch rise for 12 inch run), the sprinklers are to be installed with a deflector to ceiling distance of 1-3/8 to 4 inches or in the recessed position using only the Style 20 Recessed Escutcheon as shown in Figure 2

A) being hydraulically calculated (e.g., maximum 12 feet for a 12 ft. x 12 ft. coverage area, or 20 feet for a 20 ft. x 20 ft. coverage area).

Sprinkler Spacing. The minimum spacing between sprinklers is 8 feet (2,4 m). The maximum spacing between sprinklers cannot exceed the length of the coverage area (Ref. Table

Beam Ceiling Design Criteria

The Series LFII (TY2234) Residential Pendent Sprinklers are UL and C-UL Listed for installation in residential occupancies with horizontal ceilings (i.e., slopes up to a 2 inch rise over a 12 inch run) with beams when installed in accordance with the following criteria:

General Information. The basic concept of this protection scheme is to locate the sprinklers on the underside of the beams, Ref. Figure 5, (not in the beam pockets); to identify the main beams that principally run in one direction as "primary beams"; and, to identify the beams that run principally perpendicular to the main beams, as may be present (or in some cases may be necessary for proper sprinkler protection), as "secondary beams".

Primary and Secondary Beam Types. Solid surface, solid or hollow core, combustible or non-combustible.

Primary and Secondary Beam Positioning. Directly attached to the underside of a combustible or non-combustible smooth ceiling at any elevation.

Primary Beam Cross-Section: Maximum depth of 14 inches and the maximum width is unlimited. The cross-sectional shape of the primary beam may be rectangular to circular.

Secondary Beam Cross-Section. Maximum depth to be no greater than the primary beam and the maximum width is unlimited. The cross-sectional shape of the secondary beam may be rectangular to circular.

Primary Beam Spacing. The primary beams (Fig. 6A) are to be 3 ft. - 4 in. to 6 ft. from the compartment wall to center of the nearest beam and from center to center between beams.

Secondary Beam Spacing. The secondary beams principally run perpendicular to the primary beams.

Secondary beams of a depth equal to the primary beam must be placed so that the beam pockets created by the primary beams do not exceed 20 feet in length (Fig. 6B).

NOTE

When the beam pockets created by the primary beams exceed 20 feet in length, the installation will require the use of secondary beams as described above. Otherwise, secondary beams need not be present.

Secondary beams of a cross-sectional depth greater than one-quarter the

depth of the primary beams are to be a minimum of 3 ft. - 4 in. from the compartment wall to center of the nearest beam and from center to center between beams (Fig. 6C).

Secondary beams of a cross-sectional depth no greater than one-quarter the depth of the primary beams may be placed at any compartment wall to center of the nearest beam distance and from any center to center distance between beams (Fig. 6C).

Lintels. Lintels over doorways exiting the compartment must be present. The minimum height for the lintels is 8 inches or no less than the depth of the Primary Beams, whichever is greater.

Sprinkler Types. Series LFII (TY2234), 155F and 175F, Pendent and Recessed Pendent Residential Sprinklers.

Sprinkler Coverage Area and Hydraulic Design. The sprinkler coverage areas and hydraulic design criteria as presented in the Table A for "Horizontal Ceilings" are to be applied.

Sprinkler Position. The deflector to bottom of primary beams for the Series LFII (TY2234) Pendent Sprinklers or Series LFII (TY2234) Recessed Pendent Sprinklers is to be 1-1/4 to 1-3/4 inches (Fig. 5A). The vertical centerline of the Series LFII (TY2234) Pendent Sprinklers is to be no greater than half the primary beam cross-sectional width plus 2 inches from the centerline of the primary beam (Fig 5B).

NOTES

Core drilling of beams to allow the installation of sprinkler drops requires consulting with a structural engineer.

Where core drilling is not permitted, the previously stated sprinkler position criteria for the Series LFII (TY2234) Pendent Sprinklers allows for the sprinkler drop to be placed adjacent to the primary beam.

Beam and Soffit Arrangements. A soffit is permitted to be placed around the perimeter of a compartment with the beam arrangement within the soffit area (Fig.7).

The cross-section of the soffit may be any size as long as it does not create an obstruction to water distribution per the obstruction rules of NFPA 13 for residential sprinklers.

When soffits are present, the previously provided 3 ft. - 4 in. to 6 ft. "compartment wall to adjacent beam" distance for the primary and secondary beams is to be measured from the face of the soffit as opposed to the compartment wall.

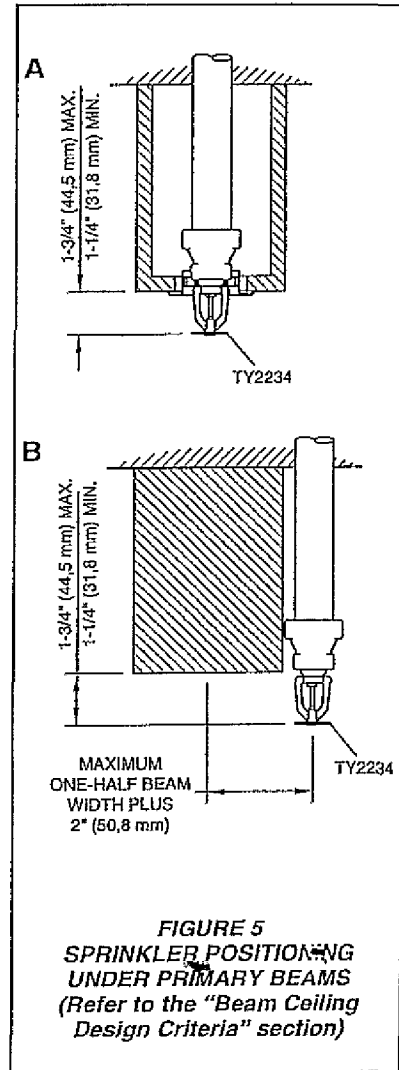

FIGURE 5
SPRINKLER POSITIONING
UNDER PRIMARY BEAMS
(Refer to the "Beam Ceiling
Design Criteria" section)

NOTE

Although the distance to the beams is measured from the face of the soffit, the sprinkler coverage area is to be measured from the compartment wall.

ALL FIGURES:
DISTANCES ARE
MEASURED TO
COMPARTMENT
WALL FACES AND
TO CENTERLINES
OF BEAMS

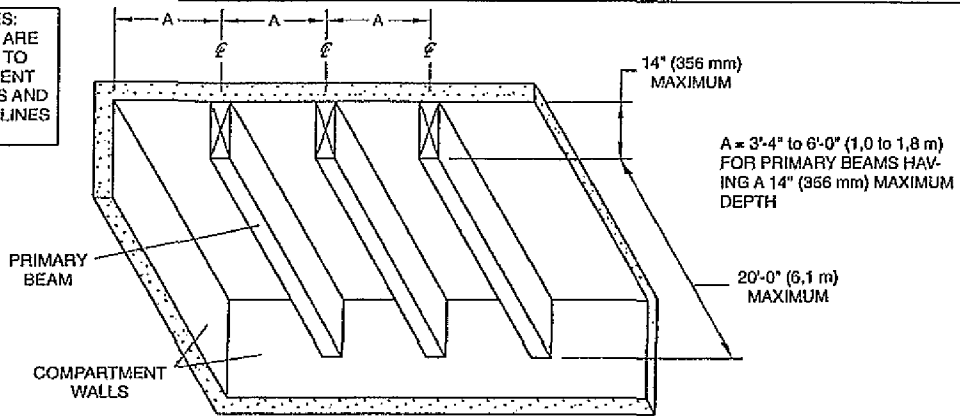

FIGURE 6A
PRIMARY BEAM SPANS UP TO 20'-0" (6,1 m)

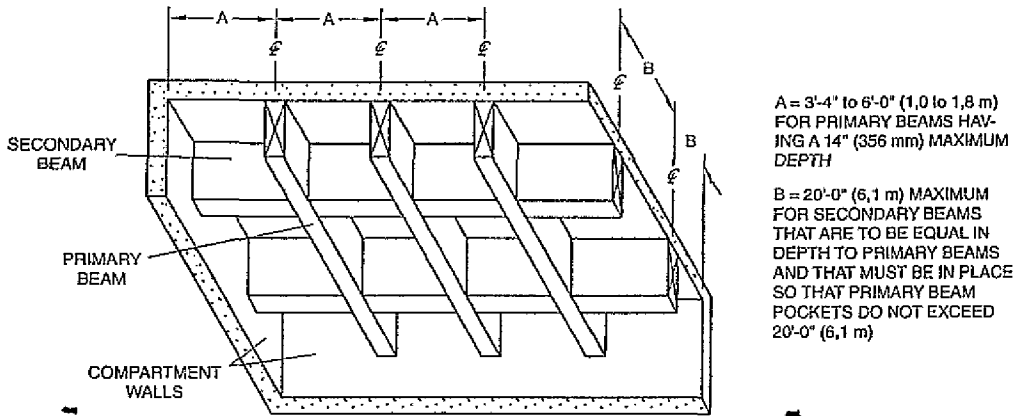
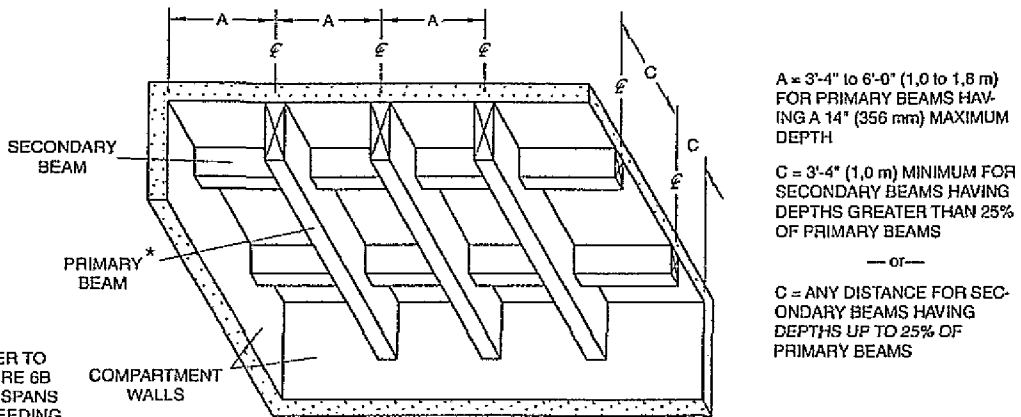

FIGURE 6B
PRIMARY BEAM SPANS GREATER THAN 20'-0" (6,1 m)



* REFER TO
FIGURE 6B
FOR SPANS
EXCEEDING
20'-0" (6,1 m)

FIGURE 6C
COMBINATIONS OF PRIMARY AND SECONDARY BEAMS

FIGURE 6
BEAM ARRANGEMENTS
(Refer to the "Beam Ceiling Design Criteria" section)

A = 3'-4" to 6'-0" (1,0 to 1,8 m)
FOR PRIMARY BEAMS HAV-
ING A 14" (356 mm) MAXIMUM
DEPTH

A = 3'-4" to 6'-0" (1,0 to 1,8 m)
FOR PRIMARY BEAMS HAV-
ING A 14" (356 mm) MAXIMUM
DEPTH

B = 20'-0" (6,1 m) MAXIMUM
FOR SECONDARY BEAMS
THAT ARE TO BE EQUAL IN
DEPTH TO PRIMARY BEAMS
AND THAT MUST BE IN PLACE
SO THAT PRIMARY BEAM
POCKETS DO NOT EXCEED
20'-0" (6,1 m)

A = 3'-4" to 6'-0" (1,0 to 1,8 m)
FOR PRIMARY BEAMS HAV-
ING A 14" (356 mm) MAXIMUM
DEPTH

C = 3'-4" (1,0 m) MINIMUM FOR
SECONDARY BEAMS HAVING
DEPTHS GREATER THAN 25%
OF PRIMARY BEAMS

— or —

C = ANY DISTANCE FOR SEC-
ONDARY BEAMS HAVING
DEPTHS UP TO 25% OF
PRIMARY BEAMS

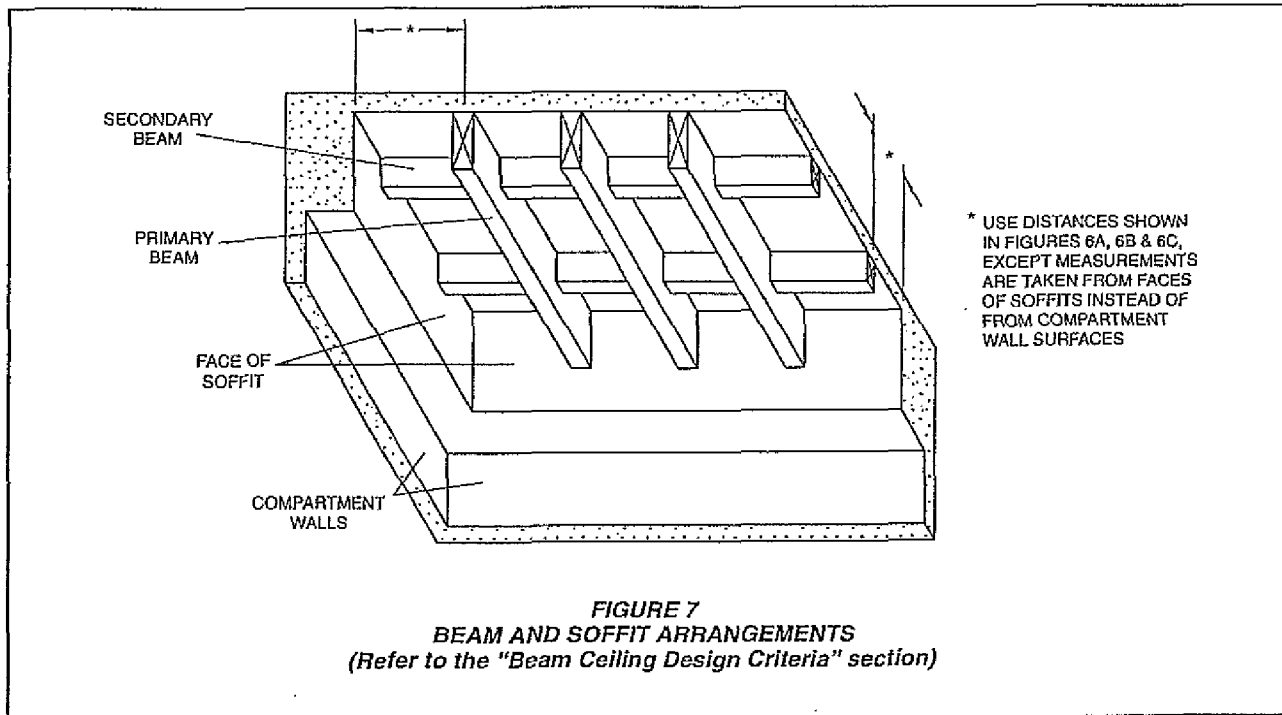

Installation

The Series LFII (TY2234) must be installed in accordance with the following instructions:

NOTES

Do not install any bulb type sprinkler if the bulb is cracked or there is a loss of liquid from the bulb. With the sprinkler held horizontally, a small air bubble should be present. The diameter of the air bubble is approximately 1/16 inch (1,6 mm).

A leak tight 1/2 inch NPT sprinkler joint should be obtained with a torque of 7 to 14 ft.lbs. (9,5 to 19,0 Nm). A maximum of 21 ft.lbs. (28,5 Nm) of torque is to be used to install sprinklers. Higher levels of torque may distort the sprinkler inlet with consequent leakage or impairment of the sprinkler.

Do not attempt to compensate for insufficient adjustment in an Escutcheon Plate by under- or over-tightening the Sprinkler. Readjust the position of the sprinkler fitting to suit.

The Series LFII Pendent Sprinklers must be installed in accordance with the following instructions.

Step 1. Pendent sprinklers are to be installed in the pendent position with the deflector parallel to the ceiling.

Step 2. With pipe thread sealant applied to the pipe threads, hand tighten the sprinkler into the sprinkler fitting.

Step 3. Tighten the sprinkler into the sprinkler fitting using only the W-Type 6 Sprinkler Wrench (Ref. Figure 3). With reference to Figure 1, the W-Type 6 Sprinkler Wrench is to be applied to the wrench flats.

The Series LFII Recessed Pendent Sprinklers must be installed in accordance with the following instructions.

Step A. Recessed pendent sprinklers are to be installed in the pendent position with the deflector parallel to the ceiling.

Step B. After installing the Style 20 Mounting Plate over the sprinkler threads and with pipe thread sealant applied to the pipe threads, hand tighten the sprinkler into the sprinkler fitting.

Step C. Tighten the sprinkler into the sprinkler fitting using only the W-Type 7 Recessed Sprinkler Wrench (Ref. Figure 4). With reference to Figure 1, the W-Type 7 Recessed Sprinkler Wrench is to be applied to the sprinkler wrench flats.

Step D. After the ceiling has been installed or the finish coat has been applied, slide on the Style 20 Closure over the Series LFII Sprinkler and push the Closure over the Mounting Plate until its flange comes in contact with the ceiling.

Care and Maintenance

The Series LFII (TY2234) must be maintained and serviced in accordance with the following instructions:

NOTES

Absence of an Escutcheon Plate may delay the sprinkler operation in a fire situation.

Before closing a fire protection system main control valve for maintenance work on the fire protection system which it controls, permission to shut down the affected fire protection system must be obtained from the proper authorities and all personnel who may be affected by this action must be notified.

Sprinklers which are found to be leaking or exhibiting visible signs of corrosion must be replaced.

Automatic sprinklers must never be painted, plated, coated, or otherwise altered after leaving the factory. Modified sprinklers must be replaced. Sprinklers that have been exposed to corrosive products of combustion, but have not operated, should be replaced if they cannot be completely cleaned by wiping the sprinkler with a cloth or by brushing it with a soft bristle brush.

Care must be exercised to avoid dam-

age to the sprinklers - before, during, and after installation. Sprinklers damaged by dropping, striking, wrench twist/slippage, or the like, must be replaced. Also, replace any sprinkler that has a cracked bulb or that has lost liquid from its bulb. (Ref. Installation Section).

The owner is responsible for the inspection, testing, and maintenance of their fire protection system and devices in compliance with this document, as well as with the applicable standards of the National Fire Protection Association (e.g., NFPA 25), in addition to the standards of any other authorities having jurisdiction. The installing contractor or sprinkler manufacturer should be contacted relative to any questions.

NOTE

The owner must assure that the sprinklers are not used for hanging of any objects and that the sprinklers are only cleaned by means of gently dusting with a feather duster; otherwise, non-operation in the event of a fire or inadvertent operation may result.

It is recommended that automatic sprinkler systems be inspected, tested, and maintained by a qualified Inspection Service in accordance with local requirements and/or national codes.

Limited Warranty

Products manufactured by Tyco Fire Products are warranted solely to the original Buyer for ten (10) years against defects in material and workmanship when paid for and properly installed and maintained under normal use and service. This warranty will expire ten (10) years from date of shipment by Tyco Fire Products. No warranty is given for products or components manufactured by companies not affiliated by ownership with Tyco Fire Products or for products and components which have been subject to misuse, improper installation, corrosion, or which have not been installed, maintained, modified or repaired in accordance with applicable Standards of the National Fire Protection Association, and/or the standards of any other Authorities Having Jurisdiction. Materials found by Tyco Fire Products to be defective shall be either repaired or replaced, at Tyco Fire Products' sole option. Tyco Fire Products neither assumes, nor authorizes any person to assume for it, any other obligation in connection with the sale of products or parts of products. Tyco Fire Products shall not be responsible for sprinkler system design errors or inaccurate or incomplete information supplied by Buyer or Buyer's representatives.

IN NO EVENT SHALL TYCO FIRE PRODUCTS BE LIABLE, IN CONTRACT, TORT, STRICT LIABILITY OR UNDER ANY OTHER LEGAL THEORY, FOR INCIDENTAL, INDIRECT, SPECIAL OR CONSEQUENTIAL DAMAGES, INCLUDING BUT NOT LIMITED TO LABOR CHARGES, REGARDLESS OF WHETHER TYCO FIRE PRODUCTS WAS INFORMED ABOUT THE POSSIBILITY OF SUCH DAMAGES, AND IN NO EVENT SHALL TYCO FIRE PRODUCTS' LIABILITY EXCEED AN AMOUNT EQUAL TO THE SALES PRICE.

THE FOREGOING WARRANTY IS MADE IN LIEU OF ANY AND ALL OTHER WARRANTIES EXPRESS OR IMPLIED INCLUDING WARRANTIES OF MERCHANTABILITY AND FITNESS FOR A PARTICULAR PURPOSE.

Ordering Procedure

When placing an order, indicate the full product name. Contact your local distributor for availability..

Sprinkler Assembly:

Series LFII (TY2234), K=4.9, Residential Pendent Sprinkler with (specify) temperature rating and (specify) finish, P/N (specify).

- 155°F/68°C or Chrome Plated P/N 51-201-9-155
- 155°F/68°C White Polyester P/N 51-201-4-155
- 155°F/68°C White (RAL9010)* P/N 51-201-3-155
- 155°F/68°C Natural Brass P/N 51-201-1-155
- 175°F/79°C or Chrome Plated P/N 51-201-9-175
- 175°F/79°C White Polyester P/N 51-201-4-175
- 175°F/79°C White (RAL9010)* P/N 51-201-3-175
- 175°F/79°C Natural Brass P/N 51-201-1-175

*Eastern Hemisphere sales only.

Recessed Escutcheon:

Specify: Style 20 Recessed Escutcheon with (specify) finish, P/N (specify).

- 1/2" (15 mm) Style 20 Chrome Plated P/N 56-705-9-010
- 1/2" (15 mm) Style 20 White Color Coated P/N 56-705-4-010
- 1/2" (15 mm) Style 20 White (RAL9010)* P/N 56-705-3-010
- 1/2" (15 mm) Style 20 Bright Brass Coated P/N 56-705-2-010

*Eastern Hemisphere sales only.

Sprinkler Wrench:

Specify: W-Type 6 Sprinkler Wrench, P/N 56-000-6-387.

Specify: W-Type 7 Sprinkler Wrench, P/N 56-850-4-001.



License Detail

CALIFORNIA CONTRACTORS STATE LICENSE BOARD

Contractor License # 561656

DISCLAIMER

A license status check provides information taken from the CSLB license data base. Before relying on this information, you should be aware of the following limitations:

- CSLB complaint disclosure is restricted by law (B&P 7124.6). If this entity is subject to public complaint disclosure, a link for complaint disclosure will appear below. Click on the link or button to obtain complaint and/or legal action information.
- Per B&P 7071.17, only construction related civil judgments known to the CSLB are disclosed.
- Arbitrations are not listed unless the contractor fails to comply with the terms of the arbitration.
- Due to workload, there may be relevant information that has not yet been entered onto the Board's license data base.

Extract Date: 10/22/2004

***** Business Information *****

RONALD L SCOGGINS DBA RLS FIRE PROTECTION SYSTEMS
 830 SHILOH ROAD BLDG 44 #E
 WINDSOR, CA 95492
 Business Phone Number: (707) 837-2045

RECEIVED
Scoggins

Entity: **Sole Ownership**

Issue Date: 03/23/1989 Expire Date: 02/28/2005

***** License Status *****

This license is current and active. All information below should be reviewed.

***** Classifications *****

| Class | Description |
|-------|----------------------------|
| C16 | FIRE PROTECTION CONTRACTOR |

***** Bonding Information *****

CONTRACTOR'S BOND: This license filed Contractor's Bond number 6320018 in the

amount of \$10,000 with the bonding company
SURETY COMPANY OF THE PACIFIC.
Effective Date: 01/01/2004

Contractor's Bonding History

***** Workers Compensation Information *****

This license has workers compensation insurance with the
STATE COMPENSATION INSURANCE FUND
Policy Number: 1674403 Effective Date: 02/08/2002 Expire Date: 02/08/2005

Workers Compensation History

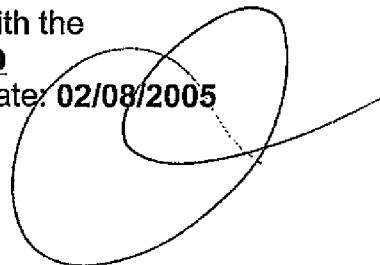

Personnel List

License Number Request

Contractor Name Request

Personnel Name Request

Salesperson Request

Salesperson Name Request

© 2004 State of California. Conditions of Use Privacy Policy

RETAI
6/2/04