

B

Type

37

Docs

0

Plans

BLD04-6377

Building Permit Number (List all associated with these documents)

921

Street Number

Sebastopol Rd.

Street Name

ROS

Community Code

125-101-047

APN

COUNTY OF SONOMA
PERMIT AND RESOURCE MANAGEMENT DEPARTMENT

2550 VENTURA AVENUE, SANTA ROSA, CA 95403-2829
 (707) 565-1900 FAX (707) 565-1103

Building Permit Invoice: BLD04-6377

Project Address: 921 SEBASTOPOL RD ROS
Cross Street: DUTTON AVE
APN: 125-101-047

Status: **PREISSUE**
Printed: October 27, 2004
Initialized by: LHELTON
Activity Type: B-BLD 401

Description: COMMERCIAL PHOTOVOLTAICE TO STORE ROOF & PUMP

Res/Com: C **Insp Area:** 10
Std/Quick: Q **Site Review File #:**
Fire District: ROSELAND FIRE GENERAL (S.R.) **Site Review Fees Paid:** \$0.00

Owner: BRESLER PHILLIP M
 10012 ALEGRIA DR
 LAS VEGAS NV 89134

Applicant: PACIFIC POWER MANAGEMENT
 12970 EARHART AVE STE 110
 AUBURN CA 95602
 530 887 1984

Valuation:

Occupancy	Type	Factor	Sq Feet	Valuation
	Totals...			\$0.00*

Fees:

Item#	Description	Account Code	Tot Fee	Prev. Pmts	Cur. Pmts
60	BLDG PERM PLAN CHECK FEE	025015-1341	102.00	.00	.00
122	ELECTRICAL FEE	025015-1341	267.50	.00	.00
140	TECH ENHANCEMENT FEE	025015-4040	1.93	.00	.00
1165	ZONING PERMITS W/O D.R.	025015-3829	75.00	.00	.00
			\$446.43	\$0.00	

Total Fees: \$446.43

Total Paid: \$0.00

Balance Due: \$446.43

Refunds are regulated by the California Building Code (CBC) which reads: "Under Section 107.6, CBC, the building official may authorize refunding of not more than 80 percent of the plan review fee paid when an application is withdrawn or canceled before any plan reviewing is done. The building official may authorize refunding of not more than 80 percent of the permit fee paid when no work has been done under the permit. There shall be no refunding of any fee paid except on written application filed by the original permittee not later than 180 days after the date of fee payment."

When validated below, this is your receipt.
 This Building Permit shall EXPIRE

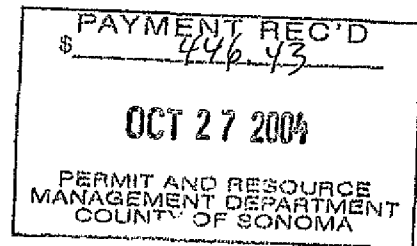

COUNTY OF SONOMA - PERMIT AND RESOURCE MANAGEMENT DEPARTMENT

2550 Ventura Avenue, Santa Rosa, CA 95403 (707) 565-1900 FAX (707) 565-1103

Please Print Your Name: **RICHARD GLEASON** Date Applied: **10/27/04**

INFORMATION WITHIN HEAVY LINE TO BE COMPLETED BY APPLICANT

SITE LOCATION INFORMATION - PRINT CLEARLY

Site Address: **921 SEBASTOPOL RD.** City: **SANTA ROSA CA.** ZIP: _____
 Cross Street: **DUTTON AVE.** APN: **125-101-047** Project Phone #: () Project Fax #: ()
 Directions: _____ Subd. Name: _____ Unit #: _____ Lot #: _____
 Describe Project: **ADD PHOTOVOLTAIC SYSTEM TO STORE ROOF & PUMP CANOPY** Living Area: _____ Garage: _____ Decks: _____ Contract Price: **\$18,240**

OWNER NAME AND ADDRESS **APPLICANT NAME AND ADDRESS**

Name: **NGWA OIL COMPANY P. BYES** Name: **RIKH GLEASON**
 Mailing Address: **2349 RICKEN BACKER WAY** Mailing Address: **12970 EARHART AVE. STE. 110**
 City: **AUBURN** State: **CA.** ZIP: **95602** City: **AUBURN** State: **CA.** ZIP: **95602**
 Day Ph: **(530) 885-0401** Fax: () Day Ph: **916 835-0094** Fax: **(530) 887-1986**

CONTRACTOR INFORMATION **OTHER PERSONS (ARCHITECT, ENGINEER, ETC.)**

Company Name: **PACIFIC POWER MANAGEMENT** Name: **CRAIG ROWLAND P.E.**
 Address: **12970 EARHART AVE. STE. 110** Address: **17924 LAKE ARTHUR RD.**
 City: **AUBURN** State: **CA.** ZIP: **95602** City: **APPLEGATE** State: **CA** ZIP: **95703**
 Day Ph: **530 887-1984** Fax: **530 887-1986** Day Ph: **530 878-9990** Fax: ()

License No: **C039886** Exp. Date: **12-05**

WORKER'S COMPENSATION DECLARATION

I hereby affirm under penalty of perjury one of the following declarations:
 I have and will maintain a certificate of consent to self-insure for worker's compensation, as provided for by Section 3700 of the Labor Code, for the performance of the work for which this permit is issued.
 I have and will maintain worker's compensation insurance, as required by Section 3700 of the Labor Code, for the performance of the work for which this permit is issued. My worker's compensation insurance carrier and policy number are:
 Carrier: **STATE FUND**
 Policy No.: **1708661-04**
 (This section need not be completed if the permit is for one hundred dollars (\$100) or less.)
 I certify that in the performance of the work for which this permit is issued, I shall not employ any person in any manner so as to become subject to the worker's compensation laws of California, and agree that if I should become subject to the worker's compensation provisions of Section 3700 of the Labor Code, I shall forthwith comply with those provisions.
 Exp. Date: **5-1-05** Applicant: *[Signature]*

WARNING: FAILURE TO SECURE WORKER'S COMPENSATION COVERAGE IS UNLAWFUL, AND SHALL SUBJECT AN EMPLOYER TO CRIMINAL PENALTIES AND CIVIL FINES UP TO ONE HUNDRED THOUSAND DOLLARS (\$100,000), IN ADDITION TO THE COST OF COMPENSATION, DAMAGES AS PROVIDED FOR IN SECTION 3706 OF THE LABOR CODE, INTEREST AND ATTORNEY'S FEES.

OWNER-BUILDER DECLARATION

I hereby affirm under penalty of perjury that I am exempt from the Contractor's License Law for the following reason (Sec. 7031.5, Business and Professions Code: Any city or county which requires a permit to construct, alter, improve, demolish, or repair any structure, prior to its issuance, also requires the applicant for such permit to file a signed statement that he or she is licensed pursuant to the provisions of the Contractor's License Law (Chapter 9 (commencing with Section 7000) of Division 3 of the Business and Professions Code) or that he or she is exempt therefrom and the basis for the alleged exemption. Any violation of Section 7031.5 by any applicant for a permit subjects the applicant to a civil penalty of not more than five hundred dollars (\$500).):
 I, as owner of the property, or my employees with wages as their sole compensation, will do the work, and the structure is not intended or offered for sale (Sec. 7044 Business and Professions Code: The Contractors License Law does not apply to an owner of property who builds or improves thereon, and who does such work himself or herself or through his or her own employees, provided that such improvements are not intended or offered for sale. If, however, the building or improvement is sold within one year of completion, the owner-builder will have the burden of proving that he or she did not build or improve for the purpose of sale.)
 I, as owner of the property, am exclusively contracting with licensed contractors to construct the project (Sec. 7044, Business and Professions Code: The Contractors License Law does not apply to an owner of property who builds or improves thereon, and who contracts for such projects with a contractor(s) licensed pursuant to the Contractors License Law.)
 I am exempt under Sec. _____, B & P.C. for this reason _____
 Date: _____ Owner: _____

LICENSED CONTRACTOR'S DECLARATION

I hereby affirm under penalty of perjury that I am licensed under provisions of Chapter 9 (commencing with Section 7000) of Division 3 of the Business and Professions Code, and my license is in full force and effect.
 Lic. Class: **B** Lic. No.: **840482**
 Exp. Date: **6/1/06** Contractor: *[Signature]*

ASBESTOS DECLARATION

Written asbestos notification pursuant to Part 61 of Title 40 of the Code of Federal Regulations is required when asbestos exists in buildings, or portions thereof, undergoing demolition. I hereby declare that demolition authorized by this permit is from construction that () does () does not contain asbestos, or that () no demolition is authorized by this permit.

I certify that I have read this application and affirm under penalty of perjury that the above information is correct. I agree to comply with all local Ordinances and State laws relating to building construction. I hereby authorize representatives of the County of Sonoma to enter upon the above-mentioned property for inspection purposes. If, after making the Certificate of Exemption for the Worker's Compensation provision of the Labor Code I should become subject to such provisions, I will forthwith comply. In the event I do not comply with the Workman's Compensation law, this permit shall be deemed revoked.
[Signature]

PERMITTEE SIGNATURE: _____
 ADDRESS: **12970 EARHART AVE. STE. 110 AUBURN CA 95602**
 Contractor Owner Other Licensed Professional

Final Date: _____ Inspector: _____

CONSTRUCTION LENDING DECLARATION

I hereby affirm under penalty of perjury that there is a construction lending agency for the performance of the work for which this permit is issued. (Sec. 3097, Ch.C.)
 Lenders Name: _____
 Lenders Address: _____

FOR DEPARTMENT USE

Zoning: **C2** File No. _____ Acres: **4.42**
 Existing Use/Structures: **garage**
 Proposed Use/Structures: **add solar panels on roof**
 Zoning Min. Yard Requirements: _____
 NOTE: Fire Safe Standards require all parcels greater than 1 Acre to have min. 30' setback unless mitigated. Mitigation Required Address subject to change
 Approval for Permit Issuance: _____ Approval for Occupancy: _____
 By: _____ Date: **10-27-04**

Conditions: **Approved for roof mounted solar panels or existing gas station canopy + utility lines**

Sewer Connection: Available Fees Paid
 Approved by: _____ Date: _____

Road Encroachment: Fees Paid
 Approved by: _____ Date: _____

Septic System Permit/Clearance # _____
 Approved by: _____ Date: _____

Flood Zone: Yes No 100 Year Flood Elevation: _____
 Site Review: _____
 Drainage Review: _____
 Approved by: _____ Date: _____

Fire: _____
 Approved by: _____ Date: _____

Code Enforcement Violation Yes No Violation # _____
 This permit is limited to _____ days.

Work Authorized: **TV system @ store; canopy roof**

Plans Approved Post FIRI Airtight Photo Report Available
 No Plans Submitted for Field Inspection Pre FIRI Geotechnical report Available
 Plancheck Closed By: *[Signature]* Date: **10/27/04** Type of Construction: **YN** Occupancy: **B** No. of Stories: _____ No. of Bedrooms: _____
 Permit Closed for Issuance By: *[Signature]* Date: **10/27/04** Acts, Fire Sprinklers Req'd: _____ No. of Units: _____ Certificate of Occupancy: _____

Machine Stamps for Permit Fee: **2476.93**
OCT 27 2004
 PERMIT AND RESOURCE MANAGEMENT DEPARTMENT
 COUNTY OF SONOMA

JOB ADDRESS: **921 Sebastopol Rd, ROSA**
 PERMIT NUMBER: **BA004-0377**
 INSPECTION AREA: **10**

131)	SPECIAL INSPECTION REQUIRED	DATE	YES	NO	IF YES, SEE ADDITIONAL SHEET
	INSPECTION RECORD		NAME		REMARKS
101)	ROUGH GRADING				
103)	FOUNDATION				
	FORMS/SETBACK				
	FOOTING				
	WALLS				
106)	UFER GROUND #				
104)	CAISSONS/PIERS				
105)	SLAB				
107)	UNDERGROUND UTILITIES				
110)	MASONRY				
109)	RETAINING WALLS				
113)	FIREPLACE				
	FOOTING				
	HEARTH/PROTECTION				
	THROAT				
114)	CHIMNEY				
120)	UNDERFLOOR/UNDERSLAB				
115)	HYDRONICS				
116)	U/F ELECTRICAL				
117)	U/F MECHANICAL				
118)	U/F PLUMBING				
119)	U/F FRAMING				
139)	U/F INSULATION				
126)	SHEAR WALLS				
	<input type="checkbox"/> INTERIOR		<input type="checkbox"/> EXTERIOR		
127)	DIAPHRAGMS				
	<input type="checkbox"/> ROOF		<input type="checkbox"/> FLOOR		
134)	SIDING/SHEATHING				
125)	HOLD DOWNS				
132)	CLOSE-IN				
122)	ROUGH ELECTRICAL	5/6/05			NO PLANS OR DEFINITION ACCESSY GMS 4/20/05
123)	ROUGH MECHANICAL				
124)	ROUGH PLUMBING				
128)	ROUGH FRAME				
160)	SMOKE DETECTORS				
139)	INSULATION				
142)	WALLBOARD				
143)	FIREWALLS				
135)	STUCCO/PLASTER				
	<input type="checkbox"/> LATH		<input type="checkbox"/> SCRATCH		
137)	ROOFING				
130)	TUB/SHOWER PAN				
162)	FIRE DAMPERS/DOORS				* 174 TO facilitate PGE Shut Down & Re Energized
164)	SUSPENDED CEILING				
	<input type="checkbox"/> ROUGH ELEC.		<input type="checkbox"/> ROUGH MECH.		
165)	EXITING - RAMPS/STAIRS				
163)	HANDRAILS/GUARDRAILS				
	CORRIDORS/DOORS				
166)	ACCESSIBILITY COMPLIANCE				650) SUSMP INSPECTION
144)	WATER TANKS				651) NPDES EROSION COMPLIANCE
	<input type="checkbox"/> SLAB		<input type="checkbox"/> WALLS		652) NPDES SEDIMENT COMPLIANCE
170)	TEMPORARY OCCUPANCY				653) NPDES DOCS/SWPPP
171)	TEMPORARY ELECTRICAL	5/6/05			FIRE INSPECTION REQUIRED
172)	TEMPORARY GAS				<input type="checkbox"/> Yes <input type="checkbox"/> No
174)	ELECTRIC METER AUTHORIZATION	5/6/05			759) KNOX BOX
152)	PANEL BOARDS/SERVICE				760) PROPANE TANK HOLD DOWNS
189)	SEPTIC ELECTRIC FINAL				770) SPRINKLER FINAL
175)	GAS METER AUTHORIZATION				771) ABOVEGROUND HYDROSTATIC
153)	GAS PRESSURE TEST				772) UNDERGROUND HYDROSTATIC
	HOUSE				773) UNDERGROUND FLUSH
	YARD				774) THRUST BLOCKS
190)	MANUF. HOME FOUNDATION				775) PIPE WELD
191)	MANUF. HOME INSTALLATION				776) HYDRANTS/APPLIANCES
	CONTINUITY				777) PUMP ACCEPTANCE
	STAIRS/SKIRTS				778) WATER SUPPLY/TANK
	RIDGE BOLTING				779) ALARM SYSTEM
193)	MANUF. HOME COND. FINAL				780) HOOD & DUCT SYSTEM
	SWIMMING POOLS				781) ABOVEGROUND TANK/DISPENSER
194)	PRE-GUNITE				198) FIRE FINAL
195)	PRE-DECK				
196)	PRE-PLASTER/FENCE				
197)	VINYL/FIBERGLASS POOL EXCAVATION				CLEARANCES:
102)	GRADING FINAL				FIRE <input type="checkbox"/> Local <input type="checkbox"/> County
176)	ELECTRICAL FINAL	8/15/05			HEALTH DEPARTMENT
177)	MECHANICAL FINAL				ZONING
178)	PLUMBING FINAL				SANITATION
199)	FINAL	8/15/05			
	OCCUPANCY (OK TO OCCUPY)				PLAN RETENTION REQUIRED?
					<input type="checkbox"/> Yes <input type="checkbox"/> No

PERMIT # BLD04-6317

JOB: Nella Oil # 279

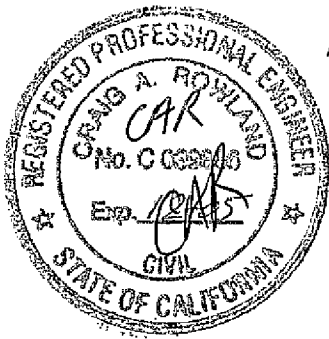

12/12 PAGES
20 OCT 04

1/12

Craig A. Rowland, P.E.
17924 Lake Arthur Road
Applegate, CA 95703
(530) 878-9990
FAX (530) 878-4552

Load Determination

Roof Live Load	20.0 psf
Ceiling Live Load	- psf
Floor Live Load	- psf
Deck Live Load	- psf

Roof Dead Load	
PV unit	2.68 psf
Uni Strut B22	0.4 psf
Rafters / Trusses	- psf
Insulation	- psf
1/2 gypsum	- psf
Misc.	- psf
Dead load	3.03 psf
Live load	20.0 psf
Total Load	23.0 psf

Ceiling Dead Load	
Insulation	- psf
1/2 gypsum	- psf
Joists	- psf
Misc.	- psf
Dead load	- psf
Live load	- psf
Total Load	- psf

Total Roof / Ceil System 23.0 psf

Floor Dead Load	
Insulation	- psf
3/4 ply	- psf
Joist	- psf
1/2 gypsum	- psf
Misc.	- psf
Dead load	- psf
Live load	- psf
Total Load	- psf

Deck Dead Load	
2 x decking	- psf
Joist	- psf
Misc.	- psf
Dead load	- psf
Live load	- psf
Total Load	- psf

All Table Values in psf

Trusses	12" OC	16" OC	24" OC
2 x 4	6.0	4.0	3
2 x 6	9.0	6.0	4.5
2 x 8	12.0	8.0	6

0.166667

Framing	12" OC	16" OC	24" OC
2x4	1.3	1.0	0.7
2x6	2.1	1.6	1.0
2x8	2.7	2.1	1.4
2x10	3.5	2.6	1.7
2x12	4.3	3.2	2.1

Decking	2"	3"	4"
DF	4.5	7.6	10.6
Pine	3.7	6.2	8.6
Redwood	3.3	5.5	7.7
Cedar	3.3	5.5	7.7

Gypsum	
1/2	2.0 psf
5/8	2.5 psf

Insulation	
R11	0.3 psf
R19	0.5 psf
R30	0.8 psf
R38	1.0 psf

Ply	
3/8	1.3 psf
1/2	1.8 psf
5/8	2.2 psf
3/4	2.6 psf
1 1/8	3.9 psf
1 1/4	4.4 psf

Plaster	9 psf
Concrete	50 psf
Foam Ins.	0.3 psf
1" Hard Wd.	4.5 psf
Windows	10 psf

2/12

JOB:	Nella Oil		Roof Load		WALL		WALL		psf		FLOOR		FLOOR		Deck Load		DECK	
BEAM	SPAN	UNIFORM	ROOF	ft	ft	ft	ft	ft	ft	psf	psf	psf	psf	psf	psf	psf	psf	psf
A	5.5	119	119	5.2	0	0	0	0	0	0	0	0	0	0	0	0	0	0
B	11.33	123	123	5.33	0	0	0	0	0	0	0	0	0	0	0	0	0	0
C	11.33	62	62	2.7	0	0	0	0	0	0	0	0	0	0	0	0	0	0

23

4/12

20 PSF L. LOAD

JOB: Nella Oil

CANTILVEVER STEEL BEAM

BEAM	SPAN LOAD		REACTIONS		MOMENT		STEEL		I	S	A _w	MOD. E	F _b	f _b	DEFLECTION			
	L	w	R ₁	R ₂	M _{CANT}	M	S REQD	F _y							SIZE	Δ	Δ _{ALLOW}	
	feet	plf	lbs	lbs	in-lbs	in-lbs	in ³	ksi	in	in	si	psi	psi	in	in			
A	5.5	119	260	692	4,463	3,399	0.205	33.0	B12	0.5203	0.3927	0.7270	2.9E+07	21780	11364	0.37	0.03	180

5/12

B22 CHANNEL

Channel Combinations & Hole Patterns

Channel Nuts & Hardware

Fittings

Beam Clamps

Pipe Clamps

Electrical Accessories

Special Materials & Fiberglass

Mini Channel & Fittings

Concrete Inserts

Slotted Angle

Reference Data/Index

B22

- Thickness: 12 Gauge (2.6 mm)
- Standard lengths: 10' (3.05 m) & 20' (6.09 m)
- Standard finishes: Plain, Dura-Green, Pre-Galvanized, Hot-Dipped Galvanized, Stainless Steel Type 304 or 316, Aluminum
- Weight: 1.90 Lbs./Ft. (2.83 kg/m)

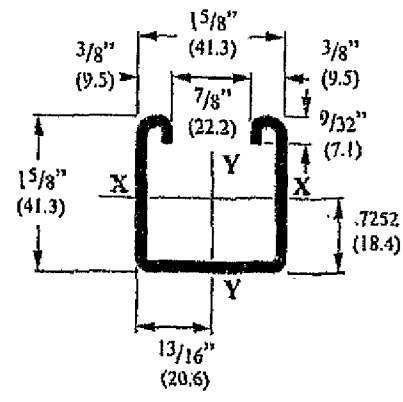
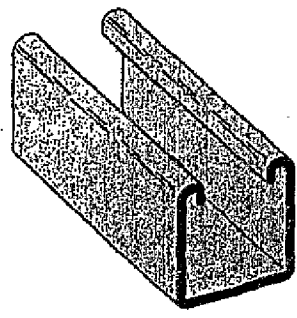

SECTION PROPERTIES

Channel	Weight lbs./ft. kg/m	Areas of Section		Moment of Inertia (I)		Section Modulus (S)		Radius of Gyration (r)		Moment of Inertia (I)		Section Modulus (S)		Radius of Gyration (r)	
		sq. in.	cm ²	in. ⁴	cm ⁴	in. ³	cm ³	in.	cm	in. ⁴	cm ⁴	in. ³	cm ³	in.	cm
B22	1.910 (2.84)	.562 (3.62)	.1912 (7.96)	.2125 (3.48)	.583 (1.48)	.2399 (9.99)	.2953 (4.84)	.653 (1.66)							
B22A	3.820 (5.69)	1.124 (7.25)	.9732 (40.51)	.5989 (9.81)	.931 (2.36)	.4798 (19.97)	.5905 (9.68)	.653 (1.66)							
B22X	6.649 (9.89)	1.956 (12.62)	4.1484 (172.67)	1.7019 (27.89)	1.456 (3.70)	1.1023 (45.88)	1.2027 (19.71)	.751 (1.91)							

Calculations of section properties are based on metal thicknesses as determined by the AISI Cold-Formed Steel Design Manual.

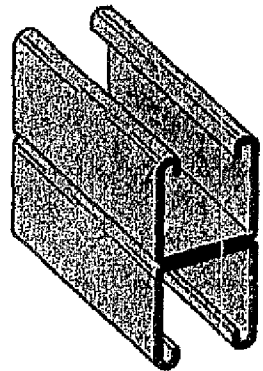

B22A
Wt. 3.80 Lbs./Ft. (5.65 kg/m)

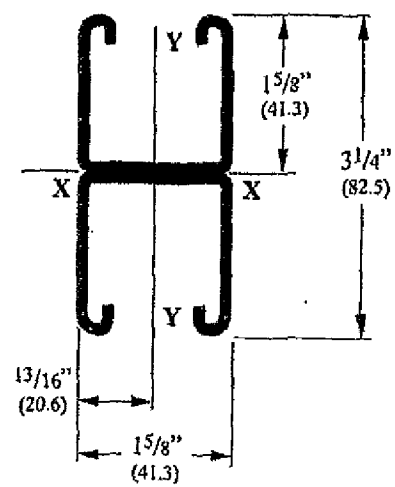

Physical and Dimensional Specifications - Stainless **BOLTS**

6/12

	Dimensional	Physical
<p>8-2-304-316 hex head cap screws</p>	<p>Head and body dimensions to ANSI B18.2.1</p> <p>Thread dimensions to class 2A fit, ANSI B1.1</p> <p>Thread length to ANSI B18.2.1 minimum - actual thread length may be longer. See chart in catalog</p>	<p>Cold formed hex caps - tensile, yield and hardness increase sharply during cold-formed manufacturing of stainless. Figures below are approximate and are often much higher than shown.</p> <p>Tensile - 100,000-125,000 psi Yield - 55,000-75,000 psi Hardness - 100 Rockwell B Elongation - 30% Reduction in area - 40% Magnetic permeability - 2.0 max.</p> <p>Hot-forged hex caps - Tensile - 70,000 psi min. Yield - 30,000 psi min. Hardness - 70 Rockwell B min. Elongation - 30% min. Reduction in area - 40% min. Magnetic permeability - 2.0 max.</p>
<p>18-8-316 finished hex nut jam heavy heavy large machine screw small pattern nylon insert cap wing</p>	<p>Finished, jam, heavy, heavy jam - thickness and width across flats to ANSI B18.2.2</p> <p>Thread dimensions to class 2B, ANSI B1.1</p>	<p>All cold-formed nuts - tensile, yield and hardness increase sharply during cold-formed manufacturing of stainless. Figures below are approximate and are often much higher than shown.</p> <p>Tensile - 100,000-125,000 psi Yield - 55,000-75,000 psi Hardness - 100 Rockwell B Elongation - 30% Reduction in area - 40% Magnetic permeability - 2.0 max.</p>
	<p>Machine screw nuts - thickness and width across flats to ANSI B18.6.3</p> <p>Thread dimensions to class 2B, ANSI B1.1</p>	<p>All hot-forged nuts - Tensile - 70,000 psi Yield - 30,000 psi Hardness - 70 Rockwell B min. Reduction in Area - 40% Magnetic permeability - 2.0 max.</p>
	<p>Nylon insert, small pattern, cap, wing - thread dimensions to class 2B, ANSI B1.1</p> <p>Thickness, width across flats and other dimensions - see chart in catalog</p>	<p>Nylon insert - normally nylon 66 with resisting temperature of 268 degrees F., heat distortion at 360 degrees F. and melt-down at 480 degrees F. Nylon tensile increases with temperature decrease and is not affected by cold.</p>
<p>18-8-316 socket cap socket set lat socket nut socket square head sets slotted headless sets</p>	<p>Socket caps, sets, flats, buttons - head, body and socket dimensions to ANSI B18.3</p> <p>Thread dimensions to class 3A fit, ANSI B1.1</p> <p>Thread lengths: see chart in catalog</p> <p>Socket caps normally knurled heads except #2 dia. & below.</p>	<p>Cold-formed - tensile, yield and hardness increase sharply during cold-formed manufacturing of stainless. Figures below are approximate and are often much higher than shown.</p> <p>Tensile - 100,000-125,000 psi Yield - 55,000-75,000 psi Hardness - 100 Rockwell B Elongation - 30% Reduction in area - 40% Magnetic permeability - 2.0 max.</p>
	<p>Square set, slotted headless sets - head and body dimensions to ANSI B18.6.2</p> <p>Thread dimensions to class 2A, ANSI B1.1</p>	
<p>18-8-316 machine screw sheet metal screws wood screws</p>	<p>Machine screws - head, body, slot and recess dimensions to ANSI B18.6.3</p> <p>Thread dimensions to class 2A fit, ANSI B1.1</p> <p>Thread length: see chart in catalog</p> <p>Sheet metal screws - head, slot and recess dimensions to ANSI B18.6.4.</p> <p>Stainless sheet metal screws are normally type A or type B, not type AB.</p> <p>Thread dimensions: see chart in catalog</p> <p>Wood screws - Head, body, slot, recess and thread dimensions to ANSI B18.6.1</p> <p>Thread length: see chart in catalog</p>	<p>Tensile, yield and hardness increase sharply during cold-formed manufacturing of stainless. Figures below are approximate and are often much higher than shown.</p> <p>Tensile - 100,000-125,000 psi Yield - 55,000-75,000 psi Hardness - 100 Rockwell B Elongation - 30% Reduction in area - 40% Magnetic permeability - 2.0 max.</p>

BOLT TO BE USED

NUTS FOR B22, B24, B26, B32 CHANNELS

Part Number			Thread Size	Thickness		Weight Per 100	
With Spring	Without Spring	Twirl Nut				Lbs.	kg
N221	N221WO	TN221	#8-32	1/4"	(6.3)	7.0	(3.17)
N222	N222WO	TN222	#10-24	1/4"	(6.3)	7.0	(3.17)
N227	N227WO	TN227	#10-32	1/4"	(6.3)	7.0	(3.17)
N224	N224WO	TN224	1/4-20	1/4"	(6.3)	6.7	(3.04)
N223	N223WO	TN223	5/16-18	1/4"	(6.3)	6.7	(3.04)
N228	N228WO	<u>TN228</u>	3/8-16	3/8"	(9.5)	9.3	(4.22)
N226	N226WO	TN226	7/16-14	3/8"	(9.5)	8.8	(3.99)
N225	N225WO	TN225	1/2-13	1/2"	(12.7)	11.6	(5.26)
N255	N255WO	-	3/8-11	1/2"	(12.7)	16.4	(7.44)
N275	N275WO	-	3/4-10	1/2"	(12.7)	14.5	(6.58)
N278	N278WO	-	7/8-9	1/2"	(12.7)	12.5	(5.67)

STANDARD FINISH: Electro-Plated

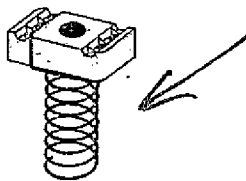

SPRING NUT

MATCH THREAD DIMENSIONS TO BOLT USED



NUT WITHOUT SPRING

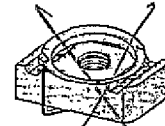

TWIRL-NUT®

Patented

STUD NUTS FOR B22, B24, B26, B32 CHANNELS

Part Number			Thread Size	Thickness		Stud Length		Weight Per 100	
With Spring	Without Spring	Twirl Nut						Lbs.	kg
SN224-3/4	SN224-3/4WO	STN224-3/4	1/4-20	1/4"	(6.3)	3/4	(19.0)	7.7	(3.49)
SN224-1	SN224-1WO	STN224-1				1	(25.4)	8.0	(3.63)
SN224-1 1/4	SN224-1 1/4WO	STN224-1 1/4				1 1/4	(31.7)	8.2	(3.72)
SN224-1 1/2	SN224-1 1/2WO	STN224-1 1/2				1 1/2	(38.1)	8.4	(3.81)
SN228-3/4	SN228-3/4WO	STN228-3/4	3/8-16	3/8"	(9.5)	3/4	(19.0)	12.0	(5.44)
SN228-1	SN228-1WO	STN228-1				1	(25.4)	12.6	(5.71)
SN228-1 1/4	SN228-1 1/4WO	STN228-1 1/4				1 1/4	(31.7)	13.2	(5.99)
SN228-1 1/2	SN228-1 1/2WO	STN228-1 1/2				1 1/2	(38.1)	13.8	(6.26)
SN225-3/4	SN225-3/4WO	STN225-3/4	1/2-13	1/2"	(12.7)	3/4	(19.0)	16.5	(7.48)
SN225-1	SN225-1WO	STN225-1				1	(25.4)	17.6	(7.98)
SN225-1 1/4	SN225-1 1/4WO	STN225-1 1/4				1 1/4	(31.7)	18.7	(8.48)
SN225-1 1/2	SN225-1 1/2WO	STN225-1 1/2				1 1/2	(38.1)	19.8	(8.98)

STANDARD FINISH: Electro-Plated

Other stud lengths available

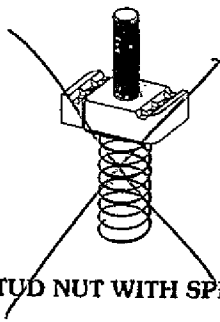

STUD NUT WITH SPRING

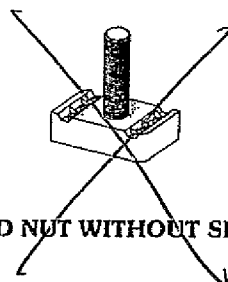

STUD NUT WITHOUT SPRING

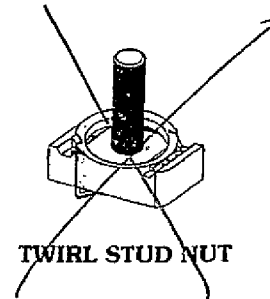

TWIRL STUD NUT



8/12

Recommended Bolted Metal Framing Specification

MATERIAL SPECIFICATION

The bolted metal framing system shall be made of channel, fittings, and hardware as defined in the Metal Framing Manufacturers Association Standard Publication MFMA-1.

MATERIAL AND FINISHES

Aluminum

Aluminum channel and closure strips shall be extruded from Aluminum Association Alloy 6063-T6. Fabricated parts shall be made from Alloy 5052-H32.

Pre-Galvanized Steel

Pre-galvanized channel shall be made from steel in accordance with ASTM A446, Grade A and mill-galvanized in accordance with ASTM A525, Coating Designation G90.

Hot-Dip Galvanized After Fabrication Steel

Channels Hot-Dip Galvanized After Fabrication shall be made from steel meeting the minimum requirements of ASTM A570, Grade 33. Eighteen gauge (1.2 mm) and lighter channel shall be ASTM A611, Grade C steel. Channels shall be Hot-Dip Galvanized After Fabrication in accordance with ASTM A123. All 1/4" (6.3) fittings shall be formed from ASTM A635 steel and Hot-Dip Galvanized After Fabrication in accordance with ASTM A123.

Stainless Steel

Stainless Steel Channel and accessories shall be of AISI Type 304 or Type 316 Stainless Steel.

Green Epoxy

Painted channel shall meet the minimum mechanical properties of ASTM A570 Grade 33 steel and painted with electrodeposited, epoxy

base dark green paint. All 1/4" (6.3) accessories shall be produced from ASTM A635 steel and painted with electrodeposited, epoxy base dark green paint.

Electro-Plated Zinc.

Electro-Plated Zinc finish on fittings and hardware shall be plated after fabrication in accordance with ASTM B633, SC3 or SC1 respectively.

Dimensions







Metal Framing Channel shall be cold formed from 12 Ga. (2.6), 14 Ga. (1.9), or 16 Ga. (1.5) steel. All channels shall have a nominal overall width of 1 5/8" (41.3) and have a 7/8" (22.2) slot face opening. Standard lengths are to be 10 (3.05m) and 20 (6.09m) foot. All testing and tolerancing shall be in accordance with the latest MFMA-1 Standard.

CHANNEL



9/12

SELECTION CHART for Channels, Materials and Hole Patterns

Channel Type	Channel Dimensions		Material & Thickness *				Channel Hole Pattern **				
	Height 	Width 	Steel 1	Alum. 2	Stainless Steel		SH 	S 	H1 7/8 	TH 	KO6 
					Type 304 3	Type 316 4					
B11	3 1/4" (82.5)	1 5/8" (41.3)	12 Ga.	--	--	--	1	1	1	--	1
B12	2 7/16" (61.9)	1 5/8" (41.3)	12 Ga.	.105	--	--	1 2	1	1 2	--	1 2
B22	1 5/8" (41.3)	1 5/8" (41.3)	12 Ga.	.105	12 Ga.	12 Ga.	1 2 3	1	1 2 3	1	1 2
B24	1 5/8" (41.3)	1 5/8" (41.3)	14 Ga.	.080	14 Ga.	14 Ga.	1 2 3 4	1	1 2 3 4	--	1 2
B26	1 5/8" (41.3)	1 5/8" (41.3)	16 Ga.	--	--	--	1	1	1	--	1
B32	1 3/8" (34.9)	1 5/8" (41.3)	12 Ga.	--	12 Ga.	--	1 3	1	1 3	--	1
B42	1" (25.4)	1 5/8" (41.3)	12 Ga.	--	12 Ga.	--	1 3	1	1 3	--	1
B52	13/16" (20.6)	1 5/8" (41.3)	12 Ga.	--	12 Ga.	--	1 3	1	1 3	--	1
B54	13/16" (20.6)	1 5/8" (41.3)	14 Ga.	.080	14 Ga.	14 Ga.	1 2 3 4	1	1 2 3 4	--	1 2
B56	13/16" (20.6)	1 5/8" (41.3)	16 Ga.	--	--	--	1	1	1	--	1
B62	13/16" (20.6)	13/16" (20.6)	18 Ga.	--	--	--	--	--	--	--	--
B72	13/32" (10.3)	13/16" (20.6)	18 Ga.	--	--	--	--	--	--	--	--
E7016	3/4" (19.0)	5/8" (15.9)	16 Ga.	--	--	--	--	--	--	--	--

The selection has been prepared to provide a reference for available channel, materials and hole patterns. Material types available for various hole patterns are defined by numbers 1 thru 4.
Some stainless steel channels with hole patterns are available on special order only.

*Metric equivalent for thicknesses shown in chart.
12 Ga. = 2.6 mm 18 Ga. = 1.2 mm
14 Ga. = 1.9 mm .105 = 2.6 mm
16 Ga. = 1.5 mm .080 = 2.0 mm

** 1 - Steel
2 - Aluminum
3 - Type 304 Stainless Steel
4 - Type 316 Stainless Steel

Properties may vary due to commercial tolerances of the material.

B-LINE DURA-GREEN® EPOXY FINISH

Dura-Green is water borne epoxy resin paint permanently bonded to all metal surfaces by a cathodic electro-deposition process. There is no special ordering—it's standard.

This process deposits an organic epoxy finish on negatively charged metal parts immersed in tanks containing positively charged epoxy paint particles. There is total coverage, no excess buildup of paint, no flaking and no discoloration of the finish.



B22 BEAM LOADING DATA

10/12

Beam Span		Channel Style	Uniform Load and Deflection				Uniform Load @ Deflection =			
In.	mm		Lbs	N	In.	mm	L/240 Span		L/360 Span	
						Lbs	N	Lbs	N	
12	305	B22	3404	15142	.014	.35	3404	15142	3404	15142
		B22A	2610*	11610	.002	.05	2610*	11610	2610*	11610
		B22X	5790*	25755	.001	.02	5790*	25755	5790*	25755
18	457	B22	2269	10093	.031	.79	2269	10093	2269	10093
		B22A	2610*	11610	.007	.18	2610*	11610	2610*	11610
		B22X	5790*	25755	.003	.07	5790*	25755	5790*	25755
24	609	B22	1702	7571	.056	1.42	1702	7571	1702	7571
		B22A	2610*	11610	.017	.43	2610*	11610	2610*	11610
		B22X	5790*	25755	.008	.20	5790*	25755	5790*	25755
30	762	B22	1361	6054	.087	2.21	1361	6054	1294	5756
		B22A	2610*	11610	.033	.84	2610*	11610	2610*	11610
		B22X	5790*	25755	.017	.43	5790*	25755	5790*	25755
36	914	B22	1135	5049	.126	3.20	1135	5049	899	3999
		B22A	2610*	11610	.057	1.45	2610*	11610	2610*	11610
		B22X	5790*	25755	.029	.73	5790*	25755	5790*	25755
42	1067	B22	972	4323	.172	4.37	972	4323	660	2936
		B22A	2610*	11610	.091	2.31	2610*	11610	2610*	11610
		B22X	5790*	25755	.046	1.17	5790*	25755	5790*	25755
48	1219	B22	851	3785	.224	5.69	758	3372	505	2246
		B22A	2405	10698	.125	3.17	2405	10698	2405	10698
		B22X	5790*	25755	.068	1.73	5790*	25755	5790*	25755
54	1371	B22	756	3363	.284	7.21	599	2664	399	1775
		B22A	2138	9510	.158	4.01	2138	9510	2024	9003
		B22X	5790*	25755	.097	2.46	5790*	25775	5790*	25755
60	1524	B22	681	3029	.351	8.91	485	2157	323	1437
		B22A	1924	8558	.195	4.95	1924	8558	1640	7295
		B22X	5645	25110	.130	3.30	5645	25110	5645	25110
66	1676	B22	619	2753	.424	10.77	401	1784	267	1187
		B22A	1749	7780	.236	5.99	1749	7780	1355	6027
		B22X	5132	22828	.158	4.01	5132	22828	5132	22828
72	1829	B22	567	2522	.505	12.83	337	1499	225	1001
		B22A	1603	7130	.281	7.14	1603	7130	1139	5066
		B22X	4704	20924	.188	4.77	4704	20924	4704	20924
78	1981	B22	524	2331	.593	15.06	287	1276	191	849
		B22A	1480	6583	.330	8.38	1455	6472	970	4315
		B22X	4342	19314	.220	5.59	4342	19314	4270	18994
84	2133	B22	486	2162	.687	17.45	248	1103	165	734
		B22A	1374	6112	.383	9.73	1255	5582	837	3723
		B22X	4032	17935	.255	6.48	4032	17935	3682	16378
90	2286	B22	454	2019	.789	20.04	216	961	144	640
		B22A	1283	5707	.440	11.17	1093	4862	729	3243
		B22X	3763	16738	.293	7.44	3763	16738	3207	14265
96	2438	B22	425	1890	.898	22.81	190	845	126	560
		B22A	1202	5347	.500	12.70	961	4275	640	2847
		B22X	3528	15693	.334	8.48	3528	15693	2819	12539
102	2591	B22	400	1779	1.013	25.73	168	747	112	498
		B22A	1132	5035	.565	14.35	851	3785	567	2522
		B22X	3320	14768	.377	9.57	3320	14768	2497	11107
108	2743	B22	378	1681	1.136	28.85	150	667	100	445
		B22A	1069	4755	.633	16.08	759	3376	506	2251
		B22X	3136	13949	.422	10.72	3136	13949	2227	9906
114	2895	B22	358	1592	1.266	32.15	134	596	90	400
		B22A	1013	4506	.706	17.93	681	3029	454	2019
		B22X	2971	13215	.471	11.96	2971	13215	1999	8892
120	3048	B22	340	1512	1.403	35.63	121	538	81	360
		B22A	962	4279	.782	19.86	615	2735	410	1824
		B22X	2822	12553	.521	13.23	2706	12037	1804	8024

Based on simple beam condition using an allowable design stress of 25000 psi (172 MPa) with adequate lateral bracing. To determine concentrated load capacity at mid span, multiply uniform load by 0.5 and corresponding deflection by 0.8. *Limited by spot weld shear.

B22 COLUMN LOADING DATA



11/12

Unbraced Height		Channel Style	Max. Column Loading $K = .80$				Max. Column Loading (Loaded @ C.G.)					
			Loaded @ C.G.		Loaded @ Slot Face		$K = .65$		$K = 1.0$		$K = 1.2$	
			Lbs.	N	Lbs.	N	Lbs.	N	Lbs.	N	Lbs.	N
12	305	B22	10454	46502	4276	19020	10598	47142	10222	45470	9950	44260
		B22A	21625	96193	7002	31146	21677	96424	21539	95810	21433	95339
		B22X	46948	208835	18975	84405	47061	209338	46761	208003	46531	206980
18	457	B22	9950	44260	4153	18473	10253	45607	9481	42173	8955	39834
		B22A	21433	95339	6959	30955	21551	95863	21239	94476	21001	93417
		B22X	46531	206980	18859	83899	46787	208119	46110	205107	45593	202808
24	609	B22	9311	41417	3993	17762	9801	43597	8582	38174	7801	34700
		B22A	21164	94142	6898	30684	21373	95072	20819	92607	20397	90730
		B22X	45947	204382	18693	84440	46401	206402	45198	201051	44282	196976
30	762	B22	8582	38174	3802	16912	9268	41226	7601	33811	6595	29336
		B22A	20819	92607	6821	30341	21145	94057	20279	90205	19619	87269
		B22X	45198	201051	18485	82225	45906	204200	44026	195837	42593	189463
36	914	B22	7801	34700	3589	15964	8676	38593	6595	29336	5392	23985
		B22A	20397	90730	6728	29927	20866	92816	19619	87269	18669	83044
		B22X	44282	196976	18233	81104	45300	201504	42593	189463	40530	180286
42	1067	B22	6998	31128	3360	14946	8048	35799	5595	24888	4444	19768
		B22A	19898	88511	6620	29447	20537	91353	18840	83804	17546	78048
		B22X	43198	192154	17940	79801	44586	198328	40901	181937	38092	169441
48	1219	B22	6193	27548	3118	13869	7401	32921	4718	20987	3791	16863
		B22A	19322	85948	6496	28895	20157	89663	17940	79801	16251	72288
		B22X	41948	186594	17604	78306	43761	194658	38948	173254	35281	156938
54	1371	B22	5392	23985	2864	12740	6746	30008	4090	18193	3310	14723
		B22A	18669	83044	6263	27859	19726	87745	16920	75264	14782	65753
		B22X	40530	180286	16973	75499	42825	190495	36733	163396	32092	142752
60	1524	B22	4718	20987	2631	11703	6093	27103	3616	16085	2936	13060
		B22A	17940	79801	5340	23753	19244	85601	15781	70197	13141	58454
		B22X	38948	173249	14471	64370	41779	185842	34260	152396	28529	126903
66	1676	B22	4202	18691	2434	10827	5441	24203	3242	14421	2634	11716
		B22A	17134	76216	4587	20404	18712	83235	14521	64592	11328	50389
		B22X	37198	165465	12431	55296	40624	180704	31525	140230	24593	109395
72	1829	B22	3791	16863	2264	10071	4869	21658	2936	13060	2381	10591
		B22A	16251	72288	3968	17650	18129	80642	13141	58454	9524	42365
		B22X	35281	156938	10753	47832	39358	175073	28529	126903	20676	91971
78	1981	B22	3456	15373	2116	9412	4412	19625	2680	11921	2166	9635
		B22A	15291	68018	3456	15373	17496	77826	11642	51786	8115	36097
		B22X	33197	147667	9366	41662	37984	168961	25275	112429	17617	78364
84	2133	B22	3176	14127	1984	8825	4037	17957	2461	10947	1980	8807
		B22A	14255	63409	3028	13469	16812	74783	10076	44820	6998	31128
		B22X	30947	137659	8206	36502	36499	162355	21875	97305	15192	67577
90	2286	B22	2936	13060	1867	8305	3724	16565	2270	10097	1816	8078
		B22A	13141	58454	2667	11863	16077	71514	8778	39046	6096	27116
		B22X	28529	126903	7227	32147	34903	155256	19057	84770	13234	58868
96	2438	B22	2728	16583	1761	7833	3456	15373	2101	9346	1671	7433
		B22A	11951	53160	2359	10493	15291	68018	7715	34318	5357	23829
		B22X	25945	115409	6393	28437	33197	147667	16749	74503	11630	51733
102	2591	B22	2545	11321	1664	7402	3225	14345	1951	8678	1542**	68599
		B22A	10678	47498	2093	9310	14455	64299	6834	30399	4746	21111
		B22X	23182	103118	5672	25230	31382	139594	14836	65994	10303	45830
108	2743	B22	2381	10591	1575	7006	3022	13442	1816	8078	1426**	6343
		B22A	9524	42365	1867	8305	13568	60353	6096	27116	4233	18829
		B22X	20676	91971	5059	22503	29456	131027	13234	58868	9190	40879
114	2895	B22	2234	9937	1494	6645	2842	12642	1694	7535	1322**	5880
		B22A	8548	38023	1675	7451	12630	56181	5471	24336	3799**	16899
		B22X	18558	82550	4539	20190	27420	121970	11877	52831	8247	36684
120	3048	B22	2101	9346	1418	6307	2680	11921	1583**	7041	1228**	5462
		B22A	7715	34318	1512	6726	11642	51786	4937	21961	3429**	15253
		B22X	16749	74503	4097	18224	25275	112429	10718	47676	7444	33112

Column loads assume no lateral support.

** $\frac{KL}{r}$ exceeds 200

12/12

B11SH THRU B56SH

SH TYPE CHANNEL

Part No.	Thickness		Height "H"		Weight	
	In.	mm.	In.	mm.	Lbs./Ft.	kg/m
B11SH	12 Ga.	(2.6)	3 1/4"	(82.5)	2.97	(4.42)
B12SH	12 Ga.	(2.6)	2 7/16"	(61.9)	2.39	(3.55)
B22SH	12 Ga.	(2.6)	1 5/8"	(41.3)	1.82	(2.71)
B24SH	14 Ga.	(1.9)	1 5/8"	(41.3)	1.34	(1.99)
B26SH	16 Ga.	(1.5)	1 5/8"	(41.3)	1.07	(1.59)
B32SH	12 Ga.	(2.6)	1 3/8"	(34.9)	1.62	(2.41)
B42SH	12 Ga.	(2.6)	1"	(25.4)	1.36	(2.02)
B52SH	12 Ga.	(2.6)	1 3/16"	(20.6)	1.19	(1.77)
B54SH	14 Ga.	(1.9)	1 3/16"	(20.6)	.91	(1.35)
B56SH	16 Ga.	(1.5)	1 3/16"	(20.6)	.80	(1.19)

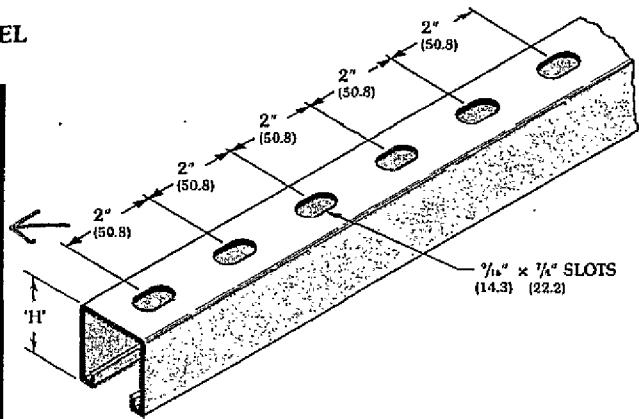

For Beam Loads use 90% of Channel Loading Chart.

B11S THRU B56S

S TYPE CHANNEL

Part No.	Thickness		Height "H"		Weight	
	In.	mm.	In.	mm.	Lbs./Ft.	kg/m
B11S	12 Ga.	(2.6)	3 1/4"	(82.5)	2.94	(4.37)
B12S	12 Ga.	(2.6)	2 7/16"	(61.9)	2.36	(3.51)
B22S	12 Ga.	(2.6)	1 5/8"	(41.3)	1.79	(2.66)
B24S	14 Ga.	(1.9)	1 5/8"	(41.3)	1.32	(1.96)
B26S	16 Ga.	(1.5)	1 5/8"	(41.3)	1.06	(1.58)
B32S	12 Ga.	(2.6)	1 3/8"	(34.9)	1.59	(2.36)
B42S	12 Ga.	(2.6)	1"	(25.4)	1.33	(1.98)
B52S	12 Ga.	(2.6)	1 3/16"	(20.6)	1.16	(1.72)
B54S	14 Ga.	(1.9)	1 3/16"	(20.6)	.89	(1.32)
B56S	16 Ga.	(1.5)	1 3/16"	(20.6)	.79	(1.17)

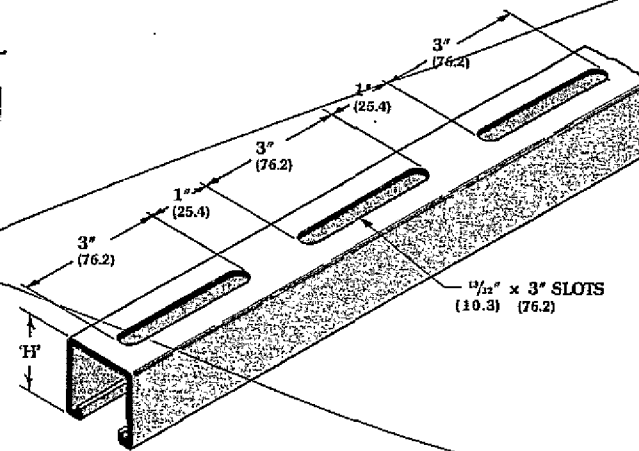

For Beam Loads use 90% of Channel Loading Chart.

B11H-1 7/8 THRU B56H-1 7/8 H-1 7/8 TYPE CHANNEL

Part No.	Thickness		Height "H"		Weight	
	In.	mm.	In.	mm.	Lbs./Ft.	kg/m
B11H1 7/8	12 Ga.	(2.6)	3 1/4"	(82.5)	3.00	(4.46)
B12H1 7/8	12 Ga.	(2.6)	2 7/16"	(61.9)	2.42	(3.60)
B22H1 7/8	12 Ga.	(2.6)	1 5/8"	(41.3)	1.85	(2.75)
B24H1 7/8	14 Ga.	(1.9)	1 5/8"	(41.3)	1.36	(2.02)
B26H1 7/8	16 Ga.	(1.5)	1 5/8"	(41.3)	1.09	(1.62)
B32H1 7/8	12 Ga.	(2.6)	1 3/8"	(34.9)	1.65	(2.45)
B42H1 7/8	12 Ga.	(2.6)	1"	(25.4)	1.39	(2.07)
B52H1 7/8	12 Ga.	(2.6)	1 3/16"	(20.6)	1.22	(1.81)
B54H1 7/8	14 Ga.	(1.9)	1 3/16"	(20.6)	.93	(1.38)
B56H1 7/8	16 Ga.	(1.5)	1 3/16"	(20.6)	.82	(1.22)

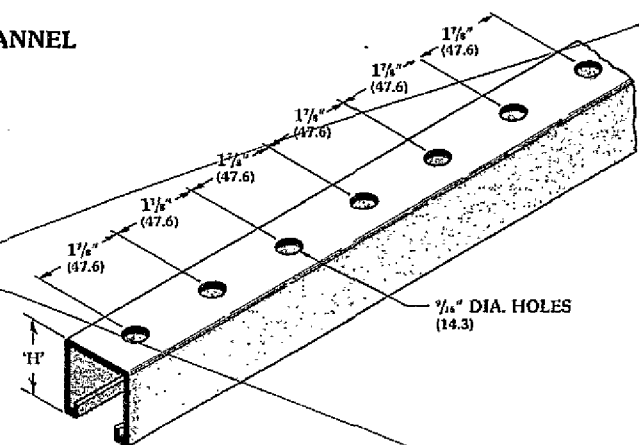

For Beam Loads use 90% of Channel Loading Chart.

STANDARD FINISHES: Plain Steel (oil coated), Dura-Green or Pre-Galvanized.
STANDARD LENGTHS: 10' (3.05 m) & 20' (6.09 m)

Project: Nella Oil #279
Canopy

Craig A. Rowland, P.E.
17924 Lake Arthur Road
Applegate, CA 95703
(530) 878-9990
(530) 878-4532

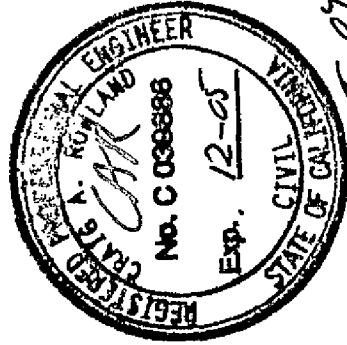

20 OCT 04

1-1 Direction Vertical Profile:

of Stories (1, 2, or 3):
 Roof Average Height (ft):
 Average Column Height (ft):
 Roof Horv. Projected Area: 358.00
 Wall Horv. Projected Area: 72.00
 Total Horv. Projected Area: 430.00

A-A Direction Vertical Profile:

Concrete slab first floor (Y or N)? # of Stories: 1
 Roof Average Height (ft):
 Average Column Height (ft):
 Roof Horv. Projected Area: 220.00
 Wall Horv. Projected Area: 72.00
 Total Horv. Projected Area: 292.00

Dead Load (DL) Summary in PSF:

Roof DL:
 50% Snow Load:
 PV DL:
 Exterior Wall DL:
 Interior Wall DL:

Roof (include overhang):
 Area (sq ft) 2035
 Area Ceiling: 2035
 50% Snow Load: 2035
 Area Wall: 144
 Weight #s
 18315
 6105
 0
 3600

Weight #s

Building Weight:

3rd Floor:
 Floor Area (sq ft): 0
 Ex Wall Area: 0
 In Wall Area: 0
 Manual Adjustment (#s): 0
 Weight #s: 0
 Roof Diaphragm Weight: 28020

2nd Floor:

Floor Area (sq ft): 0
 Ex Wall Area: 0
 In Wall Area: 0
 Manual Adjustment (#s): 0
 Weight #s: 0
 3rd Floor Diaphragm Weight: 0

1st Floor:

Floor Area (sq ft): 0
 Ex Wall Area: 0
 In Wall Area: 0
 Manual Adjustment (#s): 0
 Weight #s: 0
 2nd Floor Diaphragm Weight: 0
 0 (0 for slab)
 0
 0
 0
 0
 1st Floor Diaphragm Weight: 28020

Total Seismic Base Weight (W): 28020

Project: Nella Oil #279
Canopy

BASE & STORY SHEAR (#S)

WIND: Velocity: 80 Exposure: B Bldg Height: 25 Wind 1-1 Horz. Wind A-A Horz.
 $C_e = 0.72$ $C_q = 1.3$ $q_s = 16.4$ $I_w = 1$ Roof Shear 5004 6601 4482
 $V_w = C_e C_q q_s I_w A = 15.4 A$

SEISMIC: Zone: 3 Soil Profile: S_D Base Shear 5004 6601 4482
 $C_s = 0.44$ $N_s = 1.5$ $I = 1$ $R = 4.4$

$V_s = 0.11 C_a I = 0.250 W/1.4$ (Working Stress Design)

Wind Dominates 1-1 Direction, Seismic A-A Direction

Column Footing Design
Constrained Columns With Square Footing

Number of Columns 4 Diag (b) 5.64 FT Depth (d) 4.92 FT
Footing Area 16 SF

Total load 6601 LBS

Load per Column (P) 1650 LBS

Point of Load on Column (h) 18 FT

UBC Table 18-1-A Allowable Lateral Load 100 PSF

$S_3 = \text{Total Adjusted Lateral Load} = \text{Table 18 Load X 2 X (Depth of Footing-1) X 1.33} = 1042.72 \text{ PSF}$

Required Depth, $D = S_q \text{ Rt of } (4.25 \cdot P \cdot h) / (S^3 \cdot b)$ 4.63 FT

Required footing depth must be less than 4.92 FT

Bearing on Footing 438 PSF

Project: Nella Oil #279
Canopy

BASE & STORY SHEAR (#S)

WIND: Velocity: 80 Exposure: B Bldg Height: 25 Wind 1-1 Horz. 6601 Wind A-A Horz. 4482
 $C_e = 0.72$ $C_q = 1.3$ $q_s = 16.4$ $I_w = 1$
 $V_w = C_e C_q I_w A = 15.4 A$ Roof Shear 5004
SEISMIC: Zone: 3 Soil Profile: S_b Base Shear 5004
 $C_a = 0.44$ $N_s = 1.5$ $I = 1$ $R = 4.4$

$V_s = 0.11 C_a I = 0.250 W/1.4$ (Working Stress Design)

Wind Dominates 1-1 Direction, Seismic A-A Direction

Column Footing Design
Constrained Columns Round Footing

Number of Columns 4 Dia (b) 4 FT Depth (d) 5.5 FT Footing Area 12.56 SF

Total load 6601 LBS

Load per Column (P) 1650 LBS

Point of Load on Column (h) 18 FT

UBC Table 18-1-A Allowable Lateral Load 100 PSF

$S_3 = \text{Total Adjusted Lateral Load} = \text{Table 18 Load X 2 X (Depth of Footing-1) X 1.33} = 1197 \text{ PSF}$

Required Depth, D = Sq Rt of $(4.25 \cdot P \cdot h) / (S_3 \cdot b)$ 5.13 FT

Required footing depth must be less than 5.5 FT

Bearing on Footing 558 PSF

W/PV

Project: Existing Nella Oil #279 Store

BASE & STORY SHEAR (#S)

WIND:
 Velocity: Exposure: Bldg Height:
 $C_e =$ $C_q =$ $q_s =$ $w_w =$
 $V_w = C_e C_q q_s I_w A = 14.3 A$

SEISMIC:
 Zone: Soil Profile:
 $C_p =$ $N_s =$ $R =$
 $V_s = 2.5 C_a I/R = 0.250 W/1.4$ (Working Stress Design)

Seismic 5363
 Wind 1-1 Horz. 17148
 Wind A-A Horz. 8399
 Roof Shear 5363
 Base Shear 7050
 21698
 10999

Shear in 11 direction 1/2 SHEAR 8574 LBS WALL LENGTH 15 FT SHEAT 572 PLF
 Shear in AA direction 4200 LBS 20 FT 210 PLF

MUST VERIFY WALL AND BRACING CONDITIONS DURING CONSTRUCTION AND DESIGN ADEQUATE RESISTANCE INTO BRACING SYSTEM. (IF CMU OK) OK

JOB: Nella Oil 279

Craig A. Rowland, P.E.
 17924 Lake Arthur Road
 Applegate, CA 95703
 (530) 878-9990
 FAX (530) 878-4552

Load Determination

Roof Live Load	20.0 psf
Ceiling Live Load	- psf
Floor Live Load	- psf
Deck Live Load	- psf

Roof Dead Load	
PV unit	2.7 psf
Uni Strut B22	0.4 psf
Existing roof system	9.0 psf
Insulation	- psf
1/2 gypsum	- psf
Misc.	- psf
Dead load	12.0 psf
Live load	20.0 psf
Total Load	32.0 psf

Ceiling Dead Load	
Insulation	- psf
1/2 gypsum	- psf
Joists	- psf
Misc.	- psf
Dead load	- psf
Live load	- psf
Total Load	- psf

Total Roof / Ceil System 32.0 psf

Floor Dead Load	
Insulation	- psf
3/4 ply	- psf
Joist	- psf
1/2 gypsum	- psf
Misc.	- psf
Dead load	- psf
Live load	- psf
Total Load	- psf

Deck Dead Load	
2 x decking	- psf
Joist	- psf
Misc.	- psf
Dead load	- psf
Live load	- psf
Total Load	- psf

All Table Values in psf

Trusses	12" OC	16" OC	24" OC
2 x 4	6.0	4.0	3
2 x 6	9.0	6.0	4.5
2 x 8	12.0	8.0	6

0.166667

Framing	12" OC	16" OC	24" OC
2x4	1.3	1.0	0.7
2x6	2.1	1.6	1.0
2x8	2.7	2.1	1.4
2x10	3.5	2.6	1.7
2x12	4.3	3.2	2.1

Decking	2"	3"	4"
DF	4.5	7.6	10.6
Pine	3.7	6.2	8.6
Redwood	3.3	5.5	7.7
Cedar	3.3	5.5	7.7

Gypsum	
1/2	2.0 psf
5/8	2.5 psf

Insulation	
R11	0.3 psf
R19	0.5 psf
R30	0.8 psf
R38	1.0 psf

Ply	
3/8	1.3 psf
1/2	1.8 psf
5/8	2.2 psf
3/4	2.6 psf
1 1/8	3.9 psf
1 1/4	4.4 psf

Plaster	9 psf
Concrete	50 psf
Foam Ins.	0.3 psf
1" Hard Wd.	4.5 psf
Windows	10 psf

JOB: NELLA OIL 279 STEEL BEAM UNIFORM & TOTAL LOADS

BEAM	SPAN LOAD		REACTIONS		MOMENT		STEEL		I	S	Aw	MOD. E	F _b	f _b	DEFLECTION		
	L	w	R ₁	R ₂	M _{max}	M _{max}	S REQD	F _y							Δ _{ALLOW}	Δ	
	feet	plf	lbs	lbs	in-lbs	in-lbs	in ³	ksi	in	in	si	psi	psi	in	in	U	
A	15.0	512	3840	3840	172,800	172,800	7.3	36.0	98	24.3	2.1	2.9E+07	23760	2783	0.75	0.21	240
B	12.5	512	3200	3200	120,000	120,000	5.1	36.0	98	24.3	2.1	2.9E+07	23760	2319	0.63	0.10	240
C	17.0	440	3740	3740	190,740	190,740	8.0	36.0	98	24.3	2.1	2.9E+07	23760	2710	0.85	0.29	240
D	12.3	880	5390	5390	198,083	198,083	8.3	36.0	375	38.4	3.9	2.9E+07	23760	2061	0.61	0.04	240
E	29.0	332	4814	4814	418,818	418,818	17.6	36.0	199	29.0	3.2	2.9E+07	23760	2285	1.45	0.92	240

Δ_{ALLOW} EQUALS L/360 FOR FLOOR OR COMBINATION LOADING, L/240 FOR ROOF LOADING.

Project: Pacific Power PV System
Nella Oil #279

BASE & STORY SHEAR (KSI)

WIND: Velocity: Exposure: Bldg Height:
 $C_e =$ $C_d =$ $q_s =$ $I_w =$
 $C_q = 1.7$ if Horiz Angle is less than 16 degrees - 1.6 if more than 16 degrees

$V_w = C_e C_d q_s I_w A = 20.1 A$ Horiz. Force Roof Shear Wind Uplift
 Uplift Force 2nd Floor Shear

SEISMIC: Zone: Soil Profile: $R =$
 $C_e =$ $N_e =$ Base Shear

$V_s = 2.5 C_s I/R = 0.250 W/1.4$ (Working Stress Design)

Wind Dominates Both Directions

Uplift Force per lineal foot of PV Panel and Frame or

Horz. Force per lineal foot of PV Panel and Frame or

Hold downs required and per foot of PV Frame

Project: Pacific Power PV System
Nella Oil #279

Craig A. Rowland, P.E.
17924 Lake Arthur Road
Applegate, CA 95703
(530) 878-9990
(530) 878-4552

1-1 Direction Vertical Profile:

of Stories (1, 2, or 3):

Roof Average Height (ft):

Concrete slab first floor (Y or N)?

Roof Width (ft):

Uplift Direction Vertical Profile:

of Stories: 1

Average Panel Length (ft):

Roof Width (ft):

Roof Horv. Projected Area: 2.89

Vert Rise: 2.35

Panel Angle to Horv.: 15.46

Roof Vert. Projected Area: 10.85

Horz. Run: 8.50

Total Height: 2.89

Dead Load (DL) Summary in PSF:

Roof DL:

50% Snow Load:

Ceiling DL:

Exterior Wall DL:

Interior Wall DL:

3rd Floor DL:

2nd Floor DL:

1st Floor DL:

Building Weight:

	Weight #s	Weight #s
Roof (include overhang):	10.85	32.55
Area (sq ft)	10.85	0
Area Ceiling:	10.85	0
50% Snow Load:	10.85	0
Area Wall:	0	0
3rd Floor:	0	0
Floor Area (sq ft):	0	0
Ex Wall Area:	0	0
In Wall Area:	0	0
Manual Adjustment (#s):	0	0
2nd Floor:	0	0
Floor Area (sq ft):	0	0
Ex Wall Area:	0	0
In Wall Area:	0	0
Manual Adjustment (#s):	0	0
1st Floor:	0	0
Floor Area (sq ft):	0	0
Ex Wall Area:	0	0
In Wall Area:	0	0
Manual Adjustment (#s):	0	0
Roof Diaphragm Weight:		33
3rd Floor Diaphragm Weight:		0
2nd Floor Diaphragm Weight:		0
1st Floor Diaphragm Weight:		33

Total Seismic Base Weight (W): 33

JH-3500U

MULTI-STRING INVERTER

3500W Inverter

ELECTRICAL CHARACTERISTICS

Maximum system voltage (DC)	380V
Rated input voltage (DC)	240V
Range of operating DC voltage (DC)	110V - 350V
Maximum array short circuit current (DC)	10A
Maximum operating current (DC)	22.5A (7.5A per DC input x 3)
Nominal output voltage (AC)	240V
Operating voltage range (AC)	211V - 264V
Nominal output frequency (AC)	60Hz
Operating frequency range (AC)	59.3Hz - 60.5Hz
Maximum continuous output current (AC)	15A
Maximum continuous output power (AC)	3500W (at DC input 160-320V)
Maximum input power (DC)	4500W
Peak conversion efficiency	92.4%
Power factor	More than 0.95
Total harmonic distortion (THD)	Less than 5%
Operating temperature	Inverter: -4°F to 104°F / -20°C to +40°C LCD Display: 32°F to 104°F / 0°C to +40°C

MAIN CIRCUIT

Solar power conditioner system	Fixed voltage current control system
Switching system	PWM (pulse width modulation) system
Isolation system	Built-in High frequency isolation transformer system
Electric system	1-phase 2-wire system (not connect to 1-phase 3-wire system)

PROTECTION

Grid-connected protection	AC Over Voltage / Under Voltage, AC Over Frequency / Under Frequency detector and anti-arcing component (IEEE429)
Ground fault protection	DC detector / interrupter

MECHANICAL CHARACTERISTICS

Dimensions (W x D x H)	Inverter: 23.7 x 17.8 x 7.65" / 600 x 450 x 197mm LCD Display: 5.4 x 4.61 x 0.87" / 137 x 117 x 22mm
Weight	Inverter: Approx. 51.7 lbs / 23 kg LCD Display: Approx. 3.44 lbs / 0.2 kg
Enclosure type	ALUMA 3R

DIMENSIONS

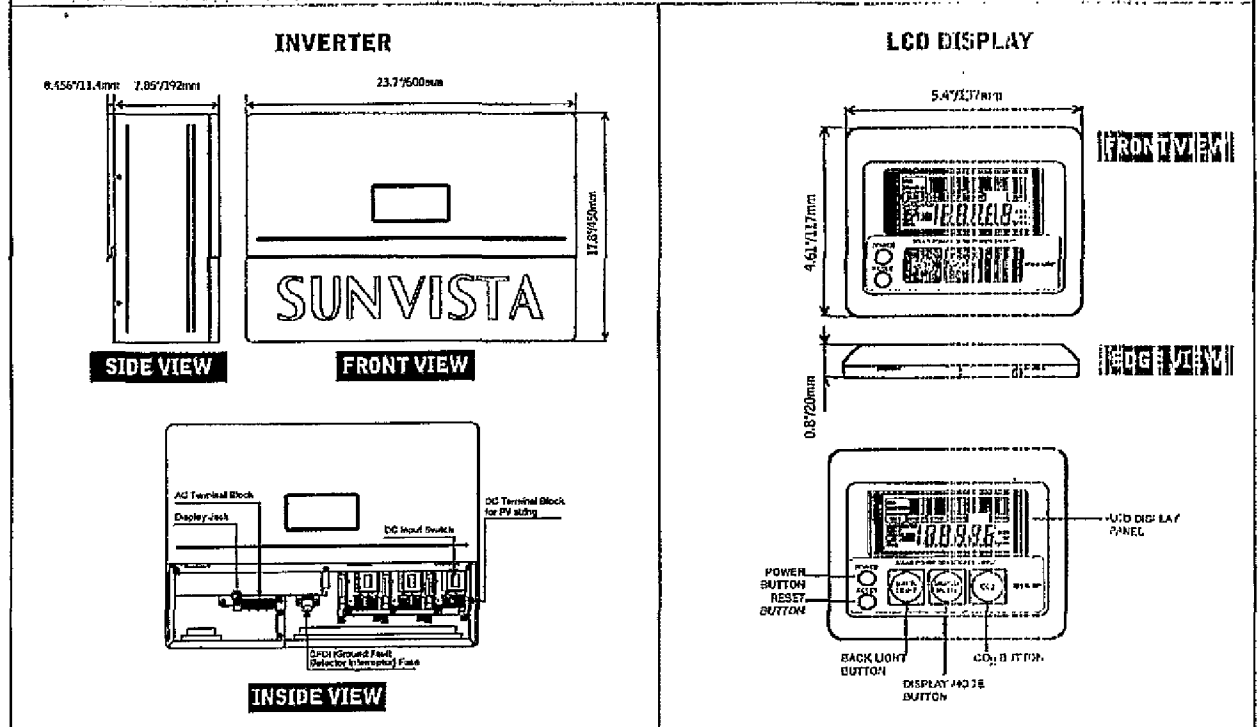

Specifications are subject to change without notice.

In the absence of confirmation by product manuals, Sharp takes no responsibility for any defects that may occur in equipment using any Sharp devices. Contact Sharp to obtain the latest product manuals before using any Sharp device.



MULTI-PURPOSE MODULE

Cell	Single crystal silicon
No. of Cells and Connections	72 in series
Open Circuit Voltage (Voc)	44.9V
Maximum Power Voltage (Vpm)	36.2V
Short Circuit Current (Isc)	5.75A
Maximum Power Current (Ipm)	5.11A
Maximum Power (Pm)*	185W
Minimum Power (Pm)*	166.5W
Encapsulated Solar Cell Efficiency (ηc)	17.48%
Module Efficiency (ηm)	14.23%
PTC Rating (W)**	162.43
Maximum System Voltage	600VDC
Series Fuse Rating	10A
Type of Output Terminal	Lead Wire with MC Connector

Dimensions (A x B x C below)	69.03 x 19.42 x 30.93 / 2.675 x 0.766 x 1.213
Weight	37.485lb., 17.0kg
Packing Configuration	2 pcs per carton
Size of Carton	66.93 x 33.27 x 5.12 / 1.60 x 0.84 x 1.31
Loading Capacity (20 ft container)	168 pcs (84 cartons)
Loading Capacity (40 ft container)	392 pcs (196 cartons)

Operating Temperature	-10 to 194°F / -10 to +90°C
Storage Temperature	-40 to 194°F / -40 to +90°C
Dielectric Isolation Voltage	>>60 VDC max.

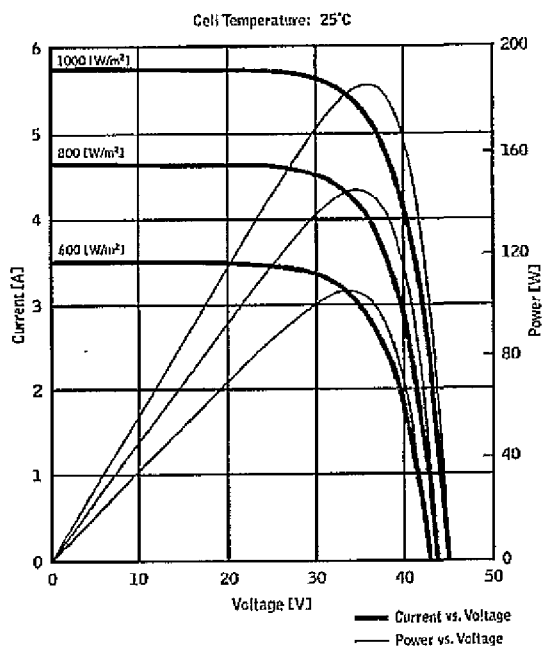

Current, Power vs. Voltage Characteristics

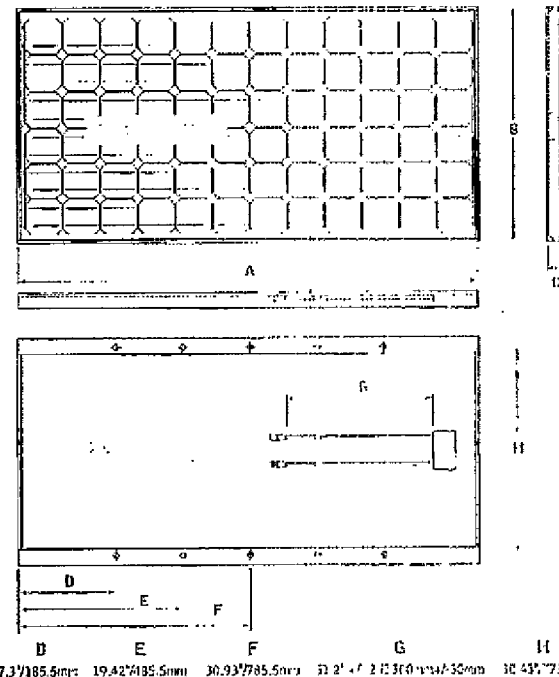

Specifications are subject to change without notice.

* (STC) Standard Test Conditions: 25°C, 1 kW/m², AM 1.5
 ** (PTC) Pacific Test Conditions: 20°C, 1 kW/m², AM 1.5, 1 m/s wind speed

In the absence of confirmation by product manuals, Sharp takes no responsibility for any defects that may occur in equipment using any Sharp devices. Contact Sharp to obtain the latest product manuals before using any Sharp device.

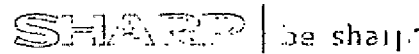

Sharp Electronics Corporation • 5901 Bolsa Avenue, Huntington Beach, CA 92647
 Tel: 1-800-SOLAR-06 • E-mail: sharpsolar@sharpusa.com • www.sharpusa.com/scl





License Detail

CALIFORNIA CONTRACTORS STATE LICENSE BOARD

Contractor License # 840482

DISCLAIMER

A license status check provides information taken from the CSLB license data base. Before relying on this information, you should be aware of the following limitations:

- CSLB complaint disclosure is restricted by law (B&P 7124.6). If this entity is subject to public complaint disclosure, a link for complaint disclosure will appear below. Click on the link or button to obtain complaint and/or legal action information.
- Per B&P 7071.17, only construction related civil judgments known to the CSLB are disclosed.
- Arbitrations are not listed unless the contractor fails to comply with the terms of the arbitration.
- Due to workload, there may be relevant information that has not yet been entered onto the Board's license data base.

Extract Date: 10/27/2004

***** Business Information *****

PACIFIC POWER MANAGEMENT
 12970 EARHART AVENUE SUITE 110
 AUBURN, CA 95602
 Business Phone Number: (530) 887-1984

Entity: **Partnership**
 Issue Date: **06/10/2004** Expire Date: **06/30/2006**

***** License Status *****

This license is current and active. All information below should be reviewed.

***** Classifications *****

Class	Description
B	GENERAL BUILDING CONTRACTOR

Handwritten: Paper 6377

Stamp: RECEIVED
 OCT 27 2004
 11:37 AM
 11377

***** Bonding Information *****

CONTRACTOR'S BOND: This license filed Contractor's Bond number **899013C** in the

amount of \$10,000 with the bonding company
DEVELOPERS SURETY AND INDEMNITY COMPANY.
Effective Date: 01/01/2004

BOND OF QUALIFYING INDIVIDUAL(1): A qualifying partner is **not** required to post a bond of qualifying individual.

***** Workers Compensation Information *****

This license has workers compensation insurance with the
STATE COMPENSATION INSURANCE FUND
Policy Number: 1788661 Effective Date: 05/26/2004 Expire Date: 05/01/2005

Personnel listed on this license (current or disassociated) are listed on other licenses.

Personnel List Other Licenses

License Number Request

Contractor Name Request

Personnel Name Request

Salesperson Request

Salesperson Name Request

© 2004 State of California. Conditions of Use Privacy Policy



PACIFIC POWER
 12970 EARHART AVE.
 SUITE 110
 ALBUQUERQUE, NM 87102
 TEL 505-887-1984
 FAX 505-887-1986

NELLA OIL STATION #279
 921 SEBASTOPOL ROAD
 SANTA ROSA, CA

PROJECT #	X
DRAWN BY	MKE/M
DATE	9/13/04
CHECKED BY	X
REVISIONS	
TITLE	SITE PLAN, PV
TOTALS	VICINITY MAP
SHEET #	PVI

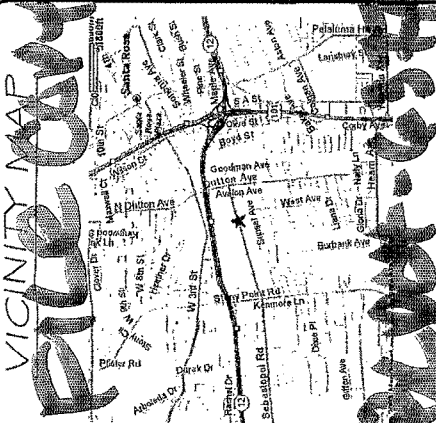

SITE TABLE

OWNER: NELLA OIL COMPANY
 2349 RICKEN BACKER WAY
 ALBUQUERQUE, NM 87102
 JOB ADDRESS: 921 SEBASTOPOL ROAD
 SANTA ROSA, CA
 APN: 125-101-047
 ZONING: P-1 (COMMERCIAL BUSINESS)
 X 125-101-047

PERMIT NO. **P.V. 102704**
 STORE: **125-101-047**
 PERMIT AND RESOURCE MANAGEMENT DEPARTMENT
 APPROVED JOB COPY OF PLANS AND JOB CARDS TO BE ON JOB SITE.

ALL INFORMATION INDEXED
 REQUESTS FOR INFORMATION FROM COMPLETE APPROVAL OF THIS ELEVATION SUBJECT TO, AND DEVICES NOT AUTHORIZED DEVIATION FROM COMPLETE COMPLIANCE WITH ALL REQUIREMENTS, SPECIAL INSPECTIONS WHEN REQUIRED AND FIELD INSPECTION WITHOUT PREVIOUS NOTICE SHALL BE SUBJECT TO REJECTION OF THE PERMIT.
 CANOPY PERMITS READ ALL PERTINENT SECTIONS OF APPLICABLE CODES FOR STORE ROOF DETAILS PV6
 INVERTER LAYOUT PV7
 ONE-LINE DIAGRAM

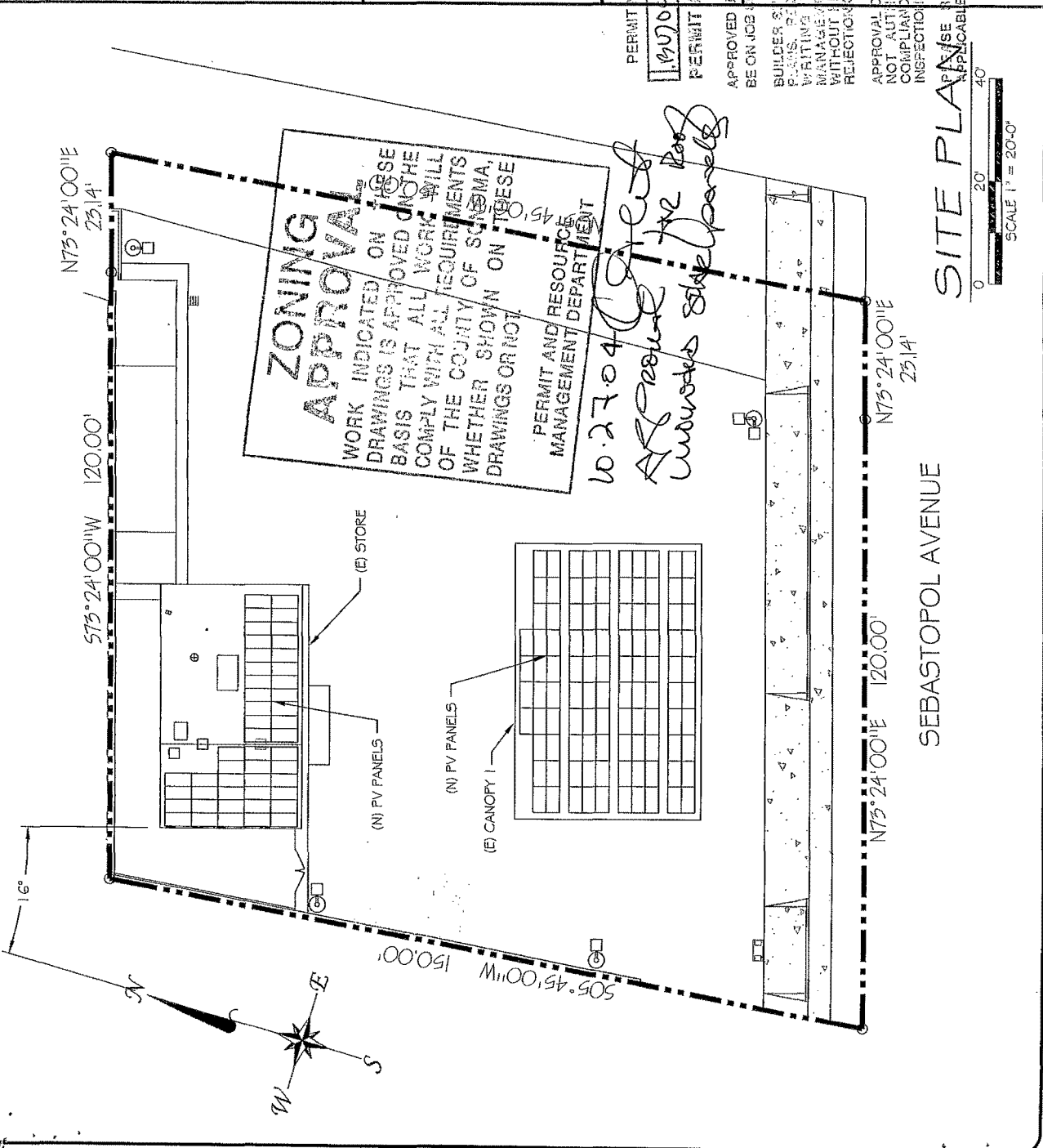

PACIFIC POWER
 12970 EARBART AVE.
 SUITE 110
 ALBURN, CA 95602
 TEL. 530-857-1984
 FAX 530-857-1986

NELLA OIL STATION #279

921 SEBASTOPOL ROAD
 SANTA ROSA, CA

PROJECT #: X

DRAWN BY: MIKE M

DATE: 9/13/04

CHECKED BY: X

REVISIONS:

TITLE:

PV PANEL LAYOUT

SHEET #:

PV2

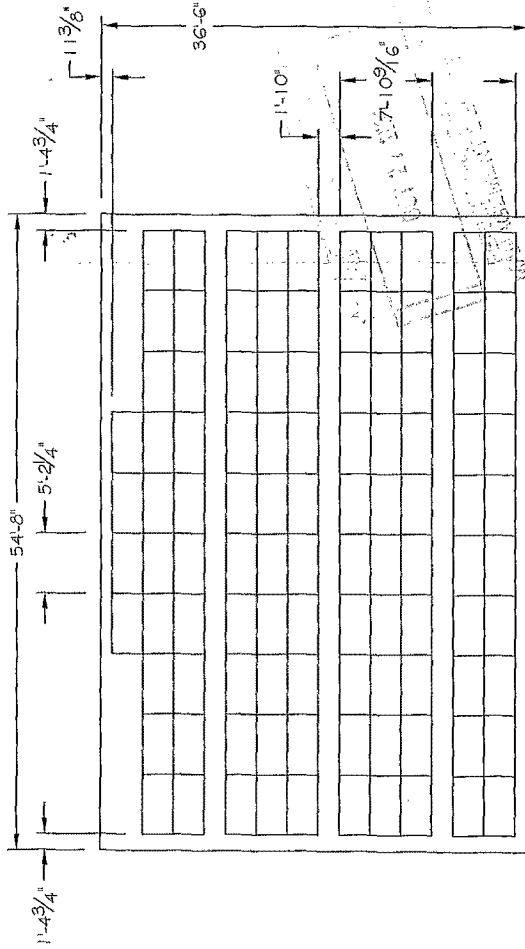

CANOPY #1 P.V. LAYOUT
 SCALE 3/8" = 1'-0"
 104 MODULES

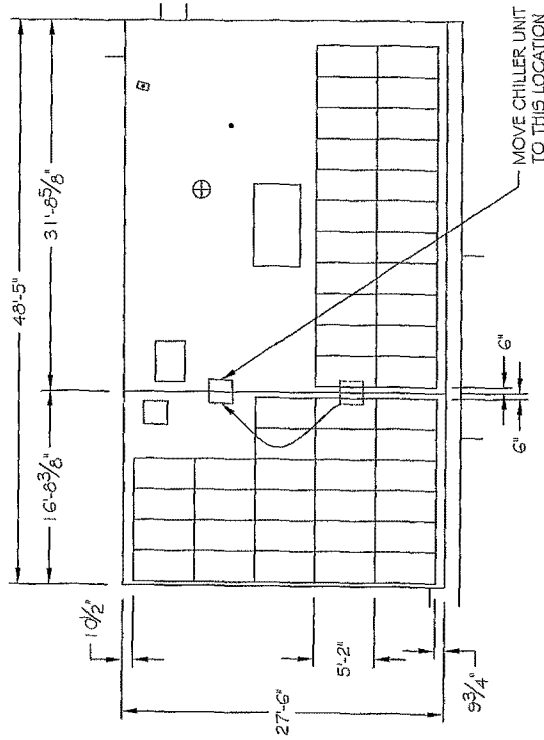

STORE ROOF P.V. LAYOUT
 SCALE 3/8" = 1'-0"
 48 MODULES

PACIFIC POWER
 12970 EARHART AVE.
 SUITE 110
 ALBURN, CA 95602
 TEL 950-887-1984
 FAX 950-887-1986

921 SEBASTOPOL ROAD
 SANTA ROSA, CA

NFLA OIL STATION #279

PROJECT #	X
DRAWN BY	M. KEM
DATE	9/13/04
CHECKED BY	X
REVISIONS	
TITLE	ROOF FRAMING PLAN
SHEET #	PV4

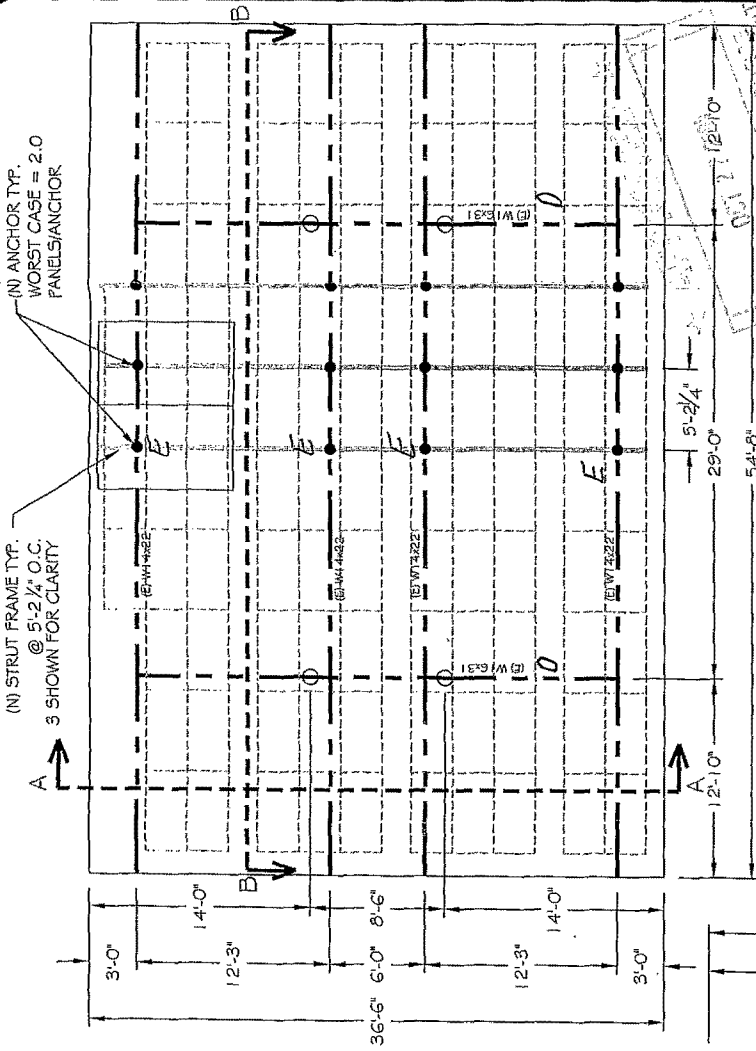

CANOPY #1 FRAMING PLAN
 SCALE 1/8" = 1'-0"



ORIGINAL DESIGN CRITERIA:
 DEAD LOAD CANOPY ROOF - 8.9 psf
 LIVE LOAD ALL ROOFS - 20 psf (reducible)
 WIND LOAD - 80 mph EXP. '1C'
 HORIZONTAL = 23.64 psf
 UPLIFT = 21.83 psf

COLUMN/FOOTING SCHEDULE:
 TYP. 12" x 24" x 25' COLUMN
 4'-0" Ø 15" - 6" DP or
 4'-0" 150 x 150 x 11" DP

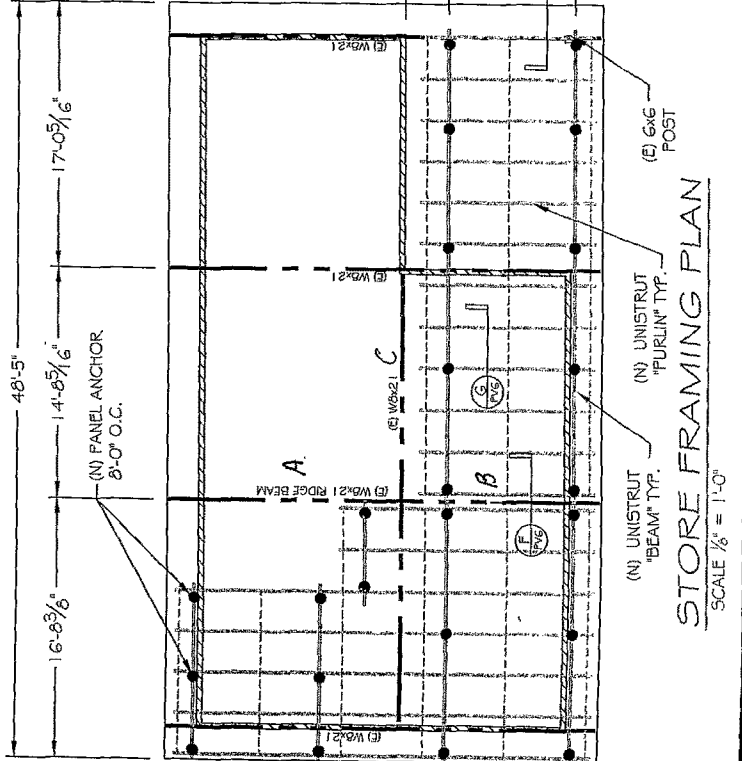

STORE FRAMING PLAN
 SCALE 1/8" = 1'-0"



12970 EARHART AVE.
SUITE 110
ALBURN, CA 95602
TEL 930-887-1984
FAX 930-887-1986

NELLA OIL STATION #279

921 SEBASTOPOL ROAD
SANTA ROSA, CA

PROJECT # X

DRAWN BY: MIKE M

DATE: 9/13/04

DESIGNED BY: X

REVISIONS:

TITLE:

CANOPY DETAILS

SHEET #:

PV5

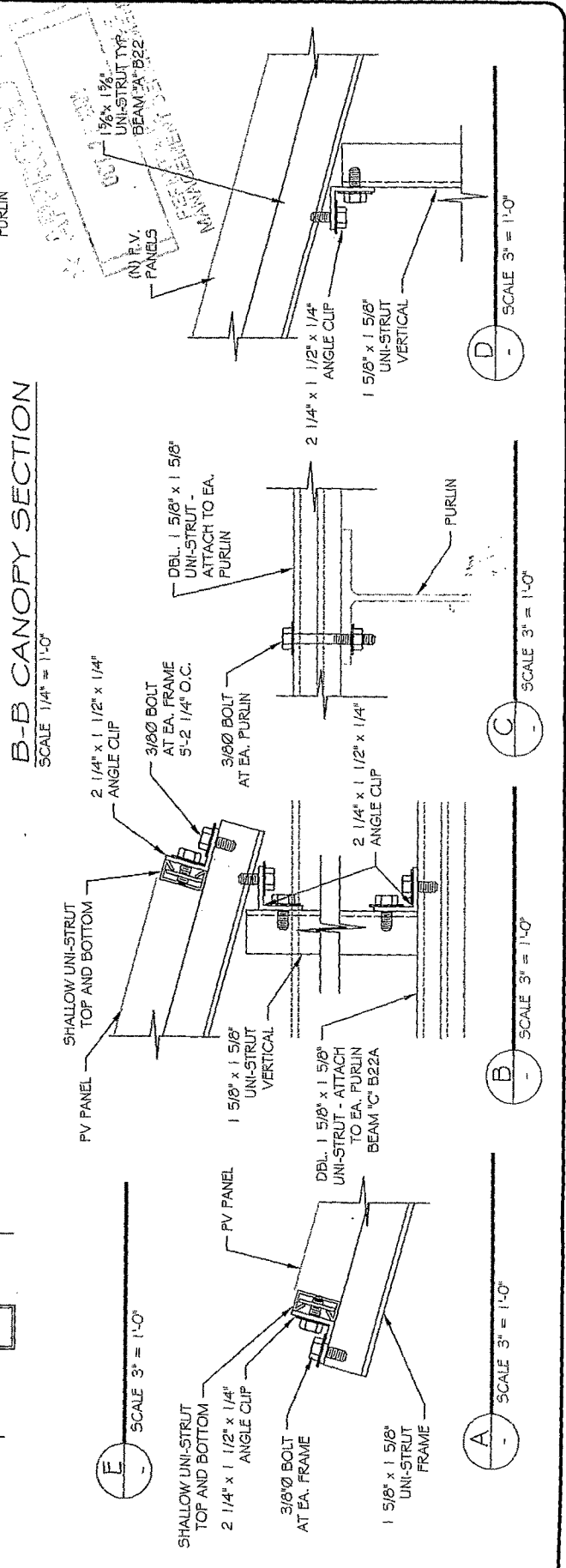
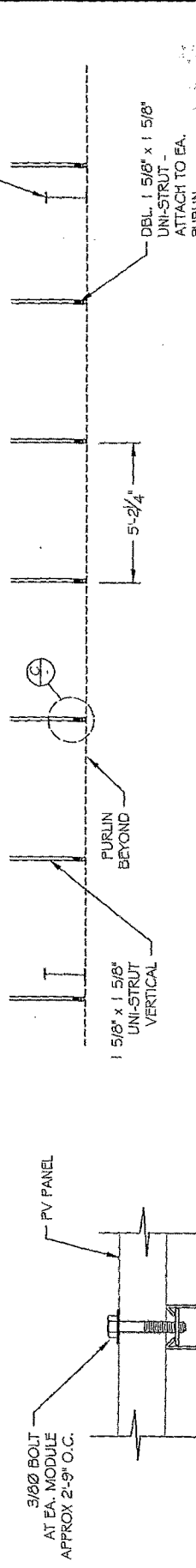
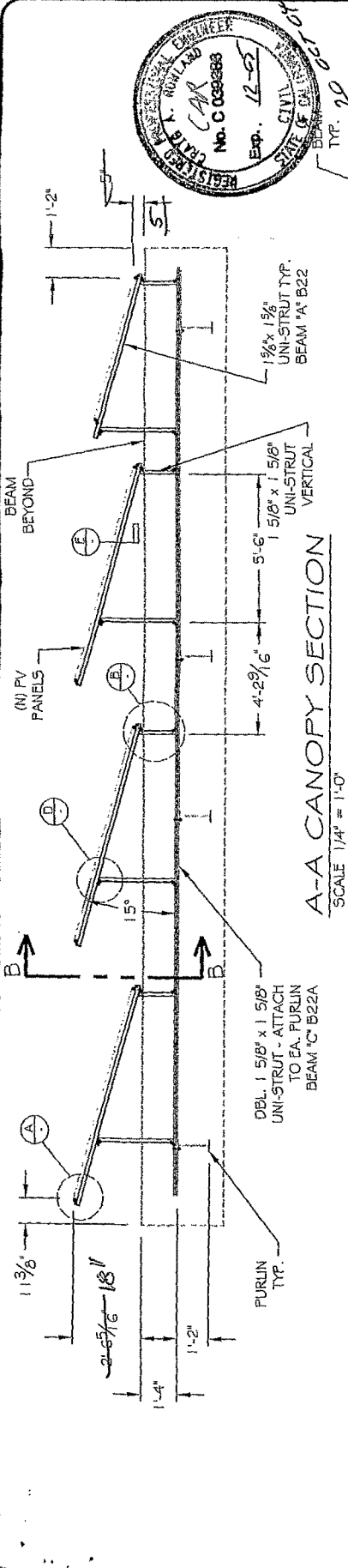
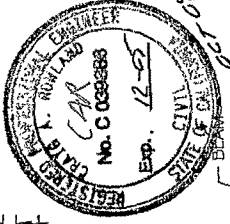

PACIFIC POWER
 12970 EARRHART AVE.
 SUITE 110
 ALBURN, CA 95602
 TEL 920-887-1984
 FAX 920-887-1986

NELLA OIL STATION #279
 921 SEBASTOPOL ROAD
 SANTA ROSA, CA

PROJECT #	X
DRAWN BY	MICELM
DATE	9/13/04
CHECKED BY	X
REVISIONS	
TITLE	STORE DETAILS
SHEET #	PV6

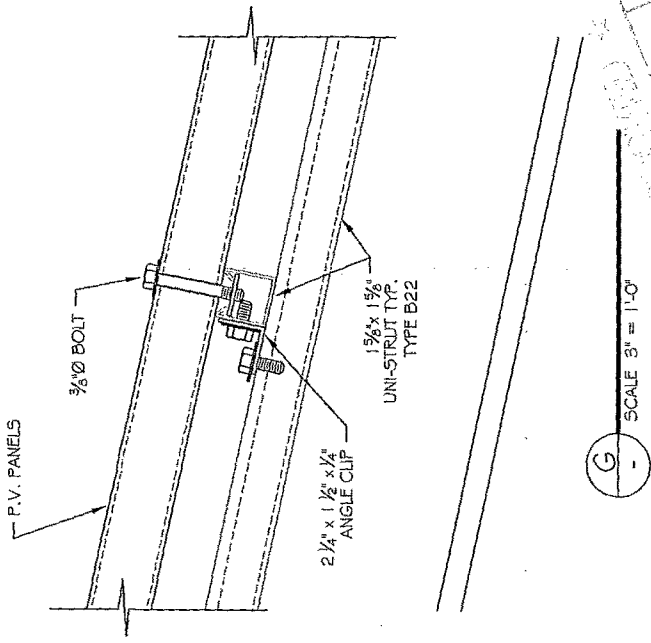

MANAGED BY: CIVIL ENGINEER
 No. C 033389
 Exp. 12-05
 CIVIL ENGINEER
 STATE OF CALIFORNIA
 200

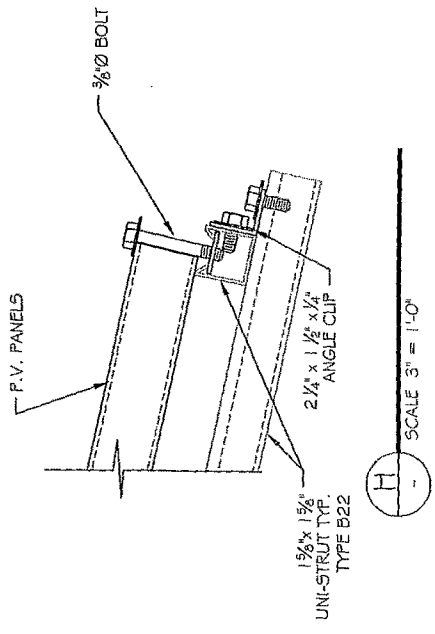
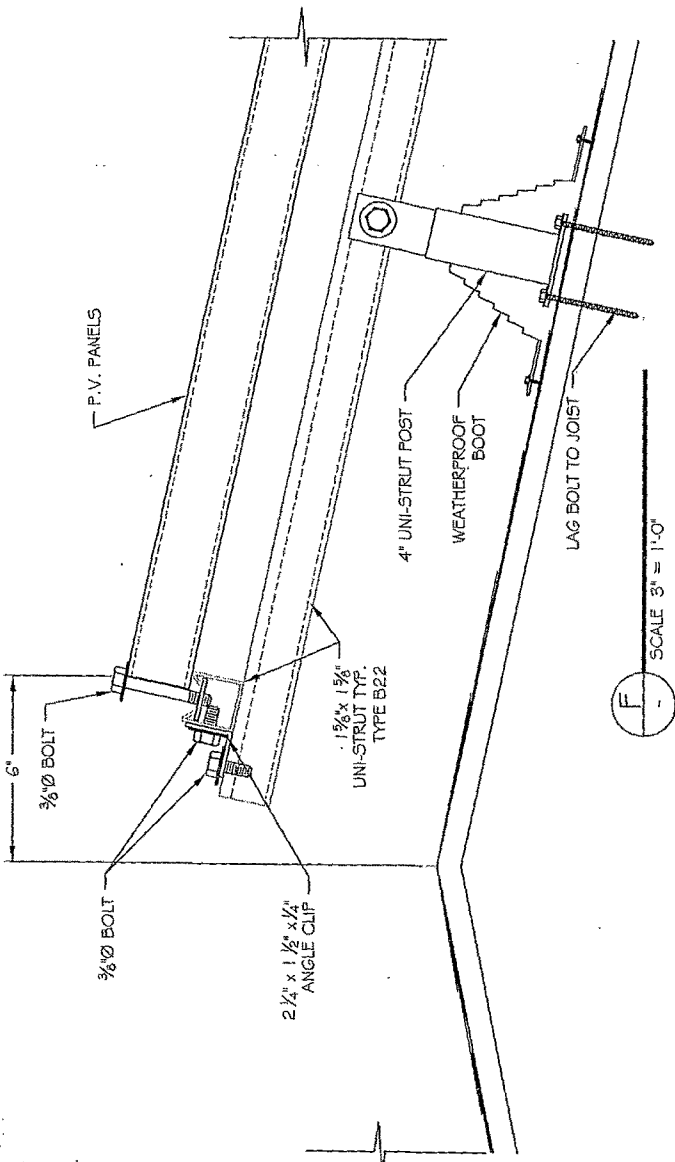
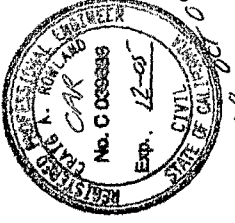

PACKER POWER
 12970 ENRIART AVE.
 SUITE 110
 ALBANY, CA 95602
 TEL 530-887-1984
 FAX 530-887-1986

NELLA OIL STATION #279
 921 5FBASTOPOL ROAD
 SANTA ROSA, CA

PROJECT #:	X
DESIGNED BY:	MKZ/M
DATE:	9/13/04
CHECKED BY:	X
REVISIONS:	
TITLE:	ONE-LINE & INVERTER LAYOUT
SHEET #:	PV7

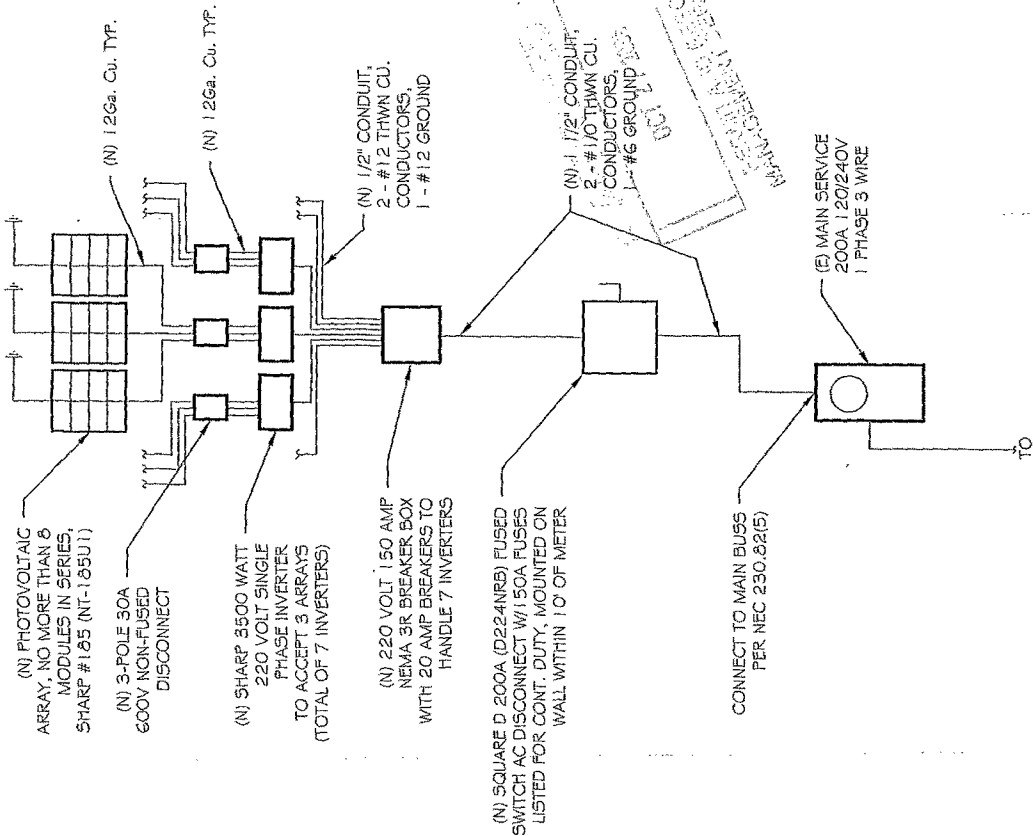

NOTE:
 10GA COPPER GROUND TIED
 TO CANOPY, SUPPORTS,
 FRAMES, DISCONNECTS,
 INVERTERS, DISTRIBUTION
 BOX, CONDUIT, BUILDING,
 DISCONNECT, AND MAIN
 PANEL

ONE LINE DIAGRAM
 NOT TO SCALE

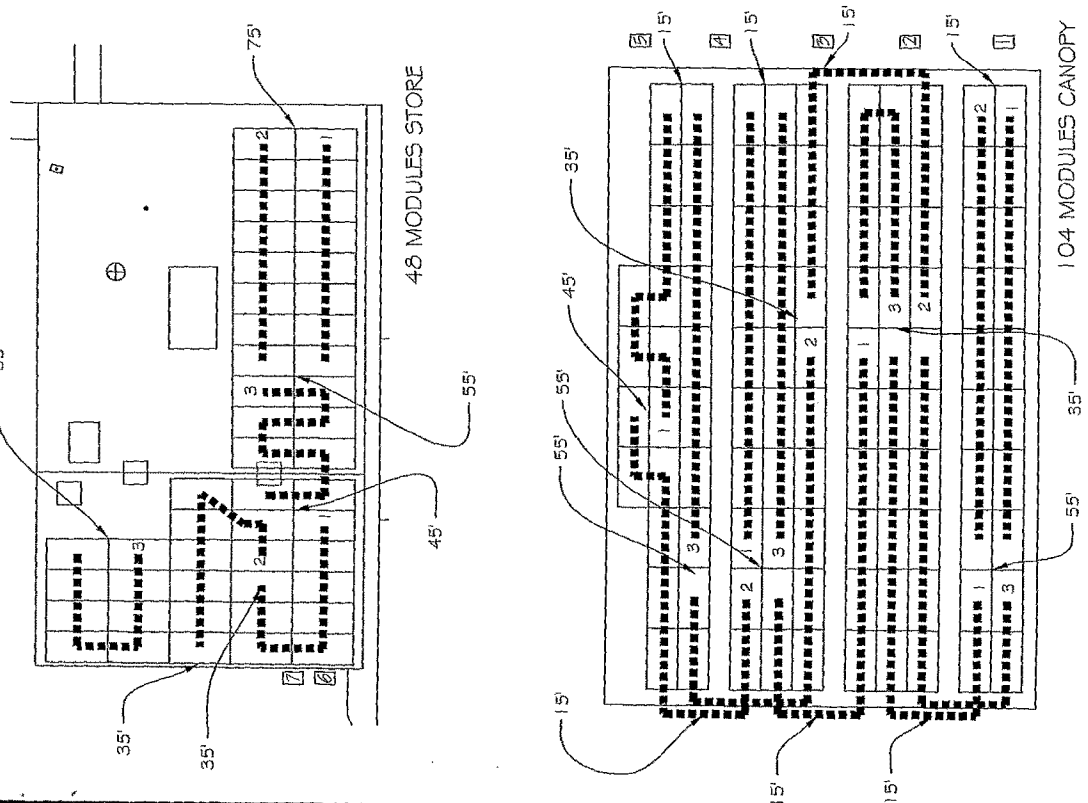

MATERIALS LIST:

HOME RUN LENGTHS	2 @ 75'
	15 @ 55'
	4 @ 45'
	12 @ 15'
COMBINER BOXES	= 7