

B

Type

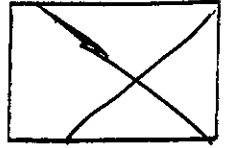

Plans

B- 132032

Permit Number

7050

Street Number

Hwy 1

Street Name

BBY

Community Code

101-130-013

APN

**NOTES**

1. ALL WORK SHALL CONFORM TO LOCAL BUILDING CODE.
2. CONCRETE: SLAB AND TANK,  $f'_c = 2,000$  PSI  $\Delta$
3. A = DIMENSION FOR 2,000 - GALLON TANK  
 B = " 4,000 - " "  
 C = " 8,000 - " "  
 D = " 10,500 - " "
4. REBAR: ASTM A615, GRADE 40. STAGGER ADJACENT HORIZONTAL SPLICES. MIN. LAP SPLICE: 20" #4, 12" #3.  $\Delta$
5. THIS PLAN IS REDUCED - SCALE EQUIVALENT OF STANDARD TANK PLAN DATED SEPTEMBER 23, 1976 FROM THIS OFFICE.

**THESE ATTACHMENTS ARE PART OF THE APPROVED PLANS.**

**\* DO NOT REMOVE THEM \***

- Plan Checklist.
- Energy Conservation Details.
- Extracts from Code Manual.
- Fire Marshal Requirements.
- Special Inspection Form.

APPROVED FOR REPRODUCTION

*Joseph W. Burton*

JOSEPH W. BURTON  
LIC. EX. 12/96

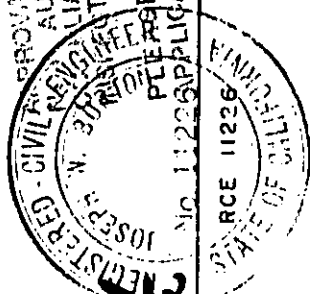

BURTON ENGINEERS  
PETALUMA

REVISED: 6-1-93  
CURRENT PRINTING DATE: 5-16-94

SEPT. 23, 1976

SHEET 1 OF 2  
DWG. 1190-1

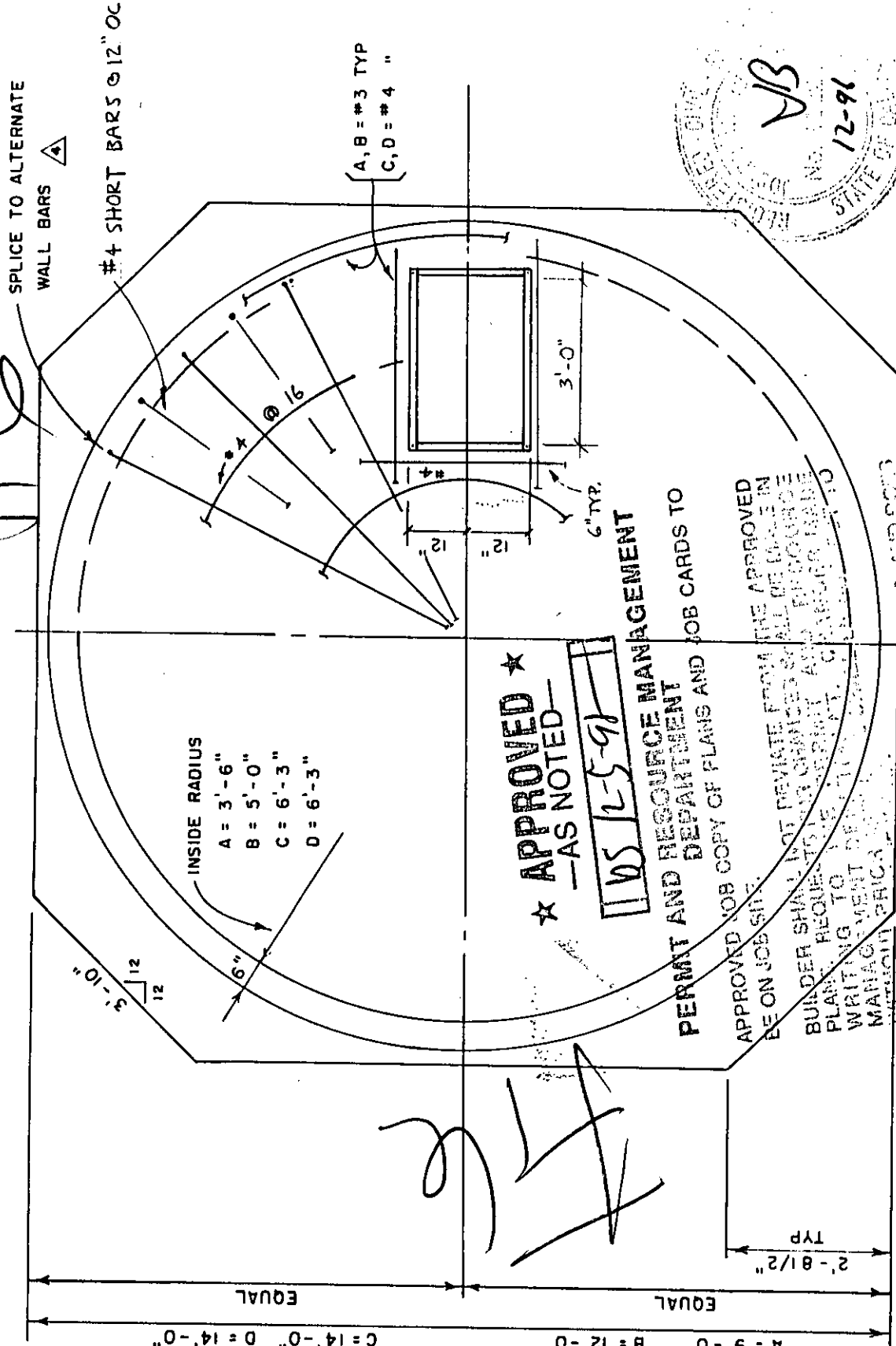

**★ APPROVED ★**  
**—AS NOTED—**

**JWB 12-5-91**

**PERMIT AND RESOURCE MANAGEMENT**  
**DEPARTMENT**

**APPROVED JOB COPY OF PLANS AND JOB CARDS TO BE ON JOB SITE.**

**BUILDER SHALL NOT DEVIATE FROM THE APPROVED PLANS. REQUIRE TO BE CHANGED SHALL BE MADE BY WRITING TO THE PERMIT AND RESOURCE MANAGEMENT DEPARTMENT. CHANGES MADE WITHOUT PRIOR APPROVAL WILL BE CONSIDERED REJECTION OF THE PLANS TO BE CONSIDERED COMPLETE.**

STANDARD 2,000 TO 10,500 GALLON CONCRETE WATER TANKS  
REQUIRED GLAZIER & GLAZIER BUILDERS, INC.

PLEASE READ ALL PERTINENT SPECIFICATIONS WHEN REQUIRED.

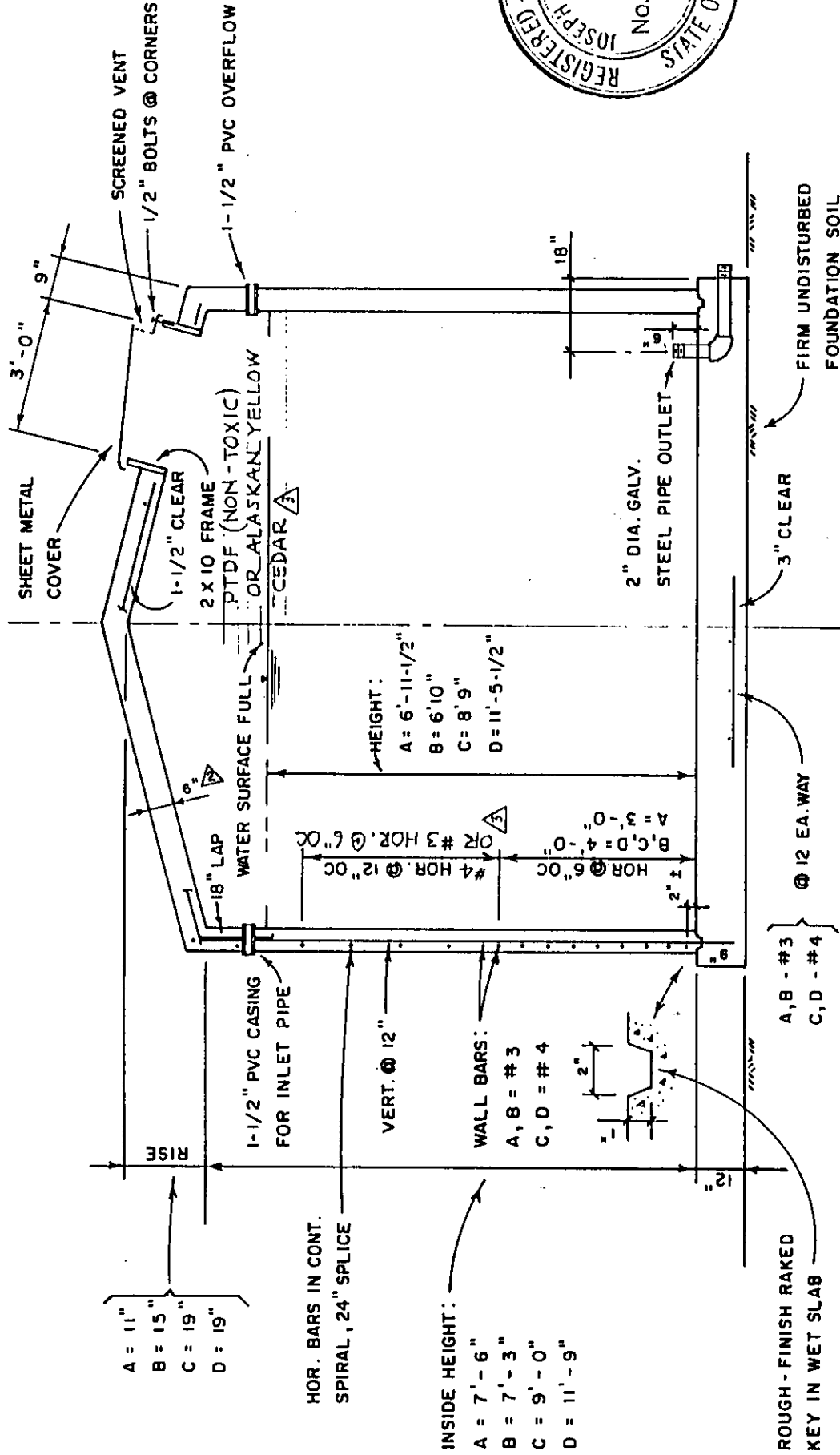
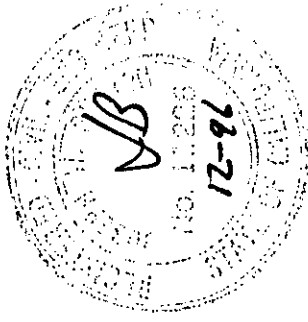

CURRENT PRINTING DATE: 5-16-94

REVISED: 6-1-93

NOTES

1. ALL WORK SHALL CONFORM TO LOCAL BUILDING CODE.
2. CONCRETE: SLAB AND TANK,  $f'_c = 2,000$  PSI  $\triangle$
3. A = DIMENSION FOR 2,000 - GALLON TANK  
 B = " " 4,000 - " "  
 C = " " 8,000 - " "  
 D = " " 10,500 - " "
4. REBAR: ASTM A615, GRADE 40. STAGGER ADJACENT HORIZONTAL SPLICES. MIN. LAP SPLICE: 20" #4, 12" #3.  $\triangle$
5. THIS PLAN IS REDUCED - SCALE EQUIVALENT OF STANDARD TANK PLAN DATED SEPTEMBER 23, 1976 FROM THIS OFFICE.

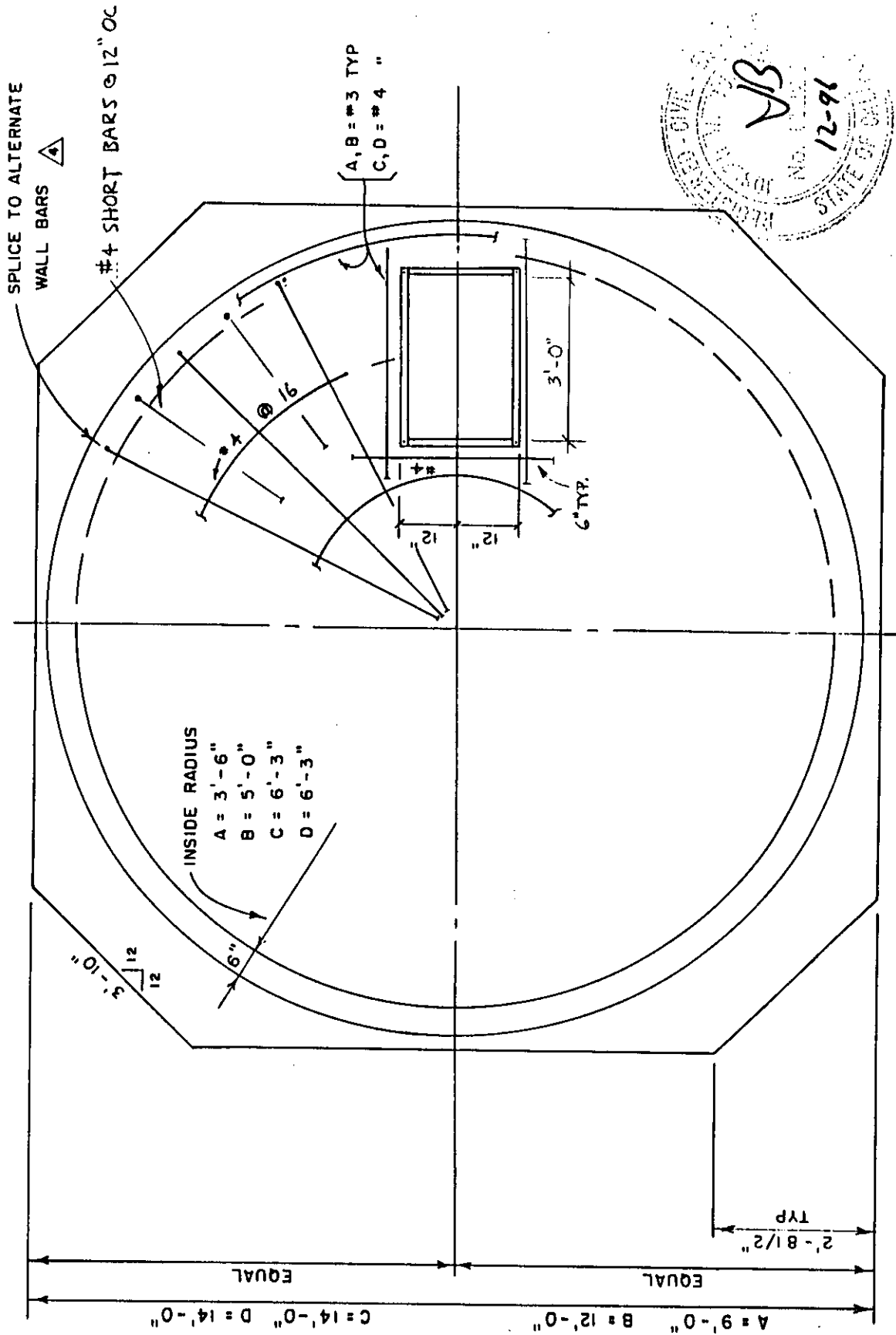

STANDARD 2,000 TO 10,500 - GALLON CONCRETE WATER TANKS  
 GLAZIER & GLAZIER BUILDERS, INC.

SEPT. 23, 1976

BURTON ENGINEERS  
 PETALUMA

REVISED: 6-1-93

CURRENT PRINTING DATE: 5-16-94

JOSEPH W. BURTON

LIC. EX. 12/96

APPROVED FOR REPRODUCTION

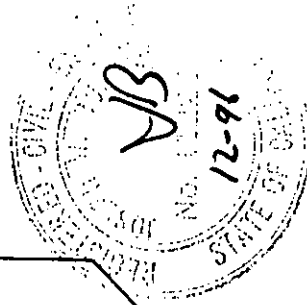
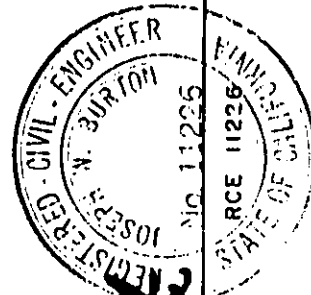



**STRUCTURAL CALCULATIONS:  
2000, 4000, 8000 and 10,500-GALLON  
CONCRETE WATER TANKS:**

**Burton Engineers**  
P.O. Box 5957  
Petaluma, CA 94955  
(707) 763-2461

Job 1190  
Sheet 1  
of 2 sheets  
10-29-91

Reprinted: 5-24-93

**ASSUMPTIONS:**

water weight, pcf: 62.4  
concrete f'c, psi: 2000  
rebar grade: 40  
max rebar tension, ksi: 20  
max keyway shear, psi: 50.5 (38 psi x 133%)

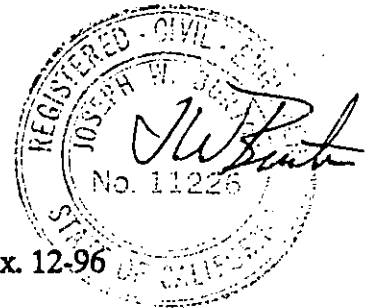

Ex. 12-96

	2000	4000	8000	10500
tank size, gallons:	2000	4000	8000	10500
diameter D, ft:	7.0	10.0	12.5	12.5
height H, ft:	6.95	6.81	8.71	11.44
bottom pressure PR, psf:	433	425	544	714
ring tension, PR*D/2, klf:	1.52	2.12	3.40	4.46
bottom bars:	#3@6	#3@6	#4@6	#4@6
area, sq.in/lf:	0.22	0.22	0.39	0.39
rebar tension, ksi:	6.87	9.62	8.65	11.36
mid-D pressure PR, psf:	217	212	272	357
ring tension, PR*D/2, klf:	0.76	1.06	1.70	2.23
middepth bars:	#3@12	#3@12	#4@12	#4@12
area, sq.in/lf:	0.11	0.11	0.20	0.20
rebar tension, ksi:	6.87	9.62	8.65	11.36
keyway area A, pi*D*2":	528	754	942	942
tank DL:				
walls, (H+1')*0.5*pi*D*150:	13.1	18.4	28.6	36.6
roof, pi/4*D^2*0.5*150:	2.9	5.9	9.2	9.2
water, pi/4*D^2*H*62.4:	16.7	33.4	66.7	87.6
total W, k:	32.7	57.7	104.5	133.4
seismic V, 0.4*1*2.75*W/6:	6.0	10.6	19.2	24.5
keyway shear, V/A, psi:	11.4	14.0	20.3	26.0

**B. ROOF SLAB CHECK, 10,500-GALLON TANK:**

Check bending in each half and tension-ring forces for center portion:

Span, ft: 6.3  
Dead load, psf: 75.0  
Live load: 20.0

Conc  $f'c = 2000$  psi      Steel  $f_y = 40000$  psi  
Factored  $w = 1.4 \times DL + 1.7 \times LL = 1.4 \times 75 + 1.7 \times 20 = 139$  plf  
Factored  $M = w \times (L)^2 / 10 = 552$  lb-ft/ft  
Dimensions: depth = 6 in; #4@18 bars;  $A_s = 0.13$  sq in  
Depth  $d = 6.0 - 1.5 - 0.50/2 = 4.25$  in  
 $Rho = A_s / bw / d = 0.0018$   
 $omega = A_s / (bw \times d) \times f_y / f'c = 0.051$   
 $au = phi \times f_y \times (1 - 0.59 \times omega) / 12000 = 2.91$   
Min.  $A_s = M / a / d = 552 / 2.91 / 4.25 / 1000 = 0.04$  sq in vs. 0.13 actual ok  
Concrete  $K_u = phi \times f'c \times omega \times (1 - 0.59 \times omega) = 89.6$   
Max concrete  $M_u = K_u \times bw \times d^2 / 12 = 1618$  lb-ft vs. 552 actual ok

6-inch concrete slab  
#4@18 bars

CENTRAL PORTION D+L

$$= \frac{\pi}{4} \times (6.3')^2 \times (75 + 20) \text{ psf}$$

$$= 2300 \text{ LB}$$

TOTAL RING TENSION

$$= 2300 \text{ LB} \times \frac{75''}{19''} = 9080 \text{ LB}$$

50% EACH HALF = 4540 LB

REBAR TENSION =  $\frac{4540}{2} = 2270 \text{ LB}$

#4 BAR GOOD FOR  $20 \text{ ksi} \times 0.20 \text{ in}^2$

$$= 4 \text{ K} > 2270 \text{ LB} \quad \text{OK}$$

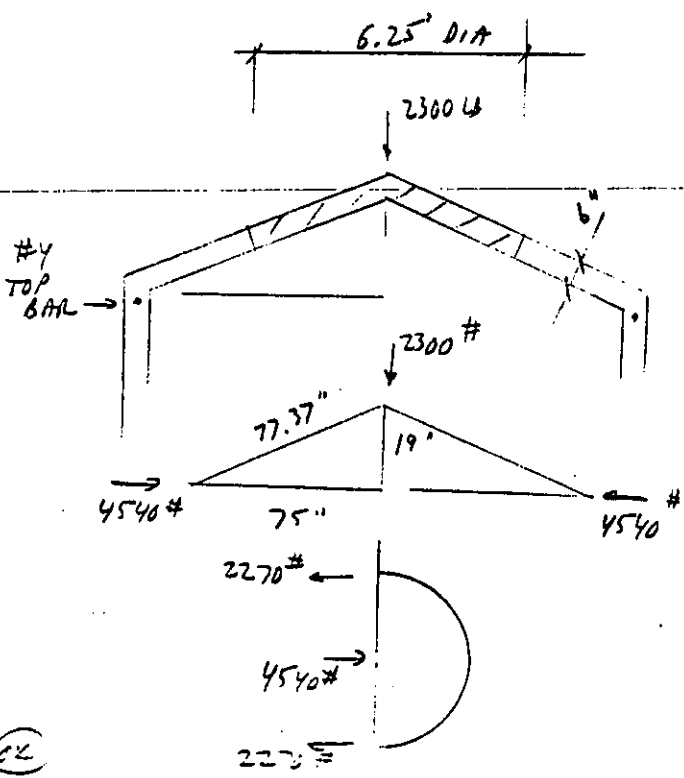



**COUNTY OF SONOMA - PERMIT AND RESOURCE MANAGEMENT DEPARTMENT**  
 2550 Ventura Avenue, Santa Rosa, CA 95403 (707) 527-1900 FAX (707) 527-1103

DL

Please Print  
 Your Name: **FRANK GLAZIER** Date Applied: **Sept. 8, 1995**

IF YOU ARE HERE FOR A PERMIT, PLEASE COMPLETE TO EXPEDITE ASSISTANCE

SITE LOCATION INFORMATION - PRINT CLEARLY																					
Site Address: <b>6700 Highway One</b>		City: <b>Bodega Bay</b>	ZIP: _____																		
Cross-Street: <b>Duncan Landing</b>		APN: <b>101-130-013</b>																			
Directions: _____																					
Describe Project: <b>Concrete water storage tank.</b>		Living Area: <b>10,500 Ga. Cap.</b>	Contract Price: <b>\$4,950.00</b>																		
Garage _____		Decks _____																			
OWNER NAME AND ADDRESS		APPLICANT NAME AND ADDRESS																			
Name: <b>West Beach Mutual Water Co.</b>		Name: <b>Frank Glazier</b>																			
Mailing Address: <b>7120 Hwy. one</b>		Mailing Address: <b>50 Fallon Rd.,</b>																			
City: <b>Bodega Bay</b>	State: <b>Ca.</b>	City: <b>Petaluma</b>	State: <b>Ca.</b>																		
ZIP: _____	Day Ph: ( ) <b>875-3052</b>	ZIP: <b>94952</b>	Day Ph: ( ) <b>763-1027</b>																		
CONTRACTOR INFORMATION		OTHER PERSONS (ARCHITECT, ENGINEER, ETC.)																			
Company Name: <b>GLAZIER &amp; GLAZIER BLDRS. INC.</b>		Name: <b>BURTON ENGINEERS</b>																			
Address: <b>50 FALLON ROAD</b>		Address: <b>24 WESTERN AVE.,</b>																			
City: <b>PETALUMA</b>	State: <b>CALIF.</b>	City: <b>PETALUMA</b>	State: <b>CA.</b>																		
ZIP: <b>94952</b>	Day Ph: ( ) <b>763-1027</b>	ZIP: _____	Day Ph: ( ) _____																		
WORKER'S COMPENSATION DECLARATION		CONSTRUCTION LENDING DECLARATION																			
I hereby affirm under penalty of perjury one of the following declarations: I have and will maintain a certificate of consent to self-insure for worker's compensation, as provided for by Section 3700 of the Labor Code, for the performance of the work for which this permit is issued.  I have and will maintain worker's compensation insurance, as required by Section 3700 of the Labor Code, for the performance of the work for which this permit is issued. My worker's compensation insurance carrier and policy number are:  Carrier: <b>CAL COMP INS CO</b> Policy NO: <b>G: 957104910</b> Expire: <b>7/96</b> (This section need not be completed if the permit is for one hundred dollars (\$100) or less). I certify that in the performance of the work for which this permit is issued, I shall not employ any person in any manner so as to become subject to the worker's compensation laws of California, and agree that if I should become subject to the worker's compensation provisions of Section 3700 of the Labor Code, I shall forthwith comply with those provisions.  Date: <b>9-8-95</b> Applicant: <i>Frank Glazier</i> WARNING: FAILURE TO SECURE WORKER'S COMPENSATION COVERAGE IS UNLAWFUL, AND SHALL SUBJECT AN EMPLOYER TO CRIMINAL PENALTIES AND CIVIL FINES UP TO ONE HUNDRED THOUSAND DOLLARS (\$100,000), IN ADDITION TO THE COST OF COMPENSATION, DAMAGES AS PROVIDED FOR IN SECTION 3706 OF THE LABOR CODE, INTEREST, AND ATTORNEYS FEES.		I hereby affirm under penalty of perjury that there is a construction lending agency for the performance of the work for which this permit is issued. (Sec. 3097, Ch. C.)  Lenders Name _____ Lenders Address _____																			
OWNER-BUILDER DECLARATION		FOR DEPARTMENT USE																			
I hereby affirm under penalty of perjury that I am exempt from the Contractor's License Law for the following reason (Sec. 7031.5, Business and Professions Code. Any city or county which requires a permit to construct, alter, improve, demolish, or repair any structure, prior to its issuance, also requires the applicant for such permit to file a signed statement that he or she is licensed pursuant to the provisions of the Contractor's License Law (Chapter 9 (commencing with Section 7000) of Division 3 of the Business and Professions Code) or that he or she is exempt therefrom and the basis for the alleged exemption. Any violation of Section 7031.5 by any applicant for a permit subjects the applicant to a civil penalty of not more than five hundred dollars (\$500.):  <input type="checkbox"/> I, as owner of the property, or my employees with wages as their sole compensation, will do the work, and the structure is not intended or offered for sale (Sec. 7044 Business and Professions Code. The Contractor's License Law does not apply to an owner of property who builds or improves thereon, and who does such work himself or herself or through his or her own employees, provided that such improvements are not intended or offered for sale. If, however, the building or improvement is sold within one year of completion, the owner-builder will have the burden of proving that he or she did not build or improve for the purpose of sale.) <input type="checkbox"/> I, as owner of the property, am exclusively contracting with licensed contractors to construct the project (Sec. 7044, Business and Professions Code. The Contractor's License Law does not apply to an owner of property who builds or improves thereon, and who contracts for such projects with a contractor(s) licensed pursuant to the Contractor's License Law.) <input type="checkbox"/> I am exempt under Sec. _____ B & P.C. for this reason _____  Date _____ Owner _____		Zoning: <b>AP-CC-B6-160/649</b> File No. <b>10248, CP 95-1003</b> Acres <b>346</b> Existing Use/Structures: <b>2 SFD, A USE</b> Proposed Use/Structure: <b>Water Storage Tanks, 10500 gallons each</b> Minimum Yard Requirements: NOTE: All parcels greater than 1 Acre are required to have a minimum 30' setback. Front * Left * Right * Back * Approval for Permit Issuance: _____ Approval for Occupancy: _____ By: <i>R. Gaud</i> Date: <b>012/4/95</b> Conditions: <i>Per approved site Plan</i> <i>Hold fund for installation of</i> <i>landscaping &amp; staff installation</i> <i>(plans on file)</i> Sewer Connection: <input checked="" type="checkbox"/> Available <input type="checkbox"/> Fees Paid Approved by: _____ Date: _____ Road Encroachment: <input type="checkbox"/> Fees Paid Approved by: _____ Date: _____ Septic System Permit/Clearance # _____ Approved by: _____ Date: _____ Flood Zone: <input type="checkbox"/> Yes <input type="checkbox"/> No 100 Year Flood Elevation: _____ Site Review _____ By: _____ Date: _____ Condition of Soil at Job Site: <input type="checkbox"/> Original <input type="checkbox"/> Engineered Fill <input type="checkbox"/> Loose Fill Required Reports: <input type="checkbox"/> Geology <input type="checkbox"/> Soils <input type="checkbox"/> Compaction Code Enforcement Violation <input type="checkbox"/> Yes <input checked="" type="checkbox"/> No Work Authorized: <i>Tom H</i> <input checked="" type="checkbox"/> New <input type="checkbox"/> Addition <input type="checkbox"/> Alteration <input type="checkbox"/> Repair <input type="checkbox"/> OccChg Report No. <b>010489</b> Date <b>12-05-95</b>																			
LICENSED CONTRACTOR'S DECLARATION		PERMIT FEES																			
I hereby affirm under penalty of perjury that I am licensed under provisions of Chapter 9 (commencing with Section 7000) of Division 3 of the Business and Professions Code, and my license is in full force and effect.  Lic. Class: <b>B</b> Lic. No. <b>373850</b>  Date <b>9/8/95</b> Contractor: <i>Frank Glazier</i>		<table border="1" style="width:100%; border-collapse: collapse;"> <tr> <td>#</td> <td>Description</td> <td>Amount</td> </tr> <tr> <td>#</td> <td>Machine Specs for Permit Fee</td> <td>\$143.20</td> </tr> <tr> <td>#</td> <td>0014320</td> <td>\$143.20</td> </tr> <tr> <td>#</td> <td>0014320</td> <td>\$143.20</td> </tr> <tr> <td>#</td> <td>CHECK</td> <td>\$143.20</td> </tr> <tr> <td>#</td> <td>CHNG</td> <td>\$0.00</td> </tr> </table>		#	Description	Amount	#	Machine Specs for Permit Fee	\$143.20	#	0014320	\$143.20	#	0014320	\$143.20	#	CHECK	\$143.20	#	CHNG	\$0.00
#	Description	Amount																			
#	Machine Specs for Permit Fee	\$143.20																			
#	0014320	\$143.20																			
#	0014320	\$143.20																			
#	CHECK	\$143.20																			
#	CHNG	\$0.00																			
I certify that I have read this application and affirm under penalty of perjury that the above information is correct. I agree to comply with all local Ordinances and State laws relating to building construction. I hereby authorize representatives of the County of Sonoma to enter upon the above-mentioned property for inspection purposes. If, after making the Certificate of Exemption for the Worker's Compensation provision of the Labor Code I should become subject to such provisions, I will forthwith comply. In the event I do not comply with the Workman's Compensation law, this permit shall be deemed revoked.  NOTICE! THIS PERMIT WILL EXPIRE BY LIMITATION IF WORK IS NOT STARTED IN 180 DAYS OR IF WORK IS ABANDONED FOR MORE THAN 180 DAYS. A REQUEST FOR TIME EXTENSION MUST BE SUBMITTED IN WRITING TO THE BUILDING CODE ADMINISTRATOR WITHIN THE FIRST 180 DAYS OF THE PERMIT.  PERMITTEE SIGNATURE: <i>Frank Glazier</i> ADDRESS: <b>50 FALLON RD. Petaluma</b> CITY: _____ ZIP: _____ <input checked="" type="checkbox"/> Contractor <input type="checkbox"/> Owner <input type="checkbox"/> Agent for Contractor <input type="checkbox"/> Agent for Owner		<table border="1" style="width:100%; border-collapse: collapse;"> <tr> <td>Type of Construction</td> <td>Occupancy</td> <td>No. of Stories</td> <td>No. of Bedrooms</td> </tr> <tr> <td>Auto Fire Sprinklers Req'd</td> <td>No. of Units</td> <td colspan="2">Certificate of Occupancy</td> </tr> <tr> <td>Final Date</td> <td colspan="3">Inspector</td> </tr> <tr> <td><b>10/4/97</b></td> <td colspan="3">_____</td> </tr> </table>		Type of Construction	Occupancy	No. of Stories	No. of Bedrooms	Auto Fire Sprinklers Req'd	No. of Units	Certificate of Occupancy		Final Date	Inspector			<b>10/4/97</b>	_____				
Type of Construction	Occupancy	No. of Stories	No. of Bedrooms																		
Auto Fire Sprinklers Req'd	No. of Units	Certificate of Occupancy																			
Final Date	Inspector																				
<b>10/4/97</b>	_____																				
Permit # <b>B-132032</b> Area <b>7</b>  Permit Coordinator <i>D. Dilucco</i>		JOB ADDRESS: <b>6700 Highway One</b> MAP REFERENCE: <b>WB3</b> PERMIT NUMBER: <b>B-132032</b> INSPECTION AREA: <b>7</b>																			

**DEPARTMENT USE ONLY - BUILDING PERMIT QUESTIONNAIRE**

Prior to issuance of a building permit, this department is required to verify that your project is consistent with regulation of other agencies. This questionnaire will assist us in informing you of those agencies you must contact and those approval you must secure prior to issuance of a building permit.

Sewage disposal for the subject building will be provided by:

- Connection to public sewer       Septic Disposal System       The proposed building contains no plumbing

Water for the subject building will be provided by:

- A private well       From the following water district       The building contains no plumbing or water system

The subject building is located in the following school district:

The subject building ( is) ( is not) ( may be) located within the Santa Rosa sphere of influence. These are the areas of anticipated future City annexations. Project within these areas are subject to City review and approval prior to building permit issuance.

Access to the property:

- Exists and will not be altered       Will be developed or altered       Access is from a public or private street

Fire protection on this property is provided by the following Fire District: \_\_\_\_\_

This property ( is) ( is not) in a State Wildfire Responsibility Area.

Is project in Northern Sonoma County Air Pollution Control District (Check Map)       YES       NO

Will the building occupants need to comply with the applicable requirements of Sections 25505, 25533 and 25534 of the Health and Safety Code and the requirements for a permit for construction or modification from the Air Quality Control District?  
 YES       NO

Written asbestos notification pursuant to Part 61 of Title 40 of the Code of Federal Regulations is required when asbestos exists in buildings, or portions thereof, undergoing demolition. I hereby declare that demolition authorized by this permit is from construction that ( does) ( does not) contain asbestos or, that no demolition is authorized by this permit.

You have submitted plans to this department for review.

**ALL CLEARANCES DESIGNATED BELOW WILL BE REQUIRED PRIOR TO ISSUANCE OF YOUR BUILDING PERMIT.**

	Clearances Required	Received		Clearances Required	Received
<b>Permit &amp; Resource Management Department</b>			<b>Parks &amp; Recreation Department</b>		
Zoning Clearance	<input type="checkbox"/>	<input type="checkbox"/>	Park Fee	<input type="checkbox"/>	<input type="checkbox"/>
Grading Permit	<input type="checkbox"/>	<input type="checkbox"/>	<b>Health Department</b>		
Geotechnical Report	<input type="checkbox"/>	<input type="checkbox"/>	Food Handling	<input type="checkbox"/>	<input type="checkbox"/>
Elevation Certificate (Flood)	<input type="checkbox"/>	<input type="checkbox"/>	<b>Special Districts (List District)</b>		
Additional Fees (Plancheck)	<input type="checkbox"/>	<input type="checkbox"/>	Water _____	<input type="checkbox"/>	<input type="checkbox"/>
Owner Builder Verification	<input type="checkbox"/>	<input type="checkbox"/>	Sewer _____	<input type="checkbox"/>	<input type="checkbox"/>
Worker's Compensation	<input type="checkbox"/>	<input type="checkbox"/>	<b>Utility Certificate</b>		
Wastewater Discharge Permit (Commercial Only) (excluding South Park)	<input type="checkbox"/>	<input type="checkbox"/>	Santa Rosa	<input type="checkbox"/>	<input type="checkbox"/>
Development Fees	<input type="checkbox"/>	<input type="checkbox"/>	Fire Marshall _____	<input type="checkbox"/>	<input type="checkbox"/>
Floor Plan For Assessor (11"x17" Maximum)	<input checked="" type="checkbox"/>	<input type="checkbox"/>	<b>Air Quality Control</b> (Asbestos Declaration AB2791)	<input type="checkbox"/>	<input type="checkbox"/>
Well & Septic	<input type="checkbox"/>	<input type="checkbox"/>	<b>School Mitigation Fee</b>	<input type="checkbox"/>	<input type="checkbox"/>
Sewer	<input type="checkbox"/>	<input type="checkbox"/>			
Road Encroachment	<input type="checkbox"/>	<input type="checkbox"/>			
Parcel Map Improvement Conditions	<input type="checkbox"/>	<input type="checkbox"/>			
Drainage	<input type="checkbox"/>	<input type="checkbox"/>			
Creek Setback	<input type="checkbox"/>	<input type="checkbox"/>			
Code Enforcement	<input type="checkbox"/>	<input type="checkbox"/>			
Investigation Fees	<input type="checkbox"/>				
(Equal to total of bldg., plmb., elec., mech. fees)					
Penalties	<input type="checkbox"/>				
(Equal to total of bldg., plmb., elec., mech. fees x _____)					

SPECIAL INSPECTION REQUIRED?

YES

NO

IF YES, SEE ADDITIONAL SHEET

INSPECTION RECORD	DATE	NAME	REMARKS
<b>FOUNDATION</b>			<i>Progress 6-5-96</i>
FORMS/SETBACK			
FOOTING			
WALLS			
<b>UNDER GROUND #</b>			
<b>CAISSONS/PIERS</b>			
<b>SLAB</b>			
<b>MASONRY</b>			
<b>RETAINING WALLS</b>			
<b>FIREPLACE</b>			
FOOTING			
HEARTH/PROTECTION			
THROAT			
<b>CHIMNEY</b>			
<b>UNDERFLOOR/SLAB</b>			
<b>U/F ELECTRICAL</b>			
<b>U/F MECHANICAL</b>			
<b>U/F PLUMBING</b>			
<b>U/F FRAMING</b>			
<b>U/F INSULATION</b>			
DIAPHRAGMS			
<b>SHEAR WALLS</b>			
<input type="checkbox"/> INTERIOR			
<input type="checkbox"/> EXTERIOR			
<b>ROOF DIAPHRAGM</b>			
<b>FLOOR DIAPHRAGM</b>			
<b>SIDING/SHEATHING</b>			
<b>HOLD DOWNS</b>			
<b>STUCCO/PLASTER/LATH</b>			
<b>CLOSE-IN</b>			
<b>ROUGH ELECTRICAL</b>			
<b>ROUGH MECHANICAL</b>			
<b>ROUGH PLUMBING</b>			
<b>ROUGH FRAME</b>			
<b>SMOKE DETECTORS</b>			
<b>INSULATION</b>			
<b>WALLBOARD</b>			
<b>STUCCO/PLASTER/SCRATCH</b>			
<b>TUB/SHOWER PAN</b>			
<b>SUSPENDED CEILING</b>			
ROUGH ELECTRICAL			
ROUGH MECHANICAL			
<b>EXISTING</b>			
STAIRS/HANDRAILS			
RAMPS			
CORRIDORS/DOORS			
<b>HANDICAP REQS.</b>			
<b>ENERGY REQS.</b>			
<b>TEMP OCCUPANCY</b>			
<b>TEMP. ELECTRIC</b>			
<b>TEMP. GAS</b>			
<b>ELEC. METER AUTH.</b>			
<b>PANEL BOARDS/SERVICE</b>			
<b>GAS METER AUTH.</b>			
<b>GAS PRESSURE TEST</b>			
HOUSE			
YARD			
<b>MANUF. HOME FOUNDATION</b>			
<b>MANUF. HOME INSTALLATION</b>			FIRE INSP. REQ'D <input type="checkbox"/> Yes <input type="checkbox"/> No
CONTINUITY			Inspected by:
STAIRS/SKIRTS			
RIDGE BOLTING			
<b>SWIMMING POOL</b>			
<b>PRE-GUNITE</b>			
<b>PRE-DECK</b>			
<b>PRE-PLASTER/FENCE</b>			CLEARANCES:
<b>GRADING FINAL</b>			FIRE
<b>ELECTRICAL FINAL</b>			HEALTH DEPT.
<b>MECHANICAL FINAL</b>			PLANNING
<b>PLUMBING FINAL</b>			SANITATION
<b>FINAL</b>			N.C.A.P.C.D.
<b>OCCUPANCY (OK TO OCCUPY)</b>			<b>PLAN RETENTION REQUIRED</b>
			Yes <input type="checkbox"/> No <input type="checkbox"/>

PERMIT # B-132031

# ***Notice of Final Action***

## ***Coastal Permit***

### **Sonoma County Permit and Resource Management Department**

2550 Ventura Avenue, Santa Rosa, CA 95403  
(707) 527-1900 FAX (707) 527-1103

---

Date: November 29, 1995

File:

CPN 95-1003 CP# 325

Applicant:

West Beach Mutual Water Co.

Address:

P.O. Box 99

City, State, Zip:

Bodega Bay, CA 94923

Planner:

Kathi Jacobs

This notice is being distributed to the Coastal Commission and those who requested notice. The following project is located within the Coastal Zone. A project decision has been completed.

Project Description: Construction of two 10,900 gallon water storage tanks and maintenance shed on 346 acres, to serve West Beach Mutual Water Company.

Project Location: 7050 Highway One, Bodega Bay

Assessor's Parcel Number: 101-130-013

X  APPROVED by the Permit and Resource Management Department on November 22, 1995.

Conditions of Approval:

See attached.

Findings:

See attached.

X  Not appealable to the Coastal Commission

*Rec'd 11-30-95  
1:30 pm*

Conditions of Approval  
CPN 95-1003 CP# 325/West Beach Mutual Water Co.  
Kathi Jacobs

Building:

1. Applicant shall obtain all applicable permits.

Health:

2. The applicant shall complete the application for an amendment to the water supply permit.

Planning:

3. Prior to issuance of the building permit, the building plans shall be revised to show a elevations and a cross-section of the tanks and shed, illustrating how they will be buried and screened from view, and indicating the color of paint to be used. Berming and planting of native vegetation may be required to achieve the required screening subject to approval by the Director of the Permit and Resource Management Department.
4. This permit shall be subject to revocation or modification by the Permit and Resource Management Department, Planning Division if: (a) the Department finds that there has been non-compliance with any of the conditions or (b) the Department finds that the use for which this permit is here by granted constitutes a nuisance. Any such revocation shall be preceded by a public hearing noticed and heard pursuant to Section 26-465.1 and 26-465.2 of the Sonoma County Code.

In any case where a zoning permit, use permit, or variance permit has not been used within two (2) years after the date of granting thereof, or for such additional period as may be specified in the permit, such permit shall become automatically void and of no further effect provided, however, that upon written request by the applicant prior to the expiration of the two year period the permit approval may be extended for not more than one (1) year by the authority which granted the original permit pursuant to Section 26-465.1 of the Sonoma County Code.

**COUNTY OF SONOMA**  
**PERMIT AND RESOURCE MANAGEMENT DEPARTMENT**  
**Planning Division**

2550 Ventura Avenue, Santa Rosa, CA 95403  
(707) 527-1900 FAX (707) 527-1103

---

October 3, 1995

William Shambaugh  
P.O. Box 52  
Bodega Bay, CA 94923

RE: CPN 95-1003

Dear Mr. Shambaugh:

Pursuant to Government Code Section 65943, the Permit and Resource Management Department, Planning Division must notify you that your application is either complete or incomplete. Your application was received on September 22, 1995 and processing has begun. However, your file is incomplete for the following reasons and additional information is needed:

1. Elevation view of tanks and shed, showing height above grade.
2. Please demonstrate how tanks will be screened, either by excavating below grade, landscaping, or both.

As soon as the above information is received, staff will evaluate the project and determine when the hearing should be set. You will be notified by mail of the date, time, and place where the meeting will be conducted to review and approve or deny your requested proposal.

If you have any further questions or want to discuss the project, please do not hesitate to call me at 527-1900.

Sincerely,

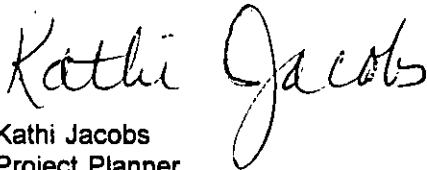

Kathi Jacobs  
Project Planner

:fmw

c: Frank Galzier  
West Beach Mutual Water Co.