

B

Type

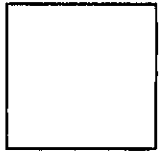

Plans

BLD16-2665

Permit Number

2419

Street Number

WEST AVE

Street Name

BEL

Community Code

043-013-038

APN

COUNTY OF SONOMA - PERMIT AND RESOURCE MANAGEMENT DEPARTMENT

2550 Ventura Avenue, Santa Rosa, CA 95403 (707) 565-1900 FAX (707) 565-1103

Please Print Your Name: Sherry Fickett Date Applied: 5/25/16

INFORMATION WITHIN HEAVY LINE TO BE COMPLETED BY APPLICANT

SITE LOCATION INFORMATION - PRINT CLEARLY

Site Address: 2419 West Ave. City: Santa Rosa ZIP: 95407

Cross-Street: _____ APN: 043013038 Project Phone #: (707) 537-5847 Project Fax #: ()

Directions: SFD Email address: _____ Unit #: _____ Lot #: _____

Describe Project: Residential solar install, 4.16 KW, roof mount, 16 panels Living Area: _____ Garage: _____ Decks: _____ Contract Price: \$16,432.00

OWNER NAME AND ADDRESS			APPLICANT NAME AND ADDRESS		
Name: <u>Margarita Flores</u>			Name: <u>Sherry Fickett</u>		
Mailing Address: <u>2419 West Ave.</u>			Mailing Address: <u>2120 March Rd. #A</u>		
City: <u>Santa Rosa</u>	State: <u>CA</u>	ZIP: <u>95407</u>	City: <u>Roseville</u>	State: <u>CA</u>	ZIP: <u>95747</u>
Day Ph: <u>(707) 537-5847</u>	Fax: ()		Day Ph: <u>(916) 757-6642</u>	Fax: ()	

CONTRACTOR INFORMATION			OTHER PERSONS (ARCHITECT, ENGINEER, ETC.)		
Company Name: <u>Syntrol Plumbing, Heating, Air</u>			Name: <u>Zachary Landes</u>		
Address: <u>2120 March Rd. #A</u>			Address: <u>same</u>		
City: <u>Roseville</u>	State: <u>CA</u>	ZIP: <u>95747</u>	City: _____	State: _____	ZIP: _____
Day Ph: <u>(916) 757-6642</u>	Fax: ()		Day Ph: ()	Fax: ()	

WORKER'S COMPENSATION DECLARATION

I hereby affirm under penalty of perjury one of the following declarations:

I have and will maintain a certificate of consent to self-insure for worker's compensation, as provided for by Section 3700 of the Labor Code, for the performance of the work for which this permit is issued.

I have and will maintain worker's compensation insurance, as required by Section 3700 of the Labor Code, for the performance of the work for which this permit is issued. My worker's compensation insurance carrier and policy number are:

Carrier: Nor Guard

Policy No: SYWC00027

(This section need not be completed if the permit is for one hundred dollars (\$100) or less.)

I certify that in the performance of the work for which this permit is issued, I shall not employ any person in any manner so as to become subject to the worker's compensation laws of California, and agree that if I should become subject to the worker's compensation provisions of Section 3700 of the Labor Code, I shall forthwith comply with those provisions.

Exp. Date: 3/1/17 Applicant: Sherry Fickett

WARNING: FAILURE TO SECURE WORKER'S COMPENSATION COVERAGE IS UNLAWFUL, AND SHALL SUBJECT AN EMPLOYER TO CRIMINAL PENALTIES AND CIVIL FINES UP TO ONE HUNDRED THOUSAND DOLLARS (\$100,000), IN ADDITION TO THE COST OF COMPENSATION, DAMAGES AS PROVIDED FOR IN SECTION 3706 OF THE LABOR CODE, INTEREST, AND ATTORNEY'S FEES.

OWNER-BUILDER DECLARATION

I hereby affirm under penalty of perjury that I am exempt from the Contractor's License Law for the following reason (Sec. 7031.5, Business and Professions Code: Any city or county which requires a permit to construct, alter, improve, demolish, or repair any structure, prior to its issuance, also requires the applicant for such permit to file a signed statement that he or she is licensed pursuant to the provisions of the Contractor's License Law (Chapter 9 (commencing with Section 7000) of Division 3 of the Business and Professions Code) or that he or she is exempt therefrom and the basis for the alleged exemption. Any violation of Section 7031.5 by any applicant for a permit subjects the applicant to a civil penalty of not more than five hundred dollars (\$500).):

I, as owner of the property, or my employees with wages as their sole compensation, will do the work, and the structure is not intended or offered for sale (Sec. 7044 Business and Professions Code: The Contractors License Law does not apply to an owner of property who builds or improves thereon, and who does such work himself or herself or through his or her own employees, provided that such improvements are not intended or offered for sale. If, however, the building or improvement is sold within one year of completion, the owner-builder will have the burden of proving that he or she did not build or improve for the purpose of sale.)

I, as owner of the property, am exclusively contracting with licensed contractors to construct the project (Sec. 7044, Business and Professions Code: The Contractors License Law does not apply to an owner of property who builds or improves thereon, and who contracts for such projects with a contractor(s) licensed pursuant to the Contractors License Law.)

I am exempt under Sec. _____, B & P.C. for this reason _____

By my signature below I acknowledge that, except for my personal residence in which I must have resided for at least one year prior to completion of the improvements covered by this permit, I cannot legally sell a structure that I have built as an owner-builder if it has not been constructed in its entirety by licensed contractors. I understand that a copy of the applicable law, Section 7044 of the Business and Professions Code, is available upon request when this application is submitted or at the following website: <http://www.leginfo.ca.gov/calaw.html>.

Date: _____ Signature of Property Owner or Authorized Agent: _____

LICENSED CONTRACTOR'S DECLARATION

I hereby affirm under penalty of perjury that I am licensed under provisions of Chapter 9 (commencing with Section 7000) of Division 3 of the Business and Professions Code, and my license is in full force and effect.

Lic. Class: C46 Lic. No.: 728304

Exp. Date: 10/31/16 Contractor: Sherry Fickett

ASBESTOS DECLARATION

Written asbestos notification pursuant to Part 61 of Title 40 of the Code of Federal Regulations is required when asbestos exists in buildings, or portions thereof, undergoing demolition. I hereby declare that demolition authorized by this permit is from construction that () does () does not contain asbestos, or that () no demolition is authorized by this permit.

I certify that I have read this application and affirm under penalty of perjury that the above information is correct. I agree to comply with all local Ordinances and State laws relating to building construction. I hereby authorize representatives of the County of Sonoma to enter upon the above-mentioned property for inspection purposes. If, after making the Certificate of Exemption for the Worker's Compensation provision of the Labor Code I should become subject to such provisions, I will forthwith comply. In the event I do not comply with the Workman's Compensation law, this permit shall be deemed revoked.

Signature: Sherry Fickett

PERMITTEE SIGNATURE

Address: 2120 March Rd. #A, Roseville, CA 95747

Contractor Owner Other Licensed Professional

CONSTRUCTION LENDING DECLARATION

I hereby affirm under penalty of perjury that there is a construction lending agency for the performance of the work for which this permit is issued. (Sec. 3097, Civ. C.)

Lenders Name: _____

Lenders Address: _____

License No: 728304 Exp. Date: 10/31/16

FOR DEPARTMENT USE

Zoning: _____ File No: _____ Acres: _____

Existing Use/Structures: _____

Proposed Use/Structures: _____

Zoning Min. Yard Requirements: Front _____ Left _____ Right _____ Back _____

NOTE: Fire Safe Standards require all parcels greater than 1 Acre to have a min. 30' setback unless mitigated. Mitigation Required Address subject to change

Approval for Permit Issuance: _____ Approval for Occupancy: _____

By: _____ Date: _____

By: _____ Date: _____

Conditions: _____

Sewer Connection: Available Fees Paid

Approved by: _____ Date: _____

Road Encroachment: Fees Paid

Approved by: _____ Date: _____

Septic System Permit/Clearance # _____

Approved by: _____ Date: _____

Flood Zone: Yes No 100 Year Flood Elevation: _____

Site Review _____

Drainage Review: _____

Approved by: _____ Date: _____

Fire: _____

Approved by: _____ Date: _____

Code Enforcement Violation Yes No Violation # _____

This permit is limited to _____ days.

Work Authorized: not mount PV system

<input checked="" type="checkbox"/> Plans Approved	<input type="checkbox"/> Post FIRM	<input type="checkbox"/> Alquist Priolo Report Available
<input type="checkbox"/> No Plans Subject to Field Inspection	<input type="checkbox"/> Pre FIRM	<input type="checkbox"/> Geotechnical report Available
Plancheck Cleared By: <u>[Signature]</u> Date: <u>5/25/16</u>	Type of Construction: <u>VB R3</u>	Occupancy: <u>R3</u> No. of Stories: _____ No. of Bedrooms: _____
Permit Cleared for Issuance By: <u>[Signature]</u> Date: <u>5/25/16</u>	Auto Fire Sprinklers Req'd: _____	No. of Units: _____ Certificate of Occupancy: _____

Payment Space for Permit Fee

PAYMENT REC'D

\$ DAF

MAY 25 2016

PERMIT AND RESOURCE MANAGEMENT DEPARTMENT
COUNTY OF SONOMA

JOB ADDRESS: 2419 West Ave PERMIT NUMBER: RD16-2605 INSPECTION AREA: 3

THIS PERMIT SHALL EXPIRE IN THREE(3) YEARS FROM DATE FEES ARE PAID UNLESS OTHERWISE NOTED BY CODE ENFORCEMENT

Distribution: White - File - Copy - Applicant - Bus - Stock - Cardstock - Inspector

131) SPECIAL INSPECTION REQUIRED		<input type="checkbox"/> YES	<input type="checkbox"/> NO	IF YES, SEE ADDITIONAL SHEET	
INSPECTION RECORD		DATE	NAME	REMARKS	
101)	ROUGH GRADING				
103)	FOUNDATION				
	FORMS/SETBACK				
	FOOTING				
	WALLS				
106)	UFER GROUND #				
104)	CAISSONS/PIERS				
105)	SLAB				
107)	UNDERGROUND UTILITIES				
110)	MASONRY				
109)	RETAINING WALLS				
113)	FIREPLACE				
	FOOTING				
	HEARTH/PROTECTION				
	THROAT				
114)	CHIMNEY				
120)	UNDERFLOOR/UNDERSLAB				
115)	HYDRONICS				
116)	U/F ELECTRICAL				
117)	U/F MECHANICAL				
118)	U/F PLUMBING				
119)	U/F FRAMING				
139)	U/F INSULATION				
126)	SHEAR WALLS				
	<input type="checkbox"/> INTERIOR		<input type="checkbox"/> EXTERIOR		
127)	DIAPHRAGMS				
	<input type="checkbox"/> ROOF		<input type="checkbox"/> FLOOR		
134)	SIDING/SHEATHING				
125)	HOLD DOWNS				
132)	CLOSE-IN				
122)	ROUGH ELECTRICAL				
123)	ROUGH MECHANICAL				
124)	ROUGH PLUMBING				
128)	ROUGH FRAME				
160)	SMOKE DETECTORS				
139)	INSULATION				
142)	WALLBOARD				
143)	FIREWALLS				
135)	STUCCO/PLASTER				
	<input type="checkbox"/> LATH		<input type="checkbox"/> SCRATCH		
137)	ROOFING				
130)	TUB/SHOWER PAN				
162)	FIRE DAMPERS/DOORS				
164)	SUSPENDED CEILING				
	<input type="checkbox"/> ROUGH ELEC.		<input type="checkbox"/> ROUGH MECH.		
165)	EXITING - RAMPS/STAIRS				
163)	HANDRAILS/GUARDRAILS				
	CORRIDORS/DOORS				
166)	ACCESSIBILITY COMPLIANCE			650)	SUSMP INSPECTION
144)	WATER TANKS			651)	NPDES EROSION COMPLIANCE
	<input type="checkbox"/> SLAB		<input type="checkbox"/> WALLS	652)	NPDES SEDIMENT COMPLIANCE
170)	TEMPORARY OCCUPANCY			653)	NPDES DOCS/SWPPP
171)	TEMPORARY ELECTRICAL				FIRE INSPECTION REQUIRED
172)	TEMPORARY GAS				<input type="checkbox"/> Yes <input type="checkbox"/> No
174)	ELECTRIC METER AUTHORIZATION			759)	KNOX BOX
152)	PANEL BOARDS/SERVICE			760)	PROPANE TANK HOLD DOWNS
189)	SEPTIC ELECTRIC FINAL			770)	SPRINKLER FINAL
175)	GAS METER AUTHORIZATION			771)	ABOVEGROUND HYDROSTATIC
153)	GAS PRESSURE TEST			772)	UNDERGROUND HYDROSTATIC
	HOUSE		YARD	773)	UNDERGROUND FLUSH
190)	MANUF. HOME FOUNDATION			774)	THRUST BLOCKS
191)	MANUF. HOME INSTALLATION			775)	PIPE WELD
	CONTINUITY			776)	HYDRANTS/APPLIANCES
	STAIRS/SKIRTS			777)	PUMP ACCEPTANCE
	RIDGE BOLTING			778)	WATER SUPPLY/TANK
193)	MANUF. HOME COND. FINAL			779)	ALARM SYSTEM
	SWIMMING POOLS			780)	HOOD & DUCT SYSTEM
194)	PRE-GUNITE			781)	ABOVEGROUND TANK/DISPENSER
195)	PRE-DECK			198)	FIRE FINAL
196)	PRE-PLASTER/FENCE				CLEARANCES:
197)	VINYL/FIBERGLASS POOL EXCAVATION				FIRE <input type="checkbox"/> Local <input type="checkbox"/> County
102)	GRADING FINAL				HEALTH DEPARTMENT
176)	ELECTRICAL FINAL				ZONING
177)	MECHANICAL FINAL				SANITATION
178)	PLUMBING FINAL				
199)	FINAL	6-28-16	JLT		PLAN RETENTION REQUIRED?
	OCCUPANCY (OK TO OCCUPY)				<input type="checkbox"/> Yes <input type="checkbox"/> No

PERMIT # B016-2685

Smoke/CO Alarm Self Verification Form

CNI-037

Building Permit # BDLH - 2665

Dear Property Owner:

The California Residential Code (CRC) requires carbon monoxide alarms (CO alarms) in dwellings as well as smoke alarms when building permits are issued and the scope of work exceeds a total cost or calculated valuation of \$1,000. In order to grant a final approval on your permit, it is necessary to verify the installation of these alarms within your dwelling. This form provides the ability to self-verify to PRMD when work done does not allow convenient access to the interior of the dwelling (e.g., re-roof or other exterior work).

As of January 1, 2014, all new and replacement battery operated smoke alarms must be equipped with a non-replaceable, non-removable battery capable of powering the alarm for 10 years. All existing smoke alarms shall be replaced after 10 years from the date of manufacture or if the date of manufacture cannot be determined.

By signing this document, the property owner certifies to PRMD that both smoke alarms and CO alarms have been installed on the above referenced project as specified below:

Smoke alarms are installed in accordance with the approved manufacturer's instructions in all of the following areas:

- a. Each sleeping unit
- b. In hallways of areas giving access to the sleeping units
- c. On each floor, if a multi-story
- d. In the basement, if a basement exists

Carbon Monoxide alarms are installed in accordance with the approved manufacturer's instructions in all of the following areas where fossil fuel burning appliances are installed, including fireplaces:

- a. Outside of each separate dwelling unit sleeping area in the immediate vicinity of the bedrooms(s).
- b. On every floor level of dwelling unit, including basements.

Please fill in the permit number above and the requested information below and return the form by mail to the Sonoma County Permit and Resource Management Department, Building & Safety Division, 2550 Ventura Avenue, Santa Rosa, CA 95403. Alternatively, this form may be submitted to the building inspector at the time the final inspection is performed.

Margarita Flores
Property Owner's Name

Signature

6-28-16
Date

2419 West Ave, SANTA ROSA 95407
Project Address

Inspector

Sonoma County Permit and Resource Management Department

2550 Ventura Avenue, Santa Rosa, CA 95403-2829 (707) 565-1900 Fax (707) 565-1972

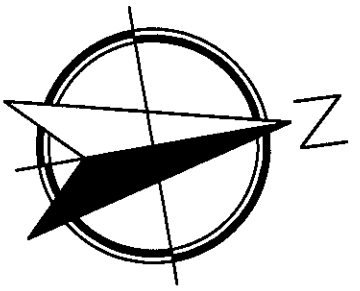

GENERAL COMPONENTS / KEY :

1. 4:12, 23° ROOF PITCH
2. 2X4 DF TRUSS AT 24" O.C.
3. ASPHALT COMP ROOF
4. (16) SILFAB SBA260-P PV MODULES
5. 16 M215 60 2LL S22 IG MICRO INVERTERS
6. IRONRIDGE FLASHFOOT FLASHING
7. IRONRIDGE XR-10 RACKING
8. WEEB CLAMPS & LUGS FOR PV GROUNDING

SYMBOL	DESCRIPTION
<input checked="" type="checkbox"/>	NEMA 4R JBOX
<input type="checkbox"/>	ROOF VENT
<input type="checkbox"/>	EMT CONDUIT
<input type="checkbox"/>	M215 60 2LL S22 IG MICRO INVERTERS
<input type="checkbox"/>	PV MODULE
<input type="checkbox"/>	FIRE FIGHTER ACCESS (CFC)(R331.2.1)
<input type="checkbox"/>	F.F.A.



3120 MARCH RD. #A, ROSEVILLE, CA 95747 - PH: (916) 775-8813 - LIC. # 72894 - www.syntrol.net

FLORES RESIDENCE
 2419 WEST AVE
 SANTA ROSA 95407
 4.16 KW DC
 APN: 043013038

WEST AVE
 BUILDING PLAN CHECK
 APPROVED
 MAY 25 2016
 PERMIT AND RESURFACING DEPARTMENT
 CE SOLAR
 LAYOUT

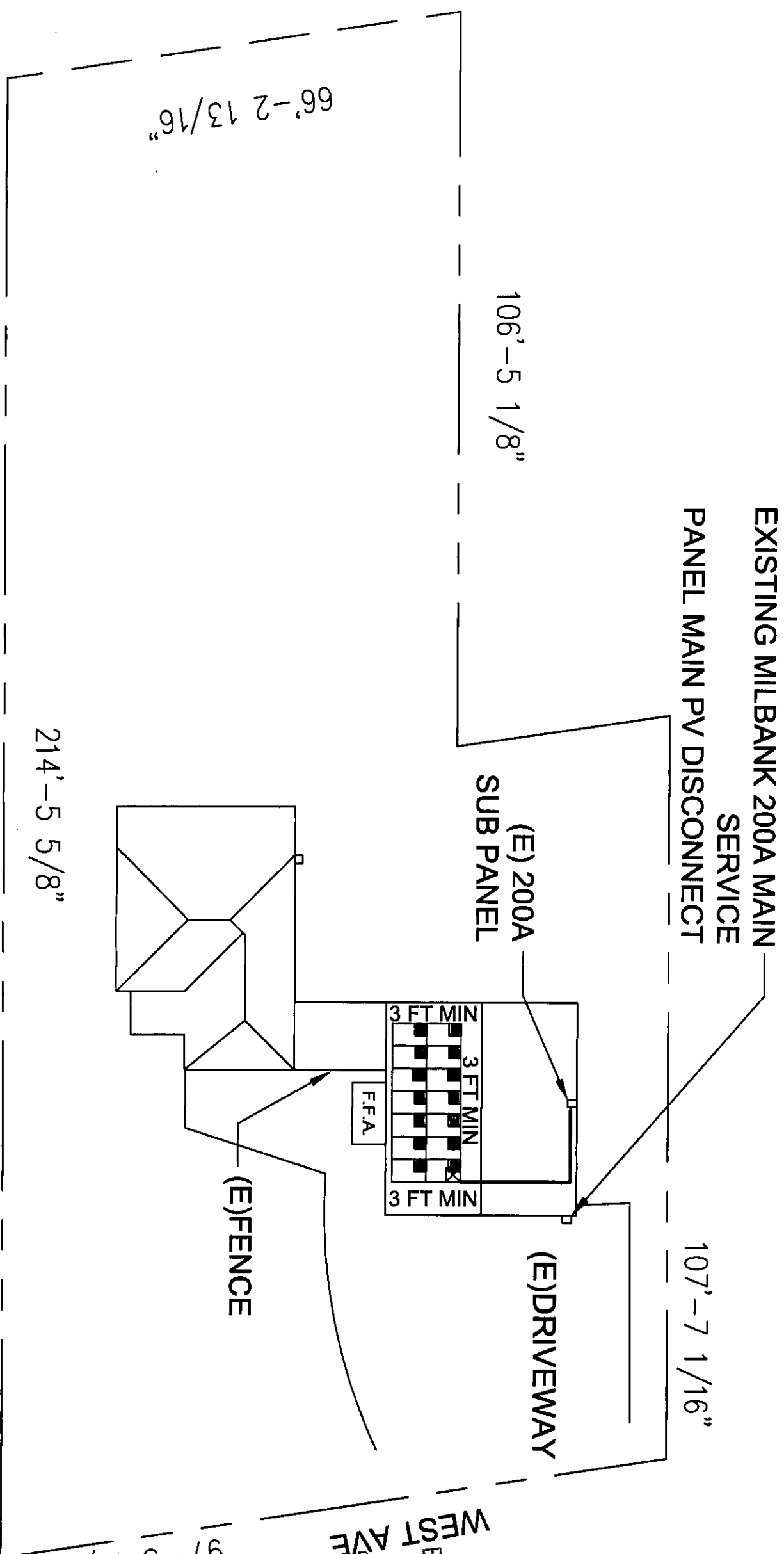

SITE PLAN

SCALE: CUSTOM

REV	DATE	DESCRIPTION
1	5/23/16	DESCRIPTION 1
2	DY/MT/YEAR	DESCRIPTION 2
3	DY/MT/YEAR	DESCRIPTION 3

DATE: 5/23/2016
 SCALE: CUSTOM
 SHEET: PV-2

UTILITY: PG&E MSP- EXISTING
 FEED LOCATION: BOTTOM FED
 MSP BRAND: MILBANK
 ROOF TYPE: ASPHALT COMP
 RACKING: IRONRIDGE XR-10
 ATTACHMENT: FLASHFOOT FLASHING
 ATTACHMENT SPACING: 72" ON CENTER

PROJECT DATA

PROJECT ADDRESS: 2419 WEST AVE
 SANTA ROSA 95407

OWNER:
 MARGARITA FLORES
 2419 WEST AVE
 SANTA ROSA 95407
 707-537-5847

CONTRACTOR:
 SYNTROL SOLAR
 2120 MARCH RD. #A
 ROSEVILLE, CA 95747
 LICENSE # 728304
 PH. (916) 772-5813

DESIGNER:
 ZACHARY LANDES
 SYNTROL SOLAR
 2120 MARCH RD. #A
 ROSEVILLE, CA 95747
 LICENSE # 728304
 PH. 9167576665

SCOPE:
 INSTALL 4.16 KW DC ROOF
 MOUNT SOLAR SYSTEM
 WITH 16 SILFAB SBA260-P PV
 MODULES AND 16 M215 60 2LL S22
 IG MICRO INVERTERS

APN: 043013038
 LOT AREA: 4 ACRES
 LIVING AREA: 1025 SQ. FT.

PV SYSTEM SUMMARY

SYSTEM SIZE:	4.16 KW DC
AREA OF INSTALLATION:	281.35 SQ. FT.
SOLAR MODULES:	SILFAB SBA260-P
TOTAL MODULE QTY.:	16

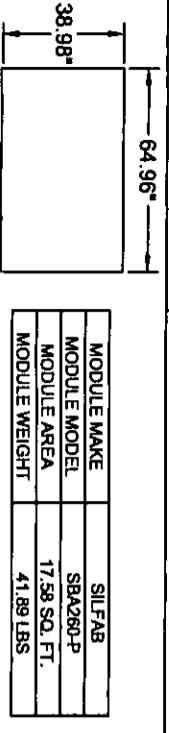

*C-10 SIGNATURE (IF NEEDED):

PROPOSED ARRAY LOCATION

ARRAY	ORIENTATION	TILT	MODULE QTY.	AREA	INVERTER MAKE & MODEL
1	173°	23°	16	281.35 SQ. FT.	M215 60 2LL S22 IG MICRO INVERTERS
2					
3					
4					

FILE COPY
Bldg. 2016
 DING PLAN CHECK
 APPROVED
 MAY 25 2016
 PERMIT AND RESOURCE
 MANAGEMENT DEPARTMENT

VICINITY MAP

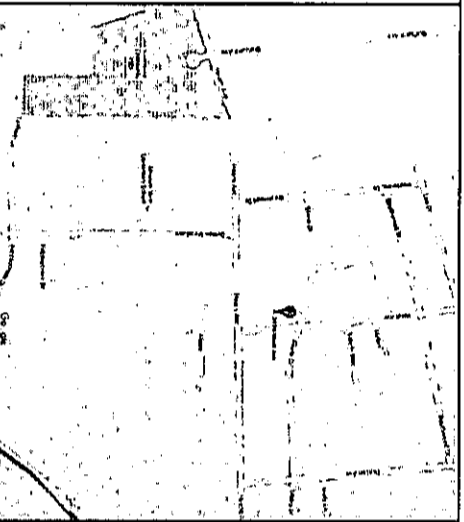

PARCEL OUTLINE



GENERAL NOTES

- ALL COMPONENTS ARE UL LISTED AND CEC CERTIFIED, WHERE WARRANTED.
- THE SOLAR PV SYSTEM WILL BE INSTALLED IN ACCORDANCE WITH ARTICLE 690 OF THE 2013 CEC AND 2013 CBC.
- WHERE METALLIC CONDUIT CONTAINING DC CONDUCTORS IS USED INSIDE THE BUILDING, IT SHALL BE IDENTIFIED AS "CAUTION: SOLAR CIRCUIT" EVERY 5 FT.
- A DC DISCONNECTING MEANS SHALL BE INSTALLED AT A READILY ACCESSIBLE LOCATION EITHER OUTSIDE OF THE BUILDING OR STRUCTURE OR INSIDE NEAREST POINT OF ENTRANCE OF THE SYSTEM CONDUCTORS AS PER SECTION 690.14 OF THE CEC.
- HEIGHT OF THE INTEGRATED AC/DC DISCONNECT SHALL NOT EXCEED 6'-7" PER NEC CODE 240.24.
- A GROUNDING ELECTRODE SYSTEM IN ACCORDANCE WITH CEC 690.47 AND 250.50 THROUGH 60 AND 250-166 SHALL BE PROVIDED. PER CEC GROUNDING ELECTRODE SYSTEM OF EXISTING BUILDING MAY BE USED AND BONDED TO THE SERVICE ENTRANCE. IF EXISTING SYSTEM IS INACCESSIBLE OR INADEQUATE A SUPPLEMENTAL GROUNDING ELECTRODE WILL BE USED AT THE INVERTER LOCATION CONSISTING OF A UL LISTED 8 FT. GROUND ROD WITH ACCORN CLAMP. GROUNDING ELECTRODE CONDUCTORS SHALL BE NO LESS THAN #8 AWG AND NO LARGER THAN #8 AWG COPPER AND BONDED TO THE EXISTING GROUNDING ELECTRODE TO PROVIDE FOR A COMPLETE SYSTEM.
- PHOTOVOLTAIC MODULES ARE TO BE CONSIDERED NON-COMBUSTIBLE.
- PHOTOVOLTAIC INSTALLATION WILL NOT OBSTRUCT ANY PLUMBING, MECHANICAL, OR BUILDING ROOF VENTS.
- THE SMOKE ALARMS SHALL BE INSTALLED OR VERIFY TO ENSURE THE SMOKE ALARMS ALREADY EXISTING WHEN ALTERATION OR REPAIR TO GROUP R-3 OCCUPANCY EXCEEDS \$1,000 CRC R314.6.
- ON THE CEILING OR WALLS OUTSIDE OF EACH SEPARATE SLEEPING AREA IN THE IMMEDIATE VICINITY OF BEDROOMS
- IN EACH ROOM USED FOR SLEEPING PURPOSES.
- IN EACH STORY WITHIN A DWELLING UNIT, INCLUDING BASEMENTS BUT NOT INCLUDING CRAWL SPACES AND UNINHABITABLE ATTICS.
- ALL SMOKE ALARMS SHALL BE LISTED IN ACCORDANCE WITH UL 217 AND INSTALLED IN ACCORDANCE WITH THE PROVISIONS OF THIS CODE AND THE HOUSEHOLD FIRE WARNING EQUIPMENT PROVISIONS OF NFPA 72. SYSTEMS AND COMPONENTS SHALL BE CALIFORNIA STATE FIRE MARSHAL LISTED AND APPROVED IN ACCORDANCE WITH CA CODE OF REGULATIONS, TITLE 19, DIVISION 1 FOR PURPOSE FOR WHICH THEY ARE INSTALLED.
- CARBON MONOXIDE ALARMS IF NOT ALREADY EXISTING ARE REQUIRED TO BE INSTALLED WITHIN A DWELLING WHEN THE VALUATION OF AN ADDITION, ALTERATION OR REPAIR TO GROUP R-3 OCCUPANCY EXCEEDS \$1,000 CRC R315.2
- CARBON MONOXIDE ALARMS ARE REQUIRED AT THE FOLLOWING LOCATIONS:
 - ON THE CEILING OR WALLS OUTSIDE OF EACH SEPARATE SLEEPING AREA IN THE IMMEDIATE VICINITY OF BEDROOMS
 - ON EACH STORY WITHIN A DWELLING UNIT, INCLUDING BASEMENTS.
 - THE CARBON MONOXIDE ALARMS SHALL BE LISTED AS COMPLYING WITH THE REQUIREMENTS OF UL 2034. CARBON MONOXIDE DETECTORS SHALL BE INSTALLED IN ACCORDANCE WITH THIS CODE. THE CURRENT EDITION OF NFPA 720 "STANDARD FOR THE INSTALLATION OF CARBON MONOXIDE (CO) DETECTION AND WARNING EQUIPMENT" AND THE MANUFACTURERS INSTALLATION INSTRUCTIONS PER 2013 CRC SECTION R315.3.

SHEET INDEX

PV-1:	GENERAL INFORMATION
PV-2:	SITE PLAN
PV-3:	FRAMING PLAN
PV-4:	SINGLE LINE DIAGRAM
PV-5:	SIGNAGE SCHEDULE
PV-6:	ELECTRICAL NOTES
PAN:	SOLAR PANEL C.S.
INV:	INVERTER C.S.
OPT:	OPTIMIZER C.S. (IF NEEDED)
RAIL:	RAILING CUTSHEETS C.S.
MNT/ENG:	MOUNTING/ENG LETTER
MAP:	QR CODES (INTERNAL USE)

CODE REFERENCES

PROJECT SHALL COMPLY WITH THE FOLLOWING APPLICABLE CODES:
 CALIFORNIA CODE OF REGULATIONS, TITLE 24
 2013 CALIFORNIA BUILDING CODE (CBC)
 2013 CALIFORNIA MECHANICAL CODE (CMC)
 2013 CALIFORNIA PLUMBING CODE (CPC)
 2013 CALIFORNIA ELECTRICAL CODE (CEC)
 2013 CALIFORNIA ENERGY CODE
 2013 CALIFORNIA FIRE CODE
 INSTALLATION TO COMPLY WITH ARTICLE 690 OF THE 2013 NATIONAL ELECTRICAL CODE (NEC)

FLORES RESIDENCE
 2419 WEST AVE
 SANTA ROSA 95407
 4.16 KWDC
 APN: 043013038



GENERAL INFORMATION

REV	DATE	DESCRIPTION
1	5/23/16	DESCRIPTION 1
2	DY/MT/YEAR	DESCRIPTION 2
3	DY/MT/YEAR	DESCRIPTION 3

DRAWN BY: ZACHARY LANDES MK
 REVIEWED: [Signature]
 DESIGNER SIGNATURE: [Signature]
 DATE: 5/23/2016
 SCALE: -
 SHEET: PV-1

Load Calculations

Job Name	FLORES RESIDENCE	
Site Address	2419 WEST AVE SANTA ROSA, CA 95407	
System Size	SILFAB POLY	4.16 KW DC
Manufacturer	SBA260-P	
Module	modules in array	16
Wattage	Module weight - lbs.	41.89
	total Module weight	670.24
	RACKING lbs./module	1
	total racking weight - lbs.	16.00
	Total ARRAY weight	686.24
	module area	17.58
	total array area	281.35
	Lbs. / Sq.Ft. (less than 5 - OK)	2.44
	number of vertical supports	0
	Lbs. per support (less than 45 - OK)	#DN/01

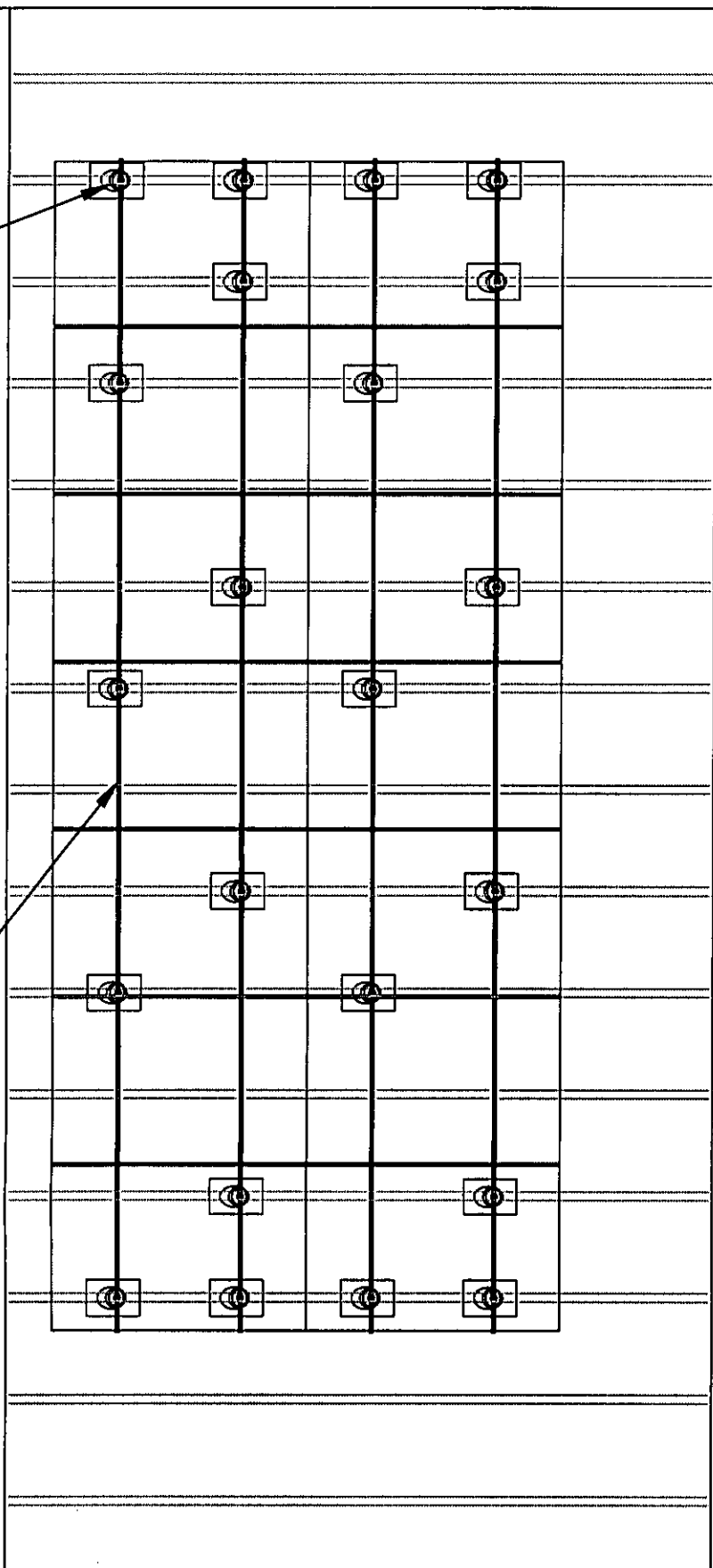

FRAMING PLAN

IRONRIDGE
FLASHFOOT FLASHING
(TYPICAL)

IRONRIDGE XR-10
RAIL (TYPICAL)

SCALE: 39/128" = 1'-0"
AS PER FIELD CONDITIONS, ROOFING
ATTACHMENTS MAY CHANGE BASED
ON LOCATION BUT NO GREATER THAN
(TYPICAL) INSTALLATION METHOD TO FOLLOW MANUFACTURE SPECIFICATIONS (TYPICAL)

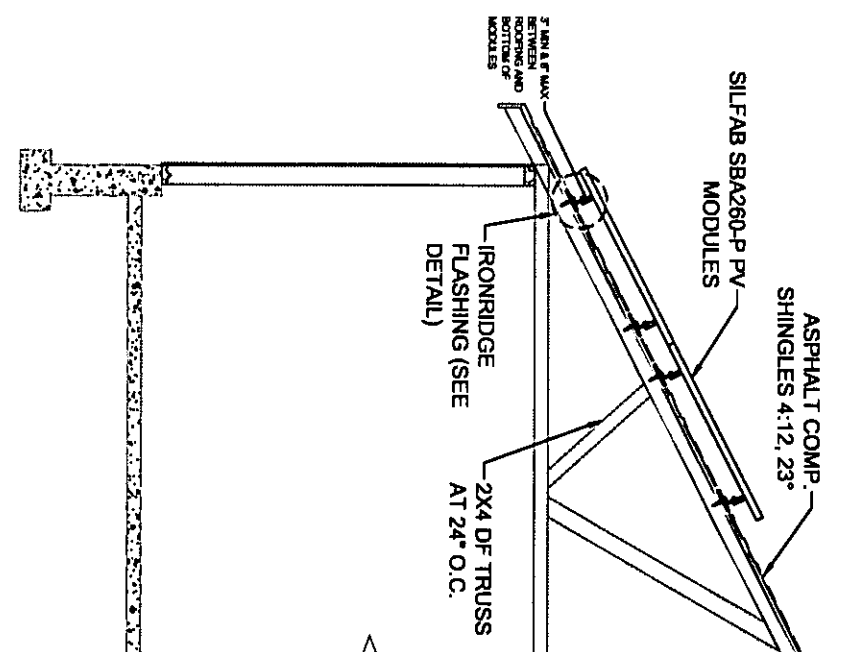

FRAMING CROSS SECTION

SCALE: N.T.S. PER PLAN CHECK
BUILDING PLAN CHECK

APPROVED

MAY 25 2016

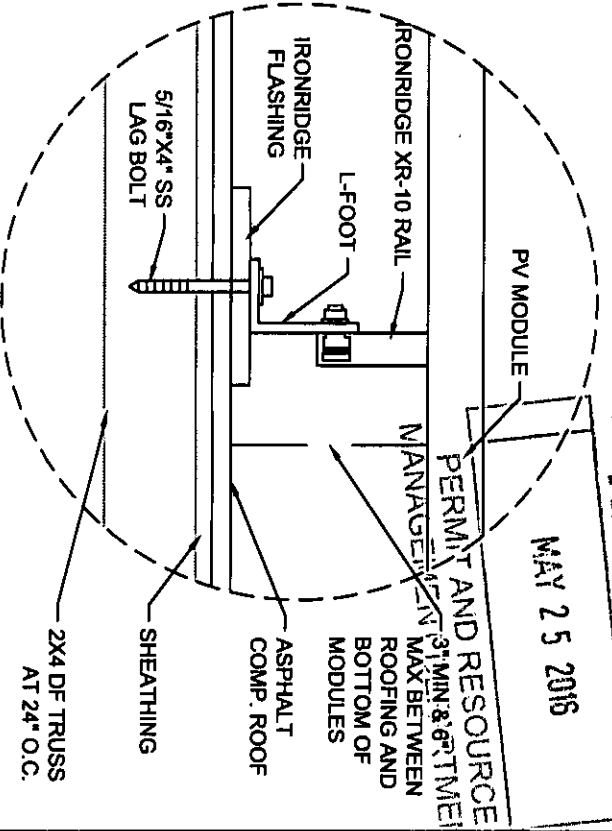

MOUNTING DETAIL

SCALE: N.T.S.

REV	DATE	DESCRIPTION
1	5/23/16	DESCRIPTION 1
2	DY/MY/EAR	DESCRIPTION 2
3	DY/MY/EAR	DESCRIPTION 3

DATE: 5/23/2016
SCALE: 39/128" = 1'-0"
SHEET: PV-3

FLORES RESIDENCE
2419 WEST AVE
SANTA ROSA 95407
4.16 KW DC
APN: 043013038



2130 MARCH RD. #A, ROBEVILLE, CA 95747 - PH. (916) 772-8813 - LIC. # 728204 - www.syntrol.com

MAIN SERVICE BUSS RATING: EXISTING MILBANK 200A 240VAC MAIN SERVICE CONTINUOUS MAX RATING 200 X 1.2 (120%) = 240A 240 - 200 (MAIN BREAKER) = 40AMPS AVAILABLE FOR SOLAR 200A SUB PANEL 20A BREAKER OKAY	ENPHASE M215 60 2LL S22 IG MICRO INVERTER RATINGS: NOMINAL OUTPUT: MAX 1.0A 215 WATTS (PER UNIT) 1.0 X 1 BRANCH CIRCUIT OF 16 = 16,00A AC 16.00 A X 1.25 = 20,00A 20A BREAKER 20A BREAKER	MAX SYSTEM VOLTAGE ENPHASE: 240V AC	MAX SYSTEM WATTAGE ENPHASE: 16 MICRO INVERTERS X 215W = 3440W	ENPHASE TRUNK CABLE INCLUDES #12 GROUND ALL UFER GROUNDS NEED IRREVERSIBLE GROUND CRIMP.		
TAG #	CONDUIT:	WIRE QTY	GAUGE:	TYPE:	GROUND GAUGE:	GROUND WIRE TYPE:
1	3" EMT	3	#10 AWG	THHN, THWN-2	#8 AWG	THHN, THWN-2
2	TRUNK		#12 AWG	ENGAGE CABLE	#8 AWG	THHN, THWN-2
E				EXISTING WIRE		

SINGLE LINE DIAGRAM

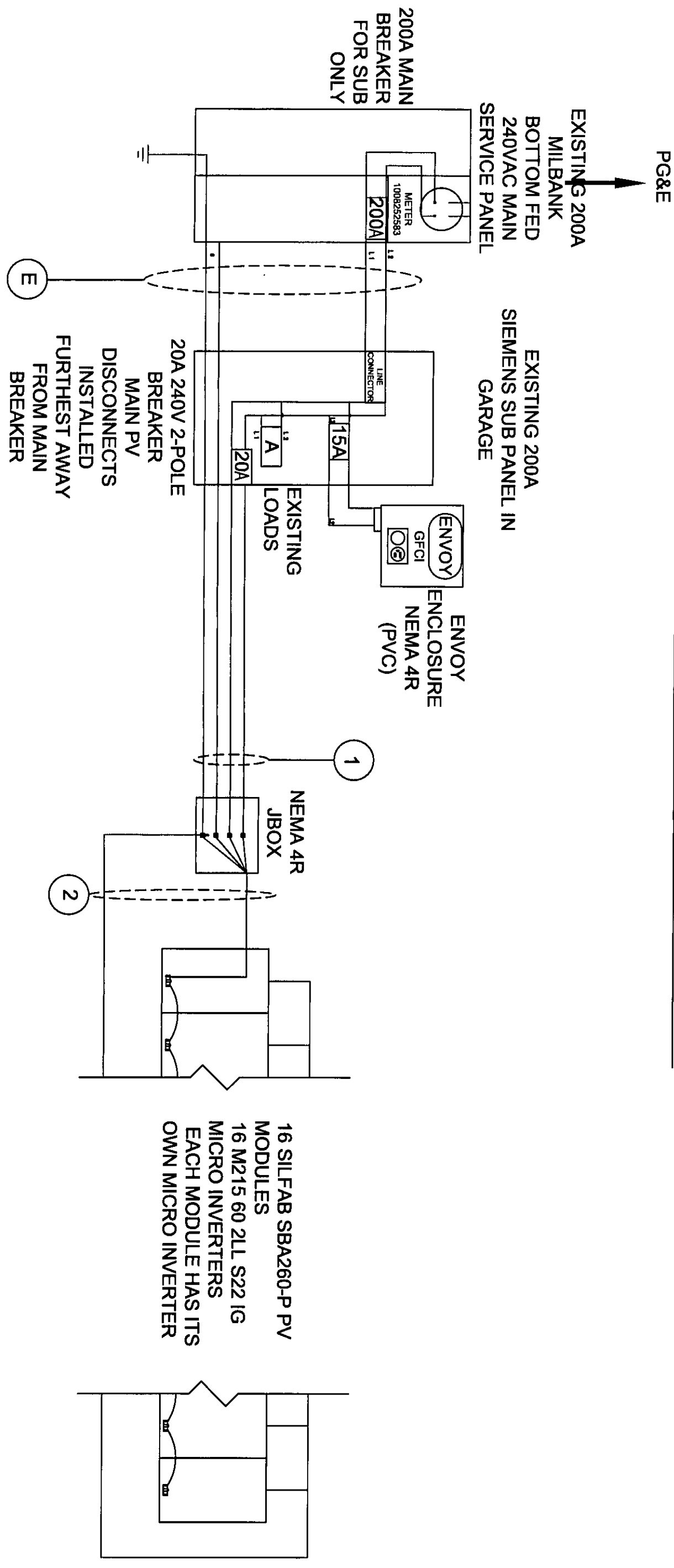

FLORES RESIDENCE
2419 WEST AVE
SANTA ROSA 95407
4.16 KW DC
APN: 043013038

Syntrol SOLAR

3120 MARCH RD. SA. REDLEVILLE, CA 95747 - PH. (916) 772-6812 - LIC. # 722804 - WWW.SYNTROL.COM

REV	DATE	DESCRIPTION
1	5/23/16	DESCRIPTION 1
2	DY/MT/YEAR	DESCRIPTION 2
3	DY/MT/YEAR	DESCRIPTION 3

SINGLE LINE DIAGRAM

DATE: 5/23/2016
SCALE: N.T.S.
SHEET: PV-4

"ELECTRICAL SERVICE PANEL"
TO BE PERMANENTLY MARKED
AS FOLLOWS:

WARNING

DUAL POWER SUPPLY
PHOTOVOLTAIC SYSTEM

"TO BE LOCATED ON EXTERIOR OF
MAIN ELECTRICAL PANEL"

"AC DISCONNECT"
TO BE PERMANENTLY MARKED
AS FOLLOWS:

PHOTOVOLTAIC

"AC" DISCONNECT

"TO BE LOCATED ON EXTERNAL
AC DISCONNECT"

"DC DISCONNECT"
TO BE PERMANENTLY MARKED
AS FOLLOWS:

PHOTOVOLTAIC

"DC" DISCONNECT

"TO BE LOCATED ON EITHER AN
EXTERNAL, OR INVERTER INTEGRATED,
LOCKABLE DC DISCONNECT"

CAUTION:

**SOLAR ELECTRIC
SYSTEM
CONNECTED**

"TO BE APPLIED TO INSIDE OR OUTSIDE OF MAIN
ELECTRICAL PANEL"

**WARNING: PHOTOVOLTAIC
POWER SOURCE**

"TO BE APPLIED TO ALL DC COMBINER
BOXES AND, OR JUNCTION BOXES"

#6

CAUTION: SOLAR CIRCUIT

"TO BE APPLIED TO ALL INTERIOR AND, OR EXTERIOR CONDUIT & RACEWAYS
EVERY 10 FEET, AT TURNS AND, ABOVE & BELOW ALL PENETRATIONS"

#7

RATED AC OPERATING CURRENT:	16.00 AMP
MAX RATED AC OPERATING CURRENT:	20.00 AMP
RATED AC OPERATING VOLTAGE:	240 VAC
MAX RATED AC OPERATING VOLTAGE:	240 VAC
RATED SHORT CIRCUIT CURRENT:	9.04 ISC
MAXIMUM SYSTEM VOLTAGE:	264 VDC

"TO BE PLACED INSIDE DC DISCONNECT" (N.E.C. 690.53)

#8

**PHOTOVOLTAIC
DISCONNECT
WARNING**

ELECTRIC SHOCK HAZARD

DO NOT TOUCH TERMINALS TERMINALS
ON BOTH LINE AND LOAD SIDES MAY BE
ENERGIZED IN THE OPEN POSITION

"TO BE PLACED INSIDE DC DISCONNECT" (N.E.C. 690.17)

#3

**PHOTOVOLTAIC
SOLAR LOAD CENTER**

SUB-PANEL RENDERED UNABLE TO
ACCEPT ADDITIONAL LOADS

"TO BE PLACED ON DEADFRONT INSIDE
DEDICATED SOLAR LOAD CENTER"

#9

**SOLAR BREAKER
DO NOT RELOCATE**

"TO BE PLACED AT DEDICATED CIRCUIT
BREAKER (N.E.C. 690.64(B.4, 7))"

#10

WARNING

DC TERMINALS ON ARRAY SIDE MAY BE ENERGIZED EVEN
WHEN DISCONNECT IS IN OPEN CIRCUIT POSITION CHECK
VOLTAGE AT TERMINALS BEFORE REMOVING CONNECTIONS
UNPLUG MODULES TO COMPLETELY REMOVE UNIT. SEE
MANUAL FOR MORE INFORMATION.

"TO BE PLACED INSIDE DC DISCONNECT" (N.E.C. 690.18)

#11

WARNING

ELECTRIC SHOCK HAZARD
IF GROUND FAULT IS INDICATED NORMALLY GROUNDED
CONDUCTORS MAY BE UNGROUNDED AND ENERGIZED

"TO BE PLACED NEAR GROUND FAULT INDICATOR ON INVERTER"
(N.E.C. 690.5C)

#12

MAX AC OPERATING CURRENT:	20.00 AMPS
AC OPERATING VOLTAGE:	240 VOLTS

"TO BE LOCATED AT POINT OF INTERCONNECTION"

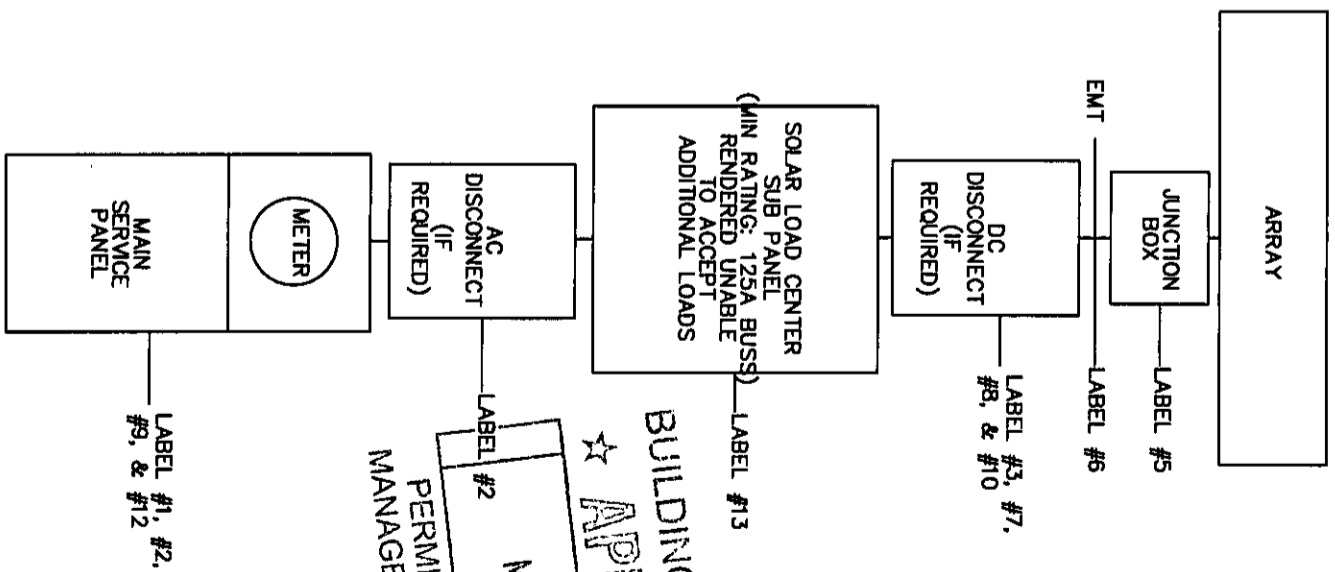

BUILDING PLAN CHECK
APPROVED
MAY 25 2016
PERMIT AND RESOURCE
MANAGEMENT DEPARTMENT

SIGNAGE SCHEDULE



FLORES RESIDENCE
2419 WEST AVE
SANTA ROSA 95407
4.16 KW DC
APN: 043013038

REV	DATE	DESCRIPTION
1	5/23/16	DESCRIPTION 1
2	DY/MT/YEAR	DESCRIPTION 2
3	DY/MT/YEAR	DESCRIPTION 3

DATE: 5/23/2016
SCALE: N.T.S.
SHEET: PV-5

ABBREVIATIONS

A	AMPERE
AC	ALTERNATING CURRENT
AHJ	AUTHORITY-HAVING-JURISDICTION
AZI	AZIMUTH
BLDG	BUILDING
CONC	CONCRETE
CB	COMBINER BOX
CND.	CONDUCTOR
C.S.	CUT SHEET
CU	COPPER
DP	DISTRIBUTION PANEL
DC	DIRECT CURRENT
EGC	EQUIPMENT GROUNDING CND.
(E)	(EXISTING)
FFA	FIRE FIGHTER ACCESS
FV	FIELD VERIFIED
GALV	GALVANIZED
GEC	GROUNDING ELECTRODE CND.
GND	GROUND
HDG	HOT DIPPED GALVANIZED
I	CURRENT
I _{mp}	CURRENT AT MAX POWER
INVT	INVERTER
I _{sc}	SHORT CIRCUIT CURRENT
JBOX	JUNCTION BOX
KVA	KILOVOLT AMPERE
KW	KILOWATT
LBW	LOAD BEARING WALL
MCB	MAIN CIRCUIT BREAKER
MLO	MAIN LUG ONLY
MSP	MAIN SERVICE PANEL
MIN.	MINIMUM
(N)	(NEW)
N3R	NEMA 3R, OUTSIDE RATED
N4R	NEMA 4R, OUTSIDE RATED
NEC	NATIONAL ELECTRICAL CODE
NTS	NOT TO SCALE
OC	ON CENTER
O.C.P.D.	OVER-CURRENT-PROTECTION-DEVICE
P	POLES (BREAKER POLES)
PL	PROPERTY LINES
PV	PHOTOVOLTAIC
PVC	POLYVINYL CHLORIDE
RR	ROOF RAFTER
SBC	SOLID BARE COPPER
SCH	SCHEDULE
SLC	SOLAR LOAD CENTER
SUB	SUBPANEL
(TYPICAL)	INSTALLATION METHOD TO FOLLOW MANUFACTURE SPECIFICATIONS UNLESS NOTED OTHERWISE
U.N.O.	UNLESS NOTED OTHERWISE
V	VOLT
V _{mp}	VLOTAGE AT MAX POWER
V _{oc}	VOLTAGE AT OPEN CIRCUIT
W	WATT

ELECTRICAL NOTES

- 1) INSTALLATION SHALL MEET ALL APPLICABLE SAFETY AND PERFORMANCE STANDARDS ESTABLISHED BY THE NATIONAL ELECTRIC CODE, THE INSTITUTE OF ELECTRICAL AND ELECTRONICS ENGINEERS, AND ACCREDITED TESTING LABORATORY SUCH AS UNDERWRITERS LABORATORIES, AND WHERE APPLICABLE, RULE OF THE PUBLIC UTILITIES COMMISSION REGARDING SAFETY AND RELIABILITY, AS WELL AS MEET ALL UTILITY REQUIREMENTS.
- 2) AC DISCONNECT SWITCH SHALL BE LOCKABLE, VISIBLE AND ACCESSIBLE WITHOUT ANY OBSTRUCTIONS SUCH AS GATES, FENCES OR WALLS.
- 3) ALL MODULES WILL BE GROUNDED IN ACCORDANCE WITH CODE AND THE MANUFACTURER'S INSTALLATION INSTRUCTIONS.
- 4) NOTIFY SERVING UTILITY BEFORE ACTIVATION OF PV SYSTEM.
- 5) WHEN A BACKFEED BREAKER IS THE METHOD OF UTILITY INTERCONNECTION, THE BREAKER SHALL BE INSTALLED AT THE OPPOSITE END OF THE BUS BAR OF THE MAIN BREAKER.
- 6) WORK CLEARANCES AROUND ELECTRICAL EQUIPMENT WILL BE MAINTAINED PER NEC 110.26(A)(1), 110.26(A)(2) & 110.26(A)(3).
- 7) ALL EXTERIOR CONDUIT FITTINGS IN BOXES SHALL BE RAIN-TIGHT AND APPROVED FOR USE IN WET LOCATIONS PER NEC 314.15.
- 8) ALL METALLIC RACEWAYS AND EQUIPMENT SHALL BE BONDED AND ELECTRICALLY CONTINUOUS.
- 9) ALL PV EQUIPMENT, SYSTEMS AND ALL ASSOCIATED WIRING AND INTERCONNECTIONS SHALL BE INSTALLED BY QUALIFIED PERSONS.
- 10) THE PHOTOVOLTAIC SYSTEM CONDUCTOR SHALL BE IDENTIFIED AND GROUP. THE MEANS OF IDENTIFICATION SHALL BE PERMITTED BY SEPARATE COLOR CODING, MARKING TAPE, TAGGING OR OTHER APPROVED MEANS. NEC 690.4(B)
- 11) ADEQUATE SPACING MUST BE MAINTAINED BETWEEN ANY PLUMBING SEWER VENTS EXTENDING THROUGH THE ROOF AND THE UNDERSIDE OF THE PHOTOVOLTAIC PANELS.
- 12) PV EQUIPMENT SYSTEMS AND ALL ASSOCIATED WIRING AND INTERCONNECTIONS SHALL ONLY BE INSTALLED BY QUALIFIED PERSONS PER NEC 690.4(E)
- 13) PHOTOVOLTAIC SYSTEM CONDUCTOR SHALL BE IDENTIFIED AND GROUPED. THE MEANS OF IDENTIFICATION AND SHALL BE PERMITTED SEPARATE COLOR CODING, MARKING TAPE, TAGGING OR OTHER APPROVED MEANS. NEC 690.4(B)
- 14) CONDUIT IS 3.5" - 5" ABOVE ROOF DECK, USED ASHRAE DATA FOR CONDUIT ABOVE 3.5" AND BELOW 12". USED CHART 310.16 OF THE 2013 NEC USING APPROPRIATE AMBIENT TEMPERATURES.

EXTRA DETAILS

BUILDING PLAN CHECK
 ☆ **APPROVED** ☆
 MAY 25 2016
 PERMIT AND RESOURCE
 MANAGEMENT DEPARTMENT

FLORES RESIDENCE
 2419 WEST AVE
 SANTA ROSA 95407
 4.16 KW DC
 APN: 043013038



REV	DATE	DESCRIPTION
1	5/23/16	DESCRIPTION 1
2	DY/MT/YEAR	DESCRIPTION 2
3	DY/MT/YEAR	DESCRIPTION 3

DRAWN BY: ZACHARY LANDES MK
 REVIEWED:

DATE:	5/23/2016
SCALE:	N/A
SHEET:	PV-6

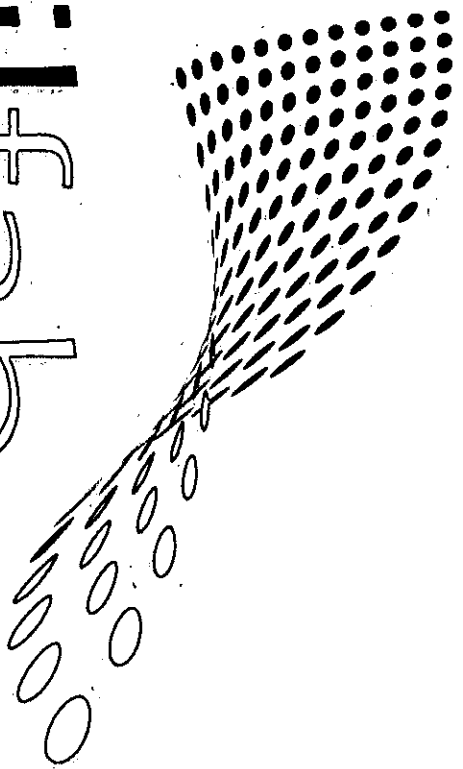

Sifab SOLAR

Sifab Solar Inc.
 PV Module Data Sheet
 SLA-M 260/265/270/275/280/285/290

MONOCRYSTALLINE
 PV MODULE

SLA-M 260/265/270/275/280/285/290

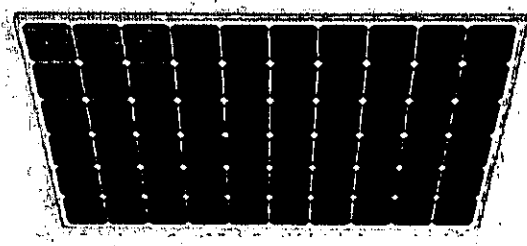

The Sifab SLA-M 60-cell monocrystalline modules are ideal for ground-mount, roof-top and solar tracking installations where maximum power density is required.

Maximum Efficiency... 60 of the highest efficiency, best quality monocrystalline cells result in a maximum power rating of 290 Wp.

Positive Tolerance... (-0/+5W) module sorting achieves the maximum electrical performance of the PV system.

Highest Automation... Strict quality controls during each step of the world's most automated module production facilities.

Increased Quality... Top quality materials and 100% EL testing guarantee a trustworthy 25-year performance warranty.

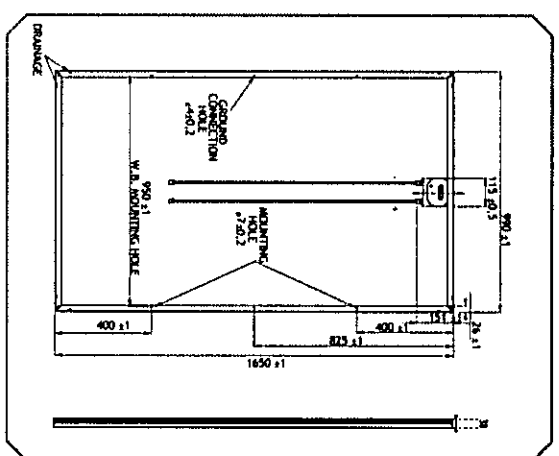

60 CELLS
 12 YEARS

CE IEC (UL) Fraunhofer

Electrical Specifications - Standard Test Conditions		SLA260M	SLA265M	SLA270M	SLA275M	SLA280M	SLA285M	SLA290M
Module Power (Pmax)	Wp	260	265	270	275	280	285	290
Maximum power voltage (Vmp)	V	30.8	31.0	31.2	31.4	31.7	32.0	32.4
Maximum power current (Imp)	A	8.49	8.55	8.65	8.76	8.83	8.91	8.97
Open circuit voltage (Voc)	V	37.8	38.0	38.2	38.4	38.7	39.1	39.6
Short circuit current (Isc)	A	9.04	9.11	9.22	9.32	9.40	9.47	9.54
Module efficiency	%	15.9	16.2	16.5	16.8	17.1	17.4	17.8
Maximum system voltage (VDC)	V	1000						
Series fuse rating	A	15						
Power tolerance	Wp	±0/+5						
Measurement conditions: STC 1000 W/m² • AM 1.5 • Temperature 25 °C • Measurement uncertainty ± 3% • Sun simulator calibration with modules calibrated by Fraunhofer Institute.								
Electrical characteristics may vary by ±5% and power by -0/+5W.								

Temperature Ratings		SLA260M/265M/270M/275M/280M/285M/290M
Temperature Coefficient Isc	%/K	0.03
Temperature Coefficient Voc	%/K	-0.30
Temperature Coefficient Pmax	%/K	-0.38
NOCT (± 2 °C)	°C	45
Operating Temperature	°C	-40/+85

Mechanical Properties and Components		SLA260M/265M/270M/275M/280M/285M/290M
Module weight (± 1 kg)	kg	19
Dimensions (H x L x D; ± 1mm)	mm	1650 x 990 x 38
Maximum surface load (wind/snow)*	N/m²	5400
Hail impact resistance		Ø 25 mm at 83 km/h
Cells		60 - Si monocrystalline - 3 busbar - 156 x 156 mm PERMIT AND RESERVE
Encapsulant		3.2 mm high transmittance, tempered, antireflective coating
Backsheet		PID-resistant EVA MANAGEMENT DESIGN
Frame		Multilayer polyester-based Anodized Al
Bypass diodes		6 diodes - 45V/12A
Cables and connectors		1300 mm Ø 5.7 mm (4 mm²), MC4 compatible
Warranties		SLA260M/265M/270M/275M/280M/285M/290M
Module warranty		12 years
Guaranteed power		± 0.7% end of 1 st year ± 0.6% end of 12 th year ± 0.2% end of 25 th year

Certifications		SLA260M/265M/270M/275M/280M/285M/290M
Product		ULC ORD C1703, UL 1703, IEC 61215, IEC 61730, CEC listed
Factory		Product traceability ISO 9001:2008

Also available as... Sifab Smart Module Optimized by: **Tigo** energy

FLORES RESIDENCE
 2419 WEST AVE
 SANTA ROSA 95407
 4.16 KW DC
 APN: 043013038

Syntrol SOLAR
 2120 MARCH RD. #A, NORVILLE, CA 95747 • PH: (916) 772-8813 - LIC # 72854 - www.syntrol.net

REV	DATE	DESCRIPTION
1	8/23/16	DESCRIPTION 1
2	DY/MT/YEAR	DESCRIPTION 2
3	DY/MT/YEAR	DESCRIPTION 3

DESIGNED BY: ZACHARY LANDIS MK
 DRAWN BY: ZACHARY LANDIS MK
 DATE: 5/23/2016
 SCALE:
 SHEET: PAN

Enphase® Microinverters

Enphase® M215

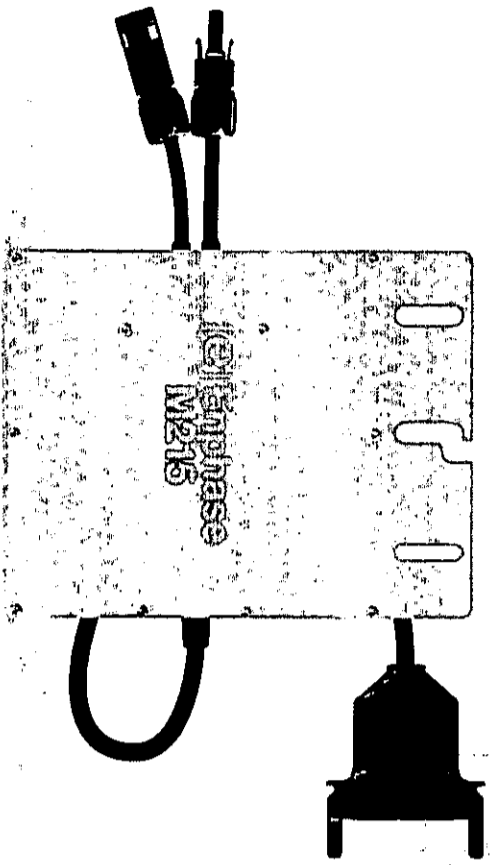

The Enphase® M215 Microinverter with integrated ground delivers increased energy harvest and reduces design and installation complexity with its all-AC approach. With the advanced M215, the DC circuit is isolated and insulated from ground, so **no Ground Electrode Conductor (GEC) is required for the microinverter**. This further simplifies installation, enhances safety, and saves on labor and materials costs.

The Enphase M215 integrates seamlessly with the Engage® Cable, the Envoy® Communications Gateway™, and Enlighten®, Enphase's monitoring and analysis software.

PRODUCTIVE

- Maximizes energy production
- Minimizes impact of shading, dust, and debris
- No single point of system failure

SIMPLE

- No GFC needed for microinverter
- No DC design or string calculation required
- Easy installation with Engage Cable

RELIABLE

- More than 1 million hours of testing and millions of units shipped
- Industry-leading warranty, up to 25 years

[e] enphase®
ENERGY



Enphase® M215 Microinverter // DATA

INPUT DATA (DC)

Recommended input power (STC)	M215-60-2LL-S22-IG, M215-60-2LL-S25-IG	190 - 270 W
Maximum input DC voltage		48 V
Peak power tracking voltage		27 V - 39 V
Operating range		16 V - 48 V
Min/Max start voltage		22 V / 48 V
Max DC short circuit current		15 A

OUTPUT DATA (AC)

	@208 VAC	@240 VAC
Peak output power	225 W	225 W
Rated (continuous) output power	215 W	215 W
Nominal output current	1.03 A (A rms at nominal duration)	0.9 A (A rms at nominal duration)
Nominal voltage/range	208 V / 183-229 V	240 V / 211-264 V
Nominal frequency/range	60.0 / 57-61 Hz	60.0 / 57-61 Hz
Extended frequency range*	57-62.5 Hz	57-62.5 Hz
Power factor	>0.95	>0.95
Maximum units per 20 A branch circuit	25 (three phase)	17 (single phase)
Maximum output fault current	850 mA rms for 6 cycles	850 mA rms for 6 cycles

EFFICIENCY

CEC weighted efficiency, 240 VAC	96.5%
CEC weighted efficiency, 208 VAC	96.5%
Peak inverter efficiency	96.5%
Static MPPT efficiency (weighted, reference ENS0530)	99.4 %
Night time power consumption	65 mW max

MECHANICAL DATA

Ambient temperature range	-40°C to +65°C
Dimensions (WxHxD)	171 mm x 173 mm x 30 mm (without mounting brackets)
Weight	1.6 kg (3.4 lbs)
Cooling	Natural convection - No fans
Enclosure environmental rating	Outdoor - NEMA 6
Connector type	M215-60-2LL-S22-IG: MC4 M215-60-2LL-S25-IG: Amphenol H4

FEATURES

- Compatibility**
Compatible with 60-cell PV modules.
 - Communication**
Power line
 - Integrated ground**
The DC circuit meets the requirements for ungrounded PV arrays in NEC 690.35. Equipment ground is provided in the Engage Cable. No additional GEC or ground is required. Ground fault protection (GFP) is integrated into the microinverter.
 - Monitoring**
Enlighten Manager and MyEnlighten monitoring options
 - Compliance**
UL1741/IEEE1547, FCC Part 15 Class B, CAN/CSA-C22.2 NO. 0-M91, 0-4-04, and 107.1-01
- * Frequency ranges can be extended beyond nominal if required by the utility

To learn more about Enphase Microinverter technology, visit enphase.com

© 2015 Enphase Energy. All rights reserved. All trademarks or brands in this document are registered by their respective owner.

[e] enphase®
ENERGY

MKT-00099 Rev. 1.0

FLORES RESIDENCE
2419 WEST AVE
SANTA ROSA 95407
4.16 KW DC
APN: 043013038

Syntrol SOLAR

2120 MARCH RD. #A, ROSELVILLE, CA 95747 • PH: (916) 772-8613 • LIC # 728304 • www.syntrol.net

BUILDING PLAN CHECK
APPROVED
MAY 25 2016
PERMIT AND RESOURCE
MANAGEMENT DEPARTMENT

REV	DATE	DESCRIPTION
1	5/23/16	DESCRIPTION 1
2	DYMT/YEAR	DESCRIPTION 2
3	DYMT/YEAR	DESCRIPTION 3

DRAWN BY: ZACHARY LANDIS MK
REVIEW:



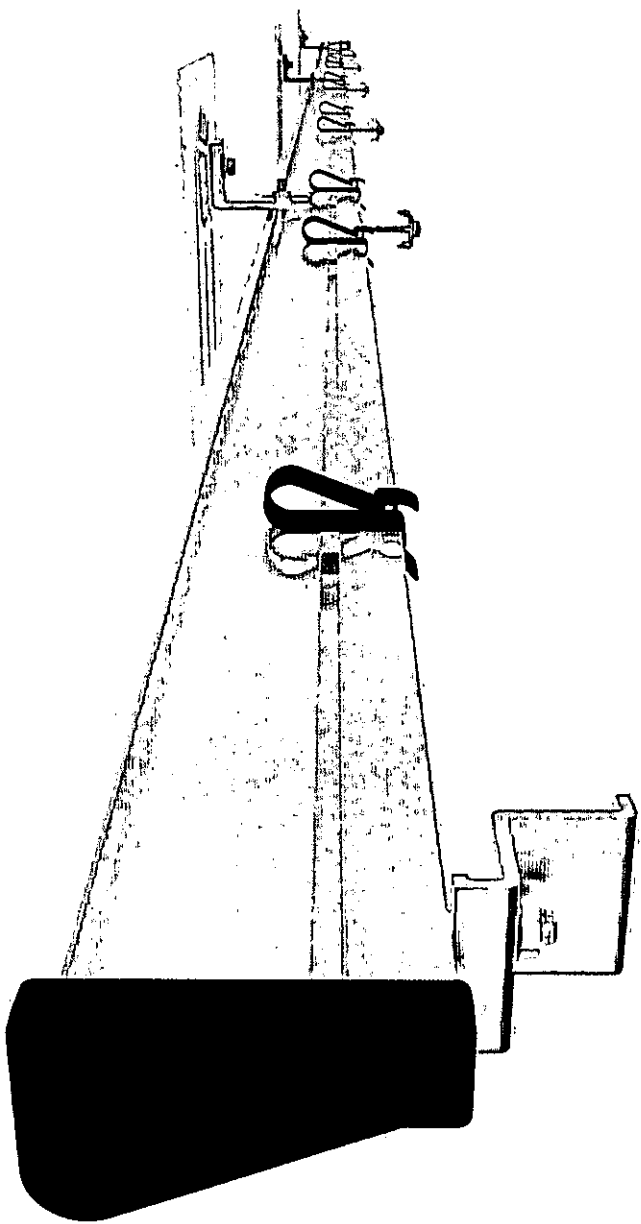



DATE: 5/23/2016
SCALE:
SHEET: INV



Built for solar's toughest roofs.

Anchored by the strongest rails in solar, the IronRidge Roof Mount System provides the durability and versatility to handle virtually any residential or commercial rooftop.

The unique curved profile of the XRS Rail increases its strength while also giving it an attractive look, making it very customer-friendly. In addition, IronRidge Rails are certified for integrated grounding, which eliminates separate module grounding components and procedures, making it very installer-friendly.

- | | | |
|---|-----------------------------|---|
|  | Strongest Rails | Longer spans between attachments, fewer roof penetrations. |
|  | Simple Assembly | Versatile and adjustable components simplify any array design. |
|  | Integrated Grounding | UL 2703 system eliminates separate module grounding components. |
|  | PE Certified | Pre-stamped engineering letters available in most states. |
|  | Design Software | Online tool generates a complete bill of materials in minutes. |
|  | 20 Year Warranty | Twice the protection offered by competitors. |

Rails

Standard Rails (XRS)

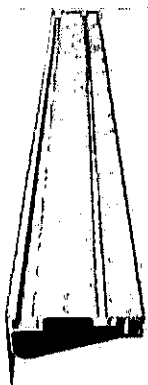

- Curved rails increase spanning capabilities and aesthetics.
- Available in clear and black anod.
- Multiple sizes between 12' and 18'
- Made of corrosion resistant alum.

Light Rails (XRL)



- Lightweight rails reduce cost for lighter load conditions.
- Available in clear and black anod.
- Multiple sizes between 12' and 18'
- Made of corrosion resistant alum.

Rail Splices

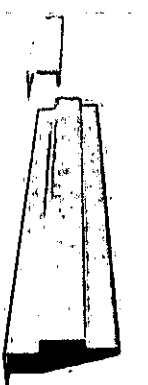

- Internal splices seamlessly connect rails, allowing easy L-foot installation.
- Different versions for XRS and XRL
- Includes self-tapping screws
- Available with grounding straps

Attachments

Flashings

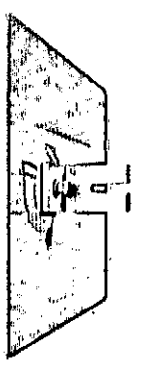

- FlashFoot™ is an all-in-one mounting product for composition shingle roofs.
- Integrated L-Foot and hardware
- Certified compliant with IBC & IFBC
- PE certified with IronRidge Rails

Adjustable L-Feet

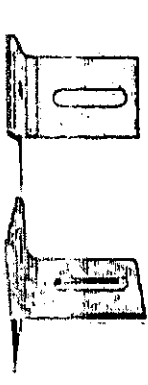

- Slotted L-feet provide adaptable attachment to standoffs and flashings.
- Available in clear and black anod.
- Works with XRS and XRL rails
- Compatible with third-party parts

Tilt Leg Kits



- Fixed and adjustable tilt legs allow adjustment in all three axes.
- Attaches directly to XRS and XRL rails
- Ships with all required hardware
- Multiple sizes for 5-45 deg tilts

Clamps & Accessories

End Clamps

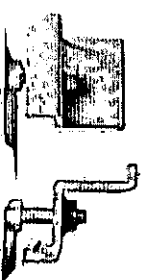

- Secure modules to the end of the rails.
- Clear and black anod.
- Sizes from 1.22" to 2.3"
- Optional bottom clamps

Mid Clamps



- Fasten modules in the middle of the rails.
- Clear and black anod.
- T-bolt or hex nut designs
- Grounding clamp offered

End Caps



- Provide a finished look for rails.
- Keeps out debris
- Black polycarbonate
- UV protected

Online Software



The IronRidge Design Assistant helps you go from rough layout to fully engineered system. For free. Go to ironridge.com/m

Available with Integrated Grounding

IronRidge offers UL 2703 certified components that automatically bond modules and rails to ground. Go to ironridge.com/ig

FLORES RESIDENCE
2419 WEST AVE
SANTA ROSA 95407
4.16 KW DC
APN: 043013038

PERMIT AND RESOURCE MANAGEMENT DEPARTMENT
MAY 25 2016
WIRE CLIPS

CUTSHEET

REV	DATE	DESCRIPTION
1	5/23/16	DESCRIPTION 1
2	DY/MY/YEAR	DESCRIPTION 2
3	DY/MY/YEAR	DESCRIPTION 3



FlashFoot™

Teach Brief

Rapid & Secure Solar Attachments

IronRidge FlashFoot™ is an all-in-one solar mounting product for composition shingle roofs that eliminates the need for separate standoffs, flashings, and L-feet.

FlashFoot incorporates a number of structural and waterproofing features to securely attach IronRidge Rails to roof structures, while also protecting against water intrusion and weather damage.

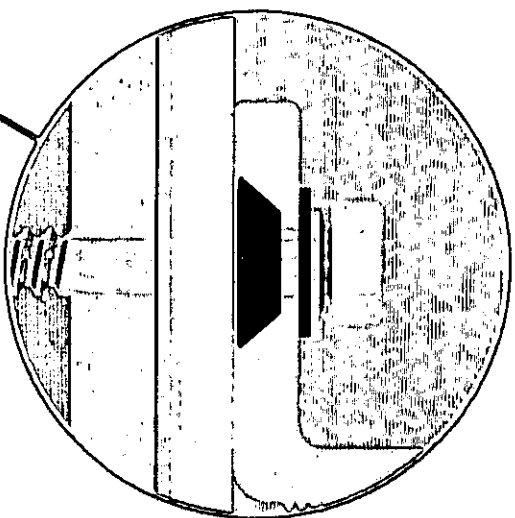

Dual Mechanical Seal

At the core of the FlashFoot, a pre-installed rubber bushing forms a dual mechanical seal, with its exterior compressed against the cavity of the L-foot and its interior tightly wrapping around the shaft of the lag bolt.

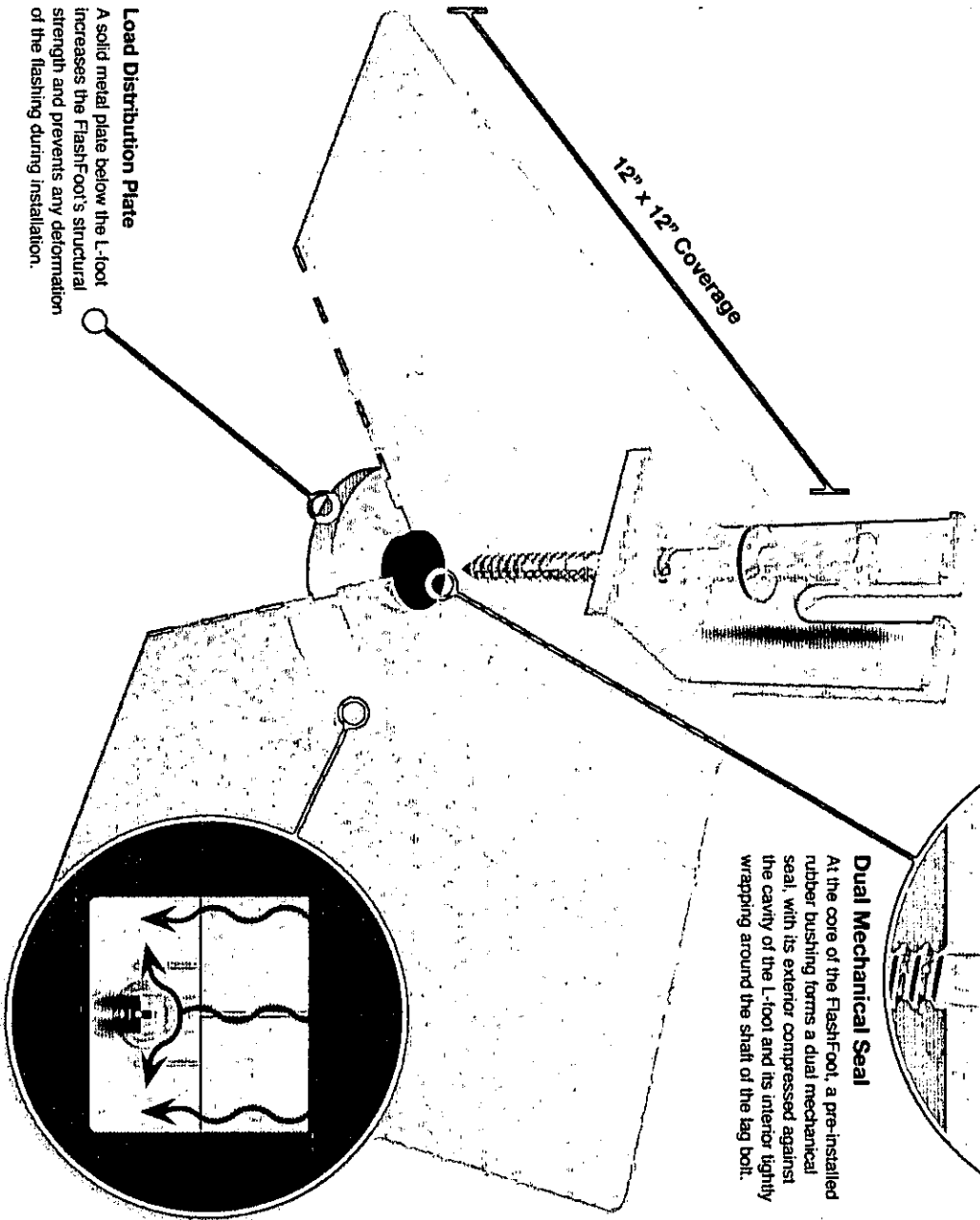

Load Distribution Plate

A solid metal plate below the L-foot increases the FlashFoot's structural strength and prevents any deformation of the flashing during installation.

Water Shedding Design

A wide flashing layer combined with an elevated sealing platform maximizes the FlashFoot's water shedding ability.

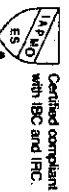

Certified compliant with IBC and ICC.

Installation Overview

Teach Brief

Tools Required: tape measure, chalk line, stud finder, roofing bar, caulking gun with an approved sealant, drill with 1/4" bit and 1/2" socket.

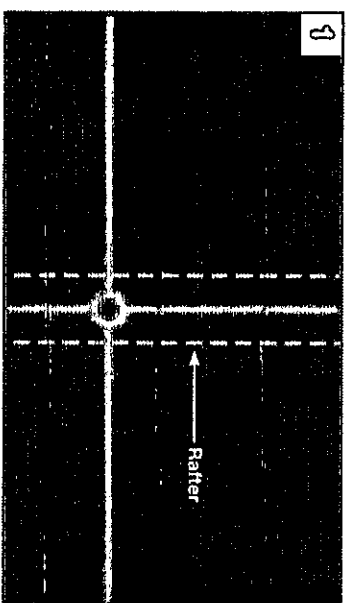

Locate rafters and snap vertical and horizontal lines to mark locations of flashings. Drill 1/4" pilot holes, then backfill with an approved sealant.

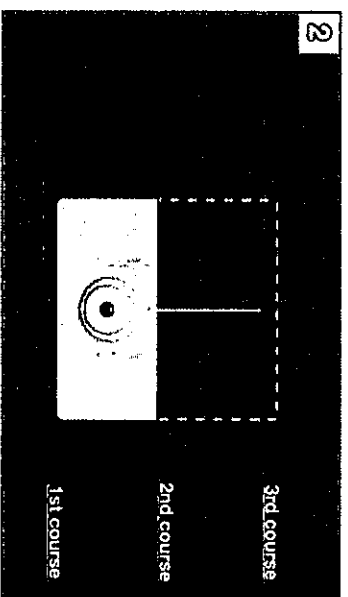

Slide flashing, between 1st and 2nd course, so the top is at least 3/4" above the edge of the 3rd course and the bottom is above the edge of the 1st course.

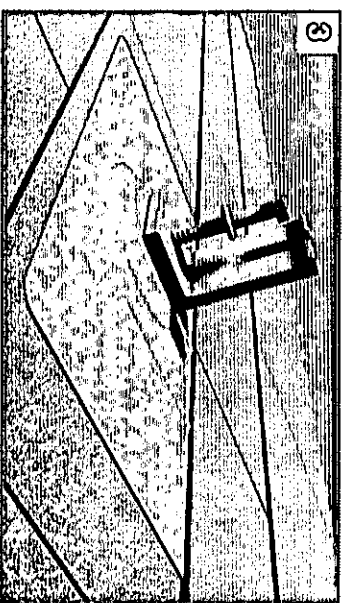

Line up pilot hole with flashing hole and insert lag bolt through bonded washer, L-Foot, and flashing. Tighten lag bolt until fully seated.

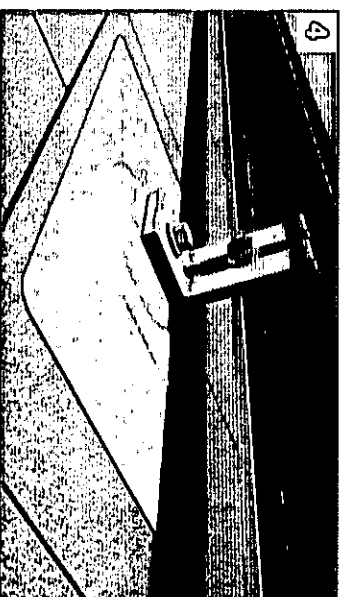

The FlashFoot is now installed and ready for use. IronRidge Rails. With provided L-foot fasteners pre-loaded into rails, drop rails into open L-foot slots.

Testing & Certification

FlashFoot is certified for compliance with the International Building Codes (IBC) & International Residential Codes (IRC) by IAPMO-ES. Mechanical testing conformed to the standard for Testing and Analysis of Joints Hangers and Miscellaneous Connectors (ECC002-2011), and rain testing conformed to the Underwriters Laboratory Standard for Gas Vents (UL 441-96 Section 25).

Log Product (Manufacturer/Specification/Field Approval Number (FAN))	Specific Gravity	30 Day Strength (psi)
Douglas Fir, Larch	50	798
Douglas Fir, South	46	705
Engelmann Spruce, Lodgepole Pine (MSR 1650 I & Higher)	46	705
Hem, Fir	43	636
Hem, Fir (North)	46	705
Southern Pine	55	821
Species, Pine, Fir	42	615
Species, Pine, Fir (1 of 2 million psi and higher grades of MSR and MCL)	50	798

Source: American Wood Council, WCC 2002, Table 11.24, 11.24a, 11.24b. 3' Thermal break for installation of a rafter or other structural member. 3.5psi GCR for required edge distance.

MAY 25 2016
RESIDENTIAL DEPARTMENT
CUTSHEET



FLORES RESIDENCE
2419 WEST AVE
SANTA ROSA 95407
4.16 KW DC
APN: 043013038

REV	DATE	DESCRIPTION
1	5/23/16	DESCRIPTION 1
2	DYMT/YEAR	DESCRIPTION 2
3	DYMT/YEAR	DESCRIPTION 3

DATE: 5/23/2016
SCALE:
SHEET: MNT

☆ APPROVED ☆
—AS NOTED—

APPROVED BY
[Signature]

PERMIT NO.
BDV 2665

PERMIT AND RESOURCE MANAGEMENT
DEPARTMENT

APPROVED JOB OFFICE PLANS AND JOB CARDS TO BE

ON JOB SITE.
ALL CHANGES MADE IN THE APPROVED
BUILDER'S PLANS SHALL BE MADE IN WRITING AND
PLANS, PERMITS, AND RESOURCE MANAGEMENT DEPARTMENT. CHANGES MADE
WRITING DEPARTMENT SHALL BE SUBJECT TO
MANAGEMENT DEPARTMENT REVIEW AND APPROVAL.
WITHOUT THE APPROVED PERMIT TO, AND DOES
REJECT.
APPROVALS OF PERMITS, SPECIAL INSPECTIONS, SPECIAL
NOT AUTHORIZED PERMITS, SPECIAL INSPECTIONS, SPECIAL
COMPLIANCE WITH PERMITS, SPECIAL INSPECTIONS, SPECIAL
INSPECTIONS, SPECIAL INSPECTIONS, SPECIAL INSPECTIONS
PLEASE READ ALL PERTINENT SECTIONS OF
APPLICABLE CODES.

Frequently Asked Questions

What is a "module type"?

The new UL1703 standard introduces the concept of a PV module type, based on 4 construction parameters and 2 fire performance parameters. The purpose of this classification is to certify mounting systems without needing to test it with every module.

What roofing materials are covered?

All fire rated roofing materials are covered within this certification including composition shingle, clay and cement tile, metal, and membrane roofs.

What if I have a Class C roof, but the jurisdiction now requires Class A or B?

Generally, older roofs will typically be "grandfathered in", and will not require re-roofing. However, if 50% or more of the roofing material is replaced for the solar installation the code requirement will be enforced.

Where is the new fire rating requirement code listed?

2012 IBC: 1509.7.2 Fire classification. Rooftop mounted photovoltaic systems shall have the same fire classification as the roof assembly required by Section 1505.

Where is a Class A Fire Rating required?

The general requirement for roofing systems in the IBC refers to a Class C fire rating. Class A or B is required for areas such as Wildland Urban Interface areas (WUI) and for very high fire severity areas. Many of these areas are found throughout the western United States. California has the most Class A and B roof fire rating requirements, due to wild fire concerns.

Are standard mid clamps covered?

Mid clamps and end clamps are considered part of the PV "system", and are covered in the certification.

What attachments and flashings are deemed compatible with Class A?

Attachments and their respective flashings are not constituents of the rating at this time. All code-compliant flashing methods are acceptable from a fire rating standpoint.

What mounting height is acceptable?

UL fire testing was performed with a gap of 5", which is considered worst case in the standard. Therefore, the rating is applicable to any module to roof gap.

Am I required to install skirting to meet the fire code?

No, IronRidge achieved a Class A fire rating without any additional racking components.

What determines Fire Classification?

Fire Classification refers to a fire-resistance rating system for roof covering materials based on their ability to withstand fire exposure.

- Class A - effective against severe fire exposure*
- Class B - effective against moderate fire exposure*
- Class C - effective against light fire exposure*

What if the roof covering is not Class A rated?

The IronRidge Class A rating will not diminish the fire rating of the roof, whether Class A, B, or C.

What tilts is the tilt mount system fire rated for?

The tilt mount system is rated for 1 degrees and up and any roof to module gap, or mounting height.

More Resources

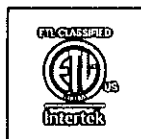

Fire Rating Certificate

Visit our website to download the official UL 2703 certification document.

Go to IronRidge.com

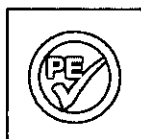

Engineering Certification Letters

We offer complete engineering resources and pre-stamped certification letters.

Go to IronRidge.com



Class A Fire Rating

Background

All roofing products are tested and classified for their ability to resist fire.

Recently, these fire resistance standards were expanded to include solar equipment as part of the roof system. Specifically, this requires the modules, mounting hardware and roof covering to be tested together as a system to ensure they achieve the same fire rating as the original roof covering.

Adoption of these new requirements will begin in California in 2015 and extend to the rest of the country in 2016.

IronRidge Certification

In August 2014, IronRidge was the first company to receive a Class A Fire Rating—the highest possible rating—from Intertek Group plc., a Nationally Recognized Testing Laboratory.

IronRidge Roof Mount products were tested on flat and sloped roofs in accordance with the new UL 1703 & UL 2703 test standards. The testing evaluated the system's ability to resist flame spread, burning material and structural damage to the roof.

Refer to the table below to determine the requirements for achieving a Class A Fire Rating on your next project.

Fire Testing Process

Test Setup

Solar Modules
Solar modules are given a Type classification based on their materials and construction.

Mounting System
Mounting is tested as part of a system that includes type-tested modules and fire-rated roof covering.

Roof Covering
Roof covering products are given a Fire Class Rating of A, B or C based on their tested fire resistance.

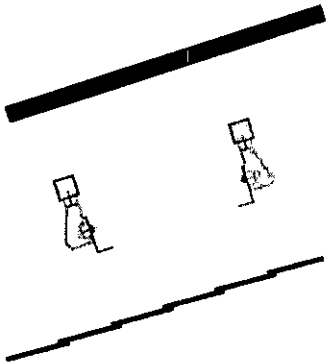

Burning Brand Test

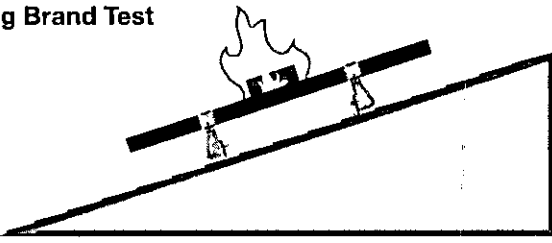



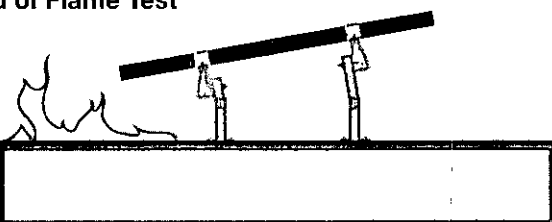

A burning wooden block is placed on module as a fan blows at 12 mph. Flame cannot be seen on underside of roof within 90 minutes.

Spread of Flame Test



Flame at southern edge of roof is aimed up the roof as a fan blows at 12 mph. The flame cannot spread 6 feet or more in 10 minutes.

Roof Slope	Mount	Module	Fire Rating*
Steep Slope (≥ 9.5 degrees)	Flush 	Type 1, 2, & 3	Class A
	Tilt 	Type 1 & 2	Class A
Low Slope (< 9.5 degrees)	Flush 	Type 1, 2, & 3	Class A
	Tilt 	Type 1, 2, & 3	Class A

*Class A rated PV systems can be installed on Class A, B, and C roofs.



AUTHORIZATION TO MARK

This authorizes the application of the Certification Mark(s) shown below to the models described in the Product(s) Covered section when made in accordance with the conditions set forth in the Certification Agreement and Listing Report. This authorization also applies to multiple listee model(s) identified on the correlation page of the Listing Report.

This document is the property of Intertek Testing Services and is not transferable. The certification mark(s) may be applied only at the location of the Party Authorized To Apply Mark.

Applicant: IronRidge, Inc.
Address: 1495 Zephyr Ave
Hayward, CA 94544
Country: USA
Contact: Yann Schwarz
Phone: (800) 227-9523
FAX: (707) 459-1833
Email: yschwarz@ironridge.com

Manufacturer: Precision Die & Stamping, Inc.
Address: 1704 W. 10th Street
Tempe, AZ 85281
Country: USA
Contact: Andy Frola
Phone: (480) 967-2038
FAX: (480) 829-0838
Email: andy@precisiondie.com

Party Authorized To Apply Mark: Same as Manufacturer
Report Issuing Office: Lake Forest, CA

Catherine Dwyer

Control Number: 4008083

Authorized by: _____

for Thomas J. Patterson, Certification Manager



This document supersedes all previous Authorizations to Mark for the noted Report Number.

This Authorization to Mark is for the exclusive use of Intertek's Client and is provided pursuant to the Certification agreement between Intertek and its Client. Intertek's responsibility and liability are limited to the terms and conditions of the agreement. Intertek assumes no liability to any party, other than to the Client in accordance with the agreement, for any loss, expense or damage occasioned by the use of this Authorization to Mark. Only the Client is authorized to permit copying or distribution of this Authorization to Mark and then only in its entirety. Use of Intertek's Certification mark is restricted to the conditions laid out in the agreement and in this Authorization to Mark. Any further use of the Intertek name for the sale or advertisement of the tested material, product or service must first be approved in writing by Intertek. Initial Factory Assessments and Follow up Services are for the purpose of assuring appropriate usage of the Certification mark in accordance with the agreement, they are not for the purposes of production quality control and do not relieve the Client of their obligations in this respect.

Intertek Testing Services NA Inc.
545 East Algonquin Road, Arlington Heights, IL 60005
Telephone 800-345-3851 or 847-439-5667 Fax 312-283-1672

Standard(s):	UL Subject 2703 Outline of Investigation for Rack Mounting Systems and Clamping Devices for Flat-Plate Photovoltaic Modules and Panels, Issue Number: 1, October 4, 2010
Product:	XR Rails with Integrated Grounding.
Brand Name:	IronRidge Roof Mount
Models:	XR Rails

This authorizes the application of the Certification Mark(s) shown below to the models described in the Product(s) Covered section when made in accordance with the conditions set forth in the Certification Agreement and Listing Report. This authorization also applies to multiple listee model(s) identified on the correlation page of the Listing Report.

This document is the property of Intertek Testing Services and is not transferable. The certification mark(s) may be applied only at the location of the Party Authorized To Apply Mark.

Applicant: IronRidge, Inc.
Address: 1495 Zephyr Ave
 Hayward, CA 94544
Country: USA
Contact: Yann Schwarz
Phone: (800) 227-9523
FAX: (707) 459-1833
Email: yschwarz@ironridge.com

Manufacturer: IronRidge, Inc.
Address: 1495 Zephyr Ave
 Hayward, CA 94544
Country: USA
Contact: Jim Norsworthy Or Dave Taggart
Phone: (707) 363-3025
FAX: (510) 225-0975
Email: jnorsworthy@ironridge.com

Party Authorized To Apply Mark: Same as Manufacturer
Report Issuing Office: Lake Forest, CA

Catherine Dwyer

Control Number: 4008377

Authorized by: _____
 for Thomas J. Patterson, Certification Manager

ETL CLASSIFIED



Intertek

This document supersedes all previous Authorizations to Mark for the noted Report Number.

This Authorization to Mark is for the exclusive use of Intertek's Client and is provided pursuant to the Certification agreement between Intertek and its Client. Intertek's responsibility and liability are limited to the terms and conditions of the agreement. Intertek assumes no liability to any party, other than to the Client in accordance with the agreement, for any loss, expense or damage occasioned by the use of this Authorization to Mark. Only the Client is authorized to permit copying or distribution of this Authorization to Mark and then only in its entirety. Use of Intertek's Certification mark is restricted to the conditions laid out in the agreement and in this Authorization to Mark. Any further use of the Intertek name for the sale or advertisement of the tested material, product or service must first be approved in writing by Intertek. Initial Factory Assessments and Follow up Services are for the purpose of assuring appropriate usage of the Certification mark in accordance with the agreement, they are not for the purposes of production quality control and do not relieve the Client of their obligations in this respect.

Intertek Testing Services NA Inc.
 545 East Algonquin Road, Arlington Heights, IL 60005
 Telephone 800-345-3851 or 847-439-5667 Fax 312-283-1672

Standard(s):	UL Subject 2703 Outline of Investigation for Rack Mounting Systems and Clamping Devices for Flat-Plate Photovoltaic Modules and Panels, Issue Number: 1, October 4, 2010
Product:	XR Rails with Integrated Grounding.
Brand Name:	IronRidge Roof Mount
Models:	XR Rails



AUTHORIZATION TO MARK

This authorizes the application of the Certification Mark(s) shown below to the models described in the Product(s) Covered section when made in accordance with the conditions set forth in the Certification Agreement and Listing Report. This authorization also applies to multiple listee model(s) identified on the correlation page of the Listing Report.

This document is the property of Intertek Testing Services and is not transferable. The certification mark(s) may be applied only at the location of the Party Authorized To Apply Mark.

Applicant: IronRidge, Inc.
Address: 1495 Zephyr Ave
Hayward, CA 94544
Country: USA
Contact: Yann Schwarz
Phone: (800) 227-9523
FAX: (707) 459-1833
Email: yschwarz@ironridge.com

Manufacturer: IronRidge, Inc.
Address: 1435 Baechtel Road
Willits, CA 95490
Country: USA
Contact: Jim Norsworthy
Phone: (800) 227-9523
FAX: (707) 459-1833
Email: jnorsworthy@ironridge.com

Party Authorized To Apply Mark: Same as Manufacturer
Report Issuing Office: Lake Forest, CA

Catherine Dwyer

Control Number: 4007559

Authorized by: _____
for Thomas J. Patterson, Certification Manager



This document supersedes all previous Authorizations to Mark for the noted Report Number.

This Authorization to Mark is for the exclusive use of Intertek's Client and is provided pursuant to the Certification agreement between Intertek and its Client. Intertek's responsibility and liability are limited to the terms and conditions of the agreement. Intertek assumes no liability to any party, other than to the Client in accordance with the agreement, for any loss, expense or damage occasioned by the use of this Authorization to Mark. Only the Client is authorized to permit copying or distribution of this Authorization to Mark and then only in its entirety. Use of Intertek's Certification mark is restricted to the conditions laid out in the agreement and in this Authorization to Mark. Any further use of the Intertek name for the sale or advertisement of the tested material, product or service must first be approved in writing by Intertek. Initial Factory Assessments and Follow up Services are for the purpose of assuring appropriate usage of the Certification mark in accordance with the agreement, they are not for the purposes of production quality control and do not relieve the Client of their obligations in this respect.

Intertek Testing Services NA Inc.
545 East Algonquin Road, Arlington Heights, IL 60005
Telephone 800-345-3851 or 847-439-5667 Fax 312-283-1672

Standard(s):	UL Subject 2703 Outline of Investigation for Rack Mounting Systems and Clamping Devices for Flat-Plate Photovoltaic Modules and Panels, Issue Number: 1, October 4, 2010
Product:	XR Rails with Integrated Grounding.
Brand Name:	IronRidge Roof Mount
Models:	XR Rails

THIS EDGE TOWARDS ROOF RIDGE

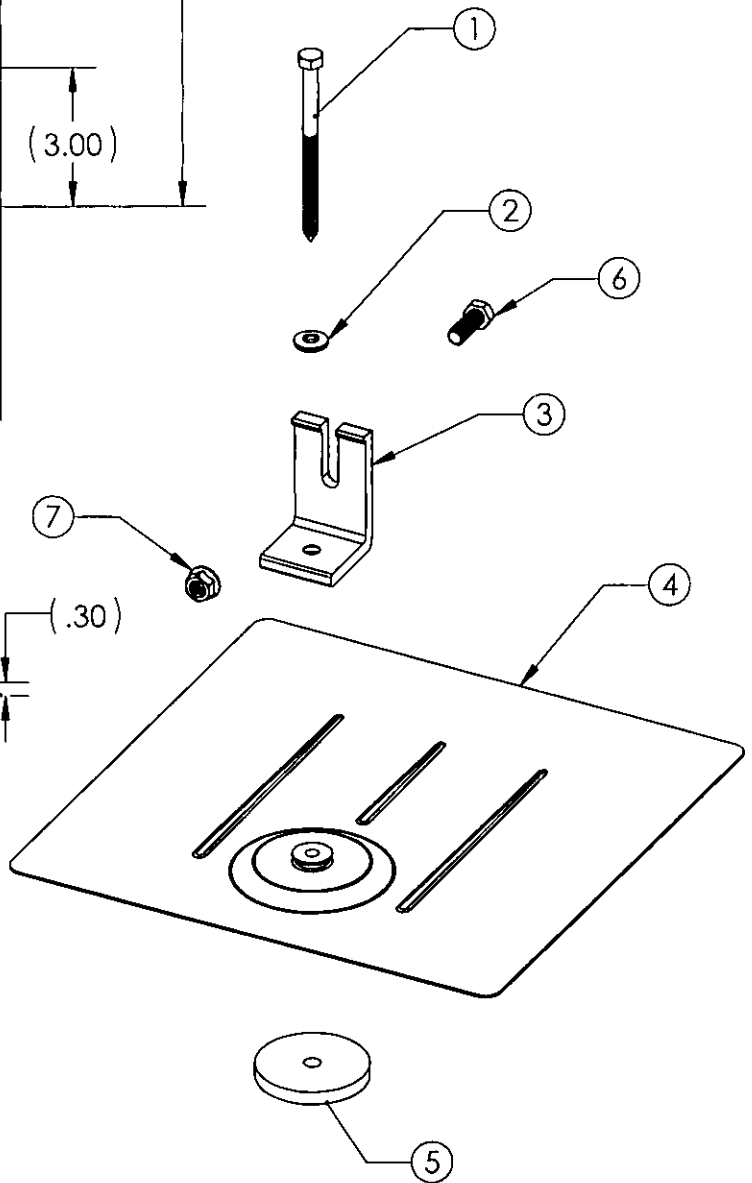
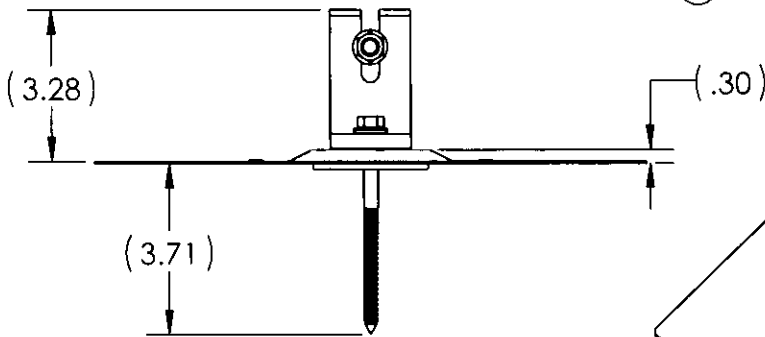
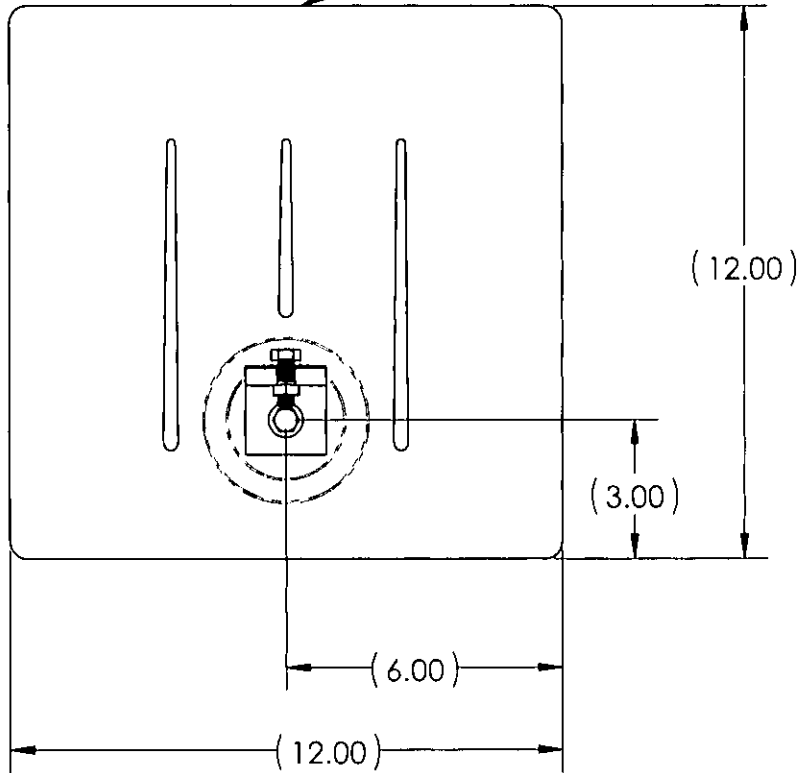

ITEM NO.	DESCRIPTION	QTY
1	LAG BOLT 5/16" - 4 1/2" 18.8 SS	1
2	5/16" EPDM BONDED WASHER 18.8 SS	1
3	SCL-101-3	1
4	IR-GF-FLASHING	1
5	IR-GF-SUPPORT	1
6	BOLT, 3/8-16 X 1" HEX CS SS	1
7	NUT, FLANGE HEX 3/8-16 SS	1

DRAWN	SO	11-19-2013
REVIEWED	SM	11-26-2013
DESIGN APPR	JA	11-16-2013
FIELD APPR	-	-
QA	-	-



KIT, IRONRIDGE FLASH FOOT (L-FOOT INCLUDED)

SIZE	PART NO.	REV
A	RF-FLSH-001	---
SCALE: 1" = 1'	WEIGHT	DATE

IronRidge
Mr. David F. Taggart
IronRidge Flashing

December 18, 2014
Page 11 of 11

Notes – Tabulated values are based on the following criteria:

1. Building mean roof height = 30 ft
2. Risk Category = I
3. Roof Slope = 7 to 27 degrees
4. Solar panel long dimension = 78.5 in
5. Minimum specific gravity of wood rafter = 0.50
6. ASCE 7-10

Our analysis assumes that the connections and associated hardware are installed in a workmanlike manner in accordance with the “IronRidge Roof Mount Installation Manual” by IronRidge and generally accepted standards of construction practice. It is the responsibility of the contractor to verify that the quality of the roof framing meets the minimum properties used in the tests. Additional information is available at the IronRidge web site, IronRidge.com.

Please feel free to contact me at your convenience if you have any questions.

Respectfully yours,

Tres J. Warner, P.E.
Design Division Manager

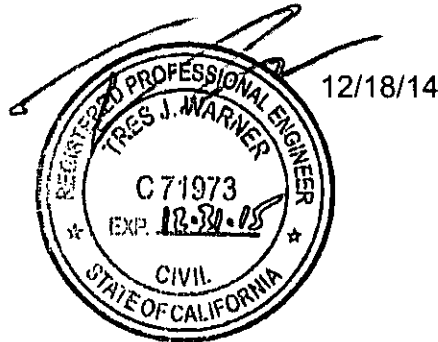

Table 9 - MAXIMUM SPANS (inches) - Wind Zone 3											
XR1000 Rail FlashFoot	Wind Speed	Ground Snow Load									
Exposure	mph	0 psf	10 psf	20 psf	30 psf	40 psf	50 psf	60 psf	70 psf	80 psf	90 psf
Category B	100	107	107	101	88	77	70	64	60	56	53
	105	102	102	101	88	77	70	64	60	56	53
	110	98	98	98	88	77	70	64	60	56	53
	120	83	83	83	83	77	70	64	60	56	53
	130	71	71	71	71	71	70	64	60	56	53
	140	61	61	61	61	61	61	61	60	56	53
	150	53	53	53	53	53	53	53	53	53	53
	160	47	47	47	47	47	47	47	47	47	47
	170	41	41	41	41	41	41	41	41	41	41
Category C	100	85	85	85	85	77	70	64	60	56	53
	105	77	77	77	77	77	70	64	60	56	53
	110	70	70	70	70	70	70	64	60	56	53
	120	59	59	59	59	59	59	59	59	56	53
	130	50	50	50	50	50	50	50	50	50	50
	140	43	43	43	43	43	43	43	43	43	43
	150	38	38	38	38	38	38	38	38	38	38
	160	33	33	33	33	33	33	33	33	33	33
	170	29	29	29	29	29	29	29	29	29	29
Category D	100	72	72	72	72	72	70	64	60	56	53
	105	65	65	65	65	65	65	64	60	56	53
	110	59	59	59	59	59	59	59	59	56	53
	120	50	50	50	50	50	50	50	50	50	50
	130	42	42	42	42	42	42	42	42	42	42
	140	37	37	37	37	37	37	37	37	37	37
	150	32	32	32	32	32	32	32	32	32	32
	160	28	28	28	28	28	28	28	28	28	28
	170	25	25	25	25	25	25	25	25	25	25

Notes -- see page 11

Table 8 - MAXIMUM SPANS (inches) - Wind Zone 2											
XR1000 Rail FlashFoot	Wind Speed	Ground Snow Load									
Exposure	mph	0 psf	10 psf	20 psf	30 psf	40 psf	50 psf	60 psf	70 psf	80 psf	90 psf
Category B	100	131	119	101	88	77	70	64	60	56	53
	105	125	119	101	88	77	70	64	60	56	53
	110	120	119	101	88	77	70	64	60	56	53
	120	110	110	101	88	77	70	64	60	56	53
	130	102	102	101	88	77	70	64	60	56	53
	140	93	93	93	88	77	70	64	60	56	53
	150	81	81	81	81	77	70	64	60	56	53
	160	71	71	71	71	71	70	64	60	56	53
Category C	100	112	112	101	88	77	70	64	60	56	53
	105	107	107	101	88	77	70	64	60	56	53
	110	102	102	101	88	77	70	64	60	56	53
	120	91	91	91	88	77	70	64	60	56	53
	130	77	77	77	77	77	70	64	60	56	53
	140	67	67	67	67	67	67	64	60	56	53
	150	58	58	58	58	58	58	58	58	56	53
	160	51	51	51	51	51	51	51	51	51	51
Category D	100	103	103	101	88	77	70	64	60	56	53
	105	98	98	98	88	77	70	64	60	56	53
	110	91	91	91	88	77	70	64	60	56	53
	120	77	77	77	77	77	70	64	60	56	53
	130	65	65	65	65	65	65	64	60	56	53
	140	56	56	56	56	56	56	56	56	56	53
	150	49	49	49	49	49	49	49	49	49	49
	160	43	43	43	43	43	43	43	43	43	43
170	38	38	38	38	38	38	38	38	38	38	

Notes – see page 11

Table 7 - MAXIMUM SPANS (inches) - Wind Zone 1											
XR1000 Rail FlashFoot	Wind Speed	Ground Snow Load									
Exposure	mph	0 psf	10 psf	20 psf	30 psf	40 psf	50 psf	60 psf	70 psf	80 psf	90 psf
Category B	100	138	119	101	88	77	70	64	60	56	53
	105	138	119	101	88	77	70	64	60	56	53
	110	138	119	101	88	77	70	64	60	56	53
	120	138	119	101	88	77	70	64	60	56	53
	130	138	119	101	88	77	70	64	60	56	53
	140	128	119	101	88	77	70	64	60	56	53
	150	120	117	100	88	77	70	64	60	56	53
	160	113	113	98	87	77	70	64	60	56	53
	170	107	107	97	86	77	70	64	60	56	53
Category C	100	138	119	101	88	77	70	64	60	56	53
	105	138	119	101	88	77	70	64	60	56	53
	110	137	119	101	88	77	70	64	60	56	53
	120	127	119	101	88	77	70	64	60	56	53
	130	118	116	99	88	77	70	64	60	56	53
	140	110	110	97	87	77	70	64	60	56	53
	150	103	103	95	85	77	70	64	60	56	53
	160	96	96	93	84	76	70	64	60	56	53
	170	85	85	85	82	75	70	64	60	56	53
Category D	100	138	119	101	88	77	70	64	60	56	53
	105	133	119	101	88	77	70	64	60	56	53
	110	127	119	101	88	77	70	64	60	56	53
	120	117	116	99	88	77	70	64	60	56	53
	130	109	109	97	86	77	70	64	60	56	53
	140	101	101	95	85	77	70	64	60	56	53
	150	93	93	93	83	76	70	64	60	56	53
	160	81	81	81	81	75	69	64	60	56	53
	170	72	72	72	72	72	68	64	60	56	53

Notes – see page 11

Table 6 - MAXIMUM SPANS (inches) - Wind Zone 3											
XR100 Rail FlashFoot	Wind Speed	Ground Snow Load									
Exposure	mph	0 psf	10 psf	20 psf	30 psf	40 psf	50 psf	60 psf	70 psf	80 psf	90 psf
Category B	100	81	81	77	67	59	54	49	46	43	40
	105	78	78	77	67	59	54	49	46	43	40
	110	74	74	74	67	59	54	49	46	43	40
	120	68	68	68	67	59	54	49	46	43	40
	130	63	63	63	63	59	54	49	46	43	40
	140	59	59	59	59	59	54	49	46	43	40
	150	53	53	53	53	53	53	49	46	43	40
	160	47	47	47	47	47	47	47	46	43	40
Category C	100	69	69	69	67	59	54	49	46	43	40
	105	66	66	66	66	59	54	49	46	43	40
	110	63	63	63	63	59	54	49	46	43	40
	120	58	58	58	58	58	54	49	46	43	40
	130	50	50	50	50	50	50	49	46	43	40
	140	43	43	43	43	43	43	43	43	43	40
	150	38	38	38	38	38	38	38	38	38	38
	160	33	33	33	33	33	33	33	33	33	33
Category D	100	64	64	64	64	59	54	49	46	43	40
	105	61	61	61	61	59	54	49	46	43	40
	110	58	58	58	58	58	54	49	46	43	40
	120	50	50	50	50	50	50	49	46	43	40
	130	42	42	42	42	42	42	42	42	42	40
	140	37	37	37	37	37	37	37	37	37	37
	150	32	32	32	32	32	32	32	32	32	32
	160	28	28	28	28	28	28	28	28	28	28
	170	25	25	25	25	25	25	25	25	25	25

Notes – see page 11

Table 5 - MAXIMUM SPANS (inches) - Wind Zone 2											
XR100 Rail FlashFoot	Wind Speed	Ground Snow Load									
Exposure	mph	0 psf	10 psf	20 psf	30 psf	40 psf	50 psf	60 psf	70 psf	80 psf	90 psf
Category B	100	99	91	77	67	59	54	49	46	43	40
	105	95	91	77	67	59	54	49	46	43	40
	110	91	91	77	67	59	54	49	46	43	40
	120	84	84	77	67	59	54	49	46	43	40
	130	78	78	77	67	59	54	49	46	43	40
	140	72	72	72	67	59	54	49	46	43	40
	150	68	68	68	67	59	54	49	46	43	40
	160	64	64	64	64	59	54	49	46	43	40
	170	60	60	60	60	59	54	49	46	43	40
Category C	100	85	85	77	67	59	54	49	46	43	40
	105	81	81	77	67	59	54	49	46	43	40
	110	77	77	77	67	59	54	49	46	43	40
	120	71	71	71	67	59	54	49	46	43	40
	130	66	66	66	66	59	54	49	46	43	40
	140	61	61	61	61	59	54	49	46	43	40
	150	57	57	57	57	57	54	49	46	43	40
	160	51	51	51	51	51	51	49	46	43	40
	170	45	45	45	45	45	45	45	45	45	43
Category D	100	78	78	77	67	59	54	49	46	43	40
	105	75	75	75	67	59	54	49	46	43	40
	110	71	71	71	67	59	54	49	46	43	40
	120	66	66	66	66	59	54	49	46	43	40
	130	61	61	61	61	59	54	49	46	43	40
	140	56	56	56	56	56	54	49	46	43	40
	150	49	49	49	49	49	49	49	46	43	40
	160	43	43	43	43	43	43	43	43	43	40
	170	38	38	38	38	38	38	38	38	38	38

Notes – see page 11

Table 4 - MAXIMUM SPANS (inches) - Wind Zone 1											
XR100 Rail FlashFoot	Wind Speed	Ground Snow Load									
		0 psf	10 psf	20 psf	30 psf	40 psf	50 psf	60 psf	70 psf	80 psf	90 psf
Exposure	mph										
Category B	100	105	91	77	67	59	54	49	46	43	40
	105	105	91	77	67	59	54	49	46	43	40
	110	105	91	77	67	59	54	49	46	43	40
	120	105	91	77	67	59	54	49	46	43	40
	130	105	91	77	67	59	54	49	46	43	40
	140	98	91	77	67	59	54	49	46	43	40
	150	91	89	76	67	59	54	49	46	43	40
	160	86	86	75	67	59	54	49	46	43	40
Category C	100	105	91	77	67	59	54	49	46	43	40
	105	105	91	77	67	59	54	49	46	43	40
	110	104	91	77	67	59	54	49	46	43	40
	120	96	91	77	67	59	54	49	46	43	40
	130	89	89	76	67	59	54	49	46	43	40
	140	83	83	74	66	59	54	49	46	43	40
	150	78	78	73	65	59	54	49	46	43	40
	160	73	73	71	64	58	54	49	46	43	40
Category D	100	105	91	77	67	59	54	49	46	43	40
	105	101	91	77	67	59	54	49	46	43	40
	110	97	91	77	67	59	54	49	46	43	40
	120	89	88	76	67	59	54	49	46	43	40
	130	82	82	74	66	59	54	49	46	43	40
	140	77	77	72	65	59	54	49	46	43	40
	150	72	72	70	63	58	54	49	46	43	40
	160	68	68	68	62	57	53	49	46	43	40
170	64	64	64	61	56	52	49	46	43	40	

Notes – see page 11

Table 3 - MAXIMUM SPANS (inches) - Wind Zone 3											
XR10 Rail Flash Foot	Wind Speed	Ground Snow Load									
Exposure	mph	0 psf	10 psf	20 psf	30 psf	40 psf	50 psf	60 psf	70 psf	80 psf	90 psf
Category B	100	55	55	51	45	40	36	33	30	29	27
	105	52	52	51	45	40	36	33	30	29	27
	110	50	50	50	45	40	36	33	30	29	27
	120	46	46	46	45	40	36	33	30	29	27
	130	42	42	42	42	40	36	33	30	29	27
	140	39	39	39	39	39	36	33	30	29	27
	150	37	37	37	37	37	36	33	30	29	27
	160	34	34	34	34	34	34	33	30	29	27
Category C	170	32	32	32	32	32	32	32	30	29	27
	100	46	46	46	45	40	36	33	30	29	27
	105	44	44	44	44	40	36	33	30	29	27
	110	42	42	42	42	40	36	33	30	29	27
	120	39	39	39	39	39	36	33	30	29	27
	130	36	36	36	36	36	36	33	30	29	27
	140	33	33	33	33	33	33	33	30	29	27
	150	31	31	31	31	31	31	31	30	29	27
Category D	160	29	29	29	29	29	29	29	29	29	27
	170	27	27	27	27	27	27	27	27	27	27
	100	43	43	43	43	40	36	33	30	29	27
	105	41	41	41	41	40	36	33	30	29	27
	110	39	39	39	39	39	36	33	30	29	27
	120	36	36	36	36	36	36	33	30	29	27
	130	33	33	33	33	33	33	33	30	29	27
	140	31	31	31	31	31	31	31	30	29	27
Category D	150	28	28	28	28	28	28	28	28	28	27
	160	27	27	27	27	27	27	27	27	27	27
	170	25	25	25	25	25	25	25	25	25	25
	170	25	25	25	25	25	25	25	25	25	25

Notes – see page 11

Table 2 - MAXIMUM SPANS (inches) - Wind Zone 2											
XR10 Rail Flash Foot	Wind Speed	Ground Snow Load									
		0 psf	10 psf	20 psf	30 psf	40 psf	50 psf	60 psf	70 psf	80 psf	90 psf
Exposure	mph										
Category B	100	67	61	51	45	40	36	33	30	29	27
	105	64	61	51	45	40	36	33	30	29	27
	110	61	61	51	45	40	36	33	30	29	27
	120	56	56	51	45	40	36	33	30	29	27
	130	52	52	51	45	40	36	33	30	29	27
	140	49	49	49	45	40	36	33	30	29	27
	150	45	45	45	45	40	36	33	30	29	27
	160	43	43	43	43	40	36	33	30	29	27
Category C	100	57	57	51	45	40	36	33	30	29	27
	105	55	55	51	45	40	36	33	30	29	27
	110	52	52	51	45	40	36	33	30	29	27
	120	48	48	48	45	40	36	33	30	29	27
	130	44	44	44	44	40	36	33	30	29	27
	140	41	41	41	41	40	36	33	30	29	27
	150	38	38	38	38	38	36	33	30	29	27
	160	36	36	36	36	36	36	33	30	29	27
Category D	100	53	53	51	45	40	36	33	30	29	27
	105	50	50	50	45	40	36	33	30	29	27
	110	48	48	48	45	40	36	33	30	29	27
	120	44	44	44	44	40	36	33	30	29	27
	130	41	41	41	41	40	36	33	30	29	27
	140	38	38	38	38	38	36	33	30	29	27
	150	35	35	35	35	35	35	33	30	29	27
	160	33	33	33	33	33	33	33	30	29	27
	170	31	31	31	31	31	31	31	30	29	27

Notes – see page 11

Table 1 - MAXIMUM SPANS (inches) - Wind Zone 1											
XR10 Rail Flash Foot	Wind Speed	Ground Snow Load									
Exposure	mph	0 psf	10 psf	20 psf	30 psf	40 psf	50 psf	60 psf	70 psf	80 psf	90 psf
Category B	100	70	61	51	45	40	36	33	30	29	27
	105	70	61	51	45	40	36	33	30	29	27
	110	70	61	51	45	40	36	33	30	29	27
	120	70	61	51	45	40	36	33	30	29	27
	130	70	61	51	45	40	36	33	30	29	27
	140	66	61	51	45	40	36	33	30	29	27
	150	62	60	51	45	40	36	33	30	29	27
	160	58	58	50	45	40	36	33	30	29	27
Category C	170	55	55	49	44	40	36	33	30	29	27
	100	70	61	51	45	40	36	33	30	29	27
	105	70	61	51	45	40	36	33	30	29	27
	110	70	61	51	45	40	36	33	30	29	27
	120	65	61	51	45	40	36	33	30	29	27
	130	60	59	51	45	40	36	33	30	29	27
	140	56	56	49	44	40	36	33	30	29	27
	150	53	53	48	43	39	36	33	30	29	27
Category D	160	49	49	47	43	39	36	33	30	29	27
	170	46	46	46	42	38	35	33	30	29	27
	100	70	61	51	45	40	36	33	30	29	27
	105	68	61	51	45	40	36	33	30	29	27
	110	65	61	51	45	40	36	33	30	29	27
	120	60	59	50	45	40	36	33	30	29	27
	130	56	56	49	44	40	36	33	30	29	27
	140	52	52	48	43	39	36	33	30	29	27
150	48	48	47	42	39	36	33	30	29	27	
160	45	45	45	41	38	35	33	30	29	27	
170	43	43	43	40	37	35	33	30	29	27	

Notes – see page 11



Starling Madison Lofquist, Inc.
Consulting Structural and Forensic Engineers

5224 South 39th Street, Phoenix, Arizona 85040
tel: (602) 438-2500 fax: (602) 438-2505 ROC#291316 www.smleng.com

IronRidge
1495 Zephyr Ave
Hayward, CA 94544

December 18, 2014
page 1 of 11

Attn: Mr. David F. Taggart, Vice President Products

Subject: IronRidge FlashFoot

Dear Sir:

This letter is a supplement to the standard letter for the IronRidge Roof Flush Mounting System to address the requirements for use with the IronRidge FlashFoot.

The IronRidge FlashFoot comprises an aluminum block and flashing plate. An L-Foot base is attached using a 5/16" lag screw with a 3 inch minimum embedment into a wood substrate. The wood substrate for the tests consisted of 1/2" CDX plywood over a 2x6 SPF #2 rafter with a specific gravity of 0.42. A full detail can be seen on the attached drawings.

The testing data provided shows that the critical failure occurs in one of two ways, pullout of the lag screw from the base material or the shear failure of the L-Foot. Maximum allowable values for these failure conditions were derived using a safety factor of 3.0 on the lowest ultimate load provided by the testing. The maximum allowable uplift reaction of 717 lbs and the maximum allowable downslope (lateral) reaction of 341 lbs are based on the tested criteria.

The allowable loads used to develop the tables below have been increased from the tested values above to reflect installation into a wood substrate with specific gravity of 0.50. The increase was determined using the ANSI/AF&PA NDS-2010 National Design Specification (NDS) for Wood Construction adjustment factor of $1 / 1 - (0.50 - G)$ where G is the tested specific gravity. Therefore, the maximum allowable uplift reaction is 779 lbs and the maximum allowable downslope (lateral) reaction is 370 lbs. The maximum allowable spacing of the FlashFoot for common load cases due to wind and snow are shown in Tables 1-9 below.

2) Washer, EPDM backed

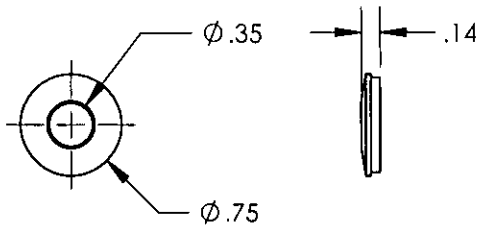

Property	Value
Material	Steel
Finish	Hot-Dip Galvanized

3) Bolt, 3/8-16 x 1" Hex CS SS

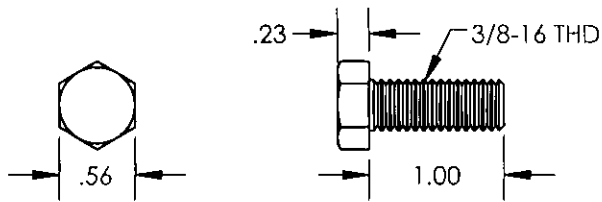

Property	Value
Material	Stainless Steel
Finish	Clear

4) Nut, Flange Hex 3/8-16 SS

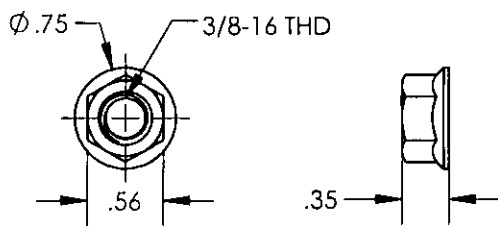

Property	Value
Material	Stainless Steel
Finish	Clear

5) Foot-L, Adjustable Extruded

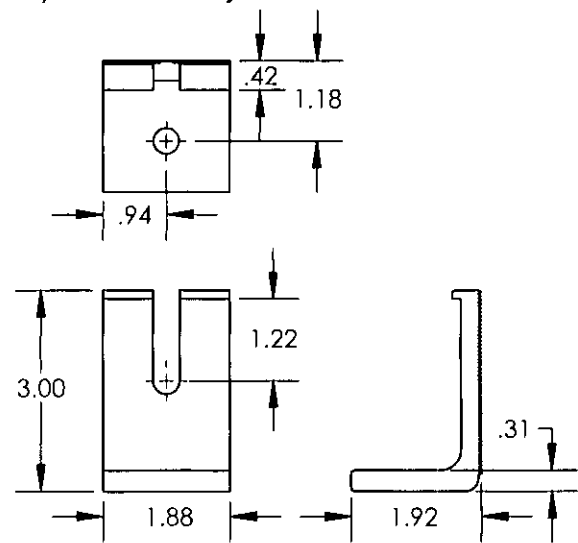

Property	Value
Material	Aluminum
Finish	Mill / Black

6) IR-GF-Flashing

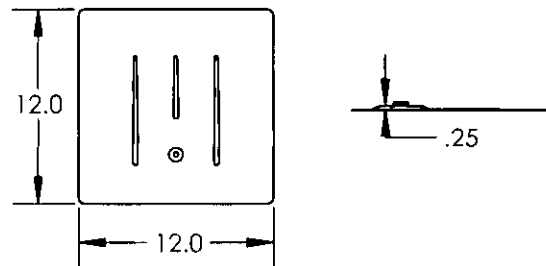

Property	Value
Material	Aluminum
Finish	Mill / Black

7) IR-GF-Support

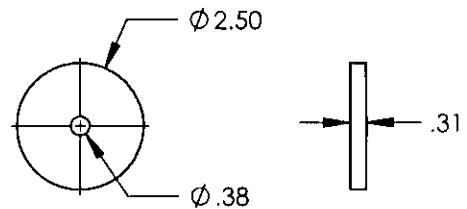

Property	Value
Material	Aluminum
Finish	Mill

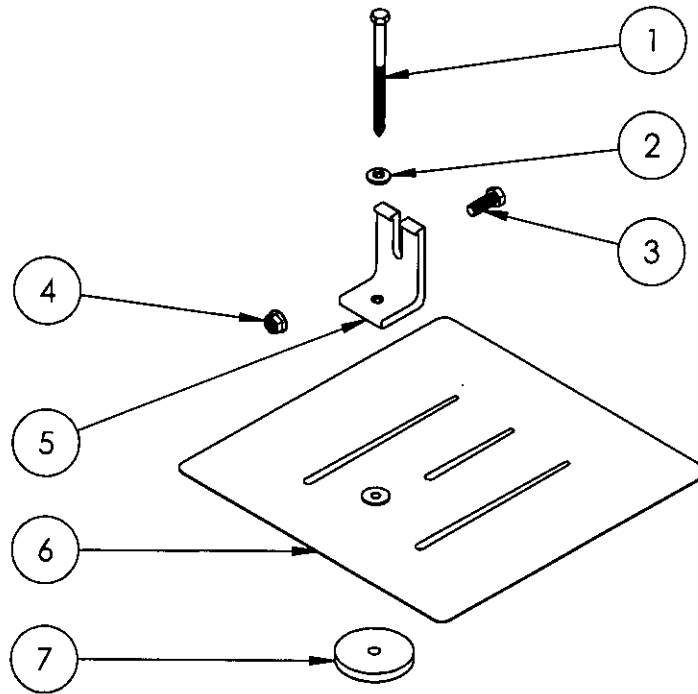

Item Number	Description	Qty In Kit
1	BOLT LAG 5/16 X 4.5"	6
2	WASHER, EPDM BACKED	6
3	BOLT, 3/8-16 X 1" HEX CS SS	6
4	NUT, FLANGE HEX 3/8-16 SS	6
5	FOOT-L, ADJUSTABLE EXTRUDED	6
6	IR-GF-FLASHING	6
7	IR-GF-SUPPORT	6

Part Number	Description
RF-FLSH-001	Kit, 6-Pack, IronRidge FlashFoot (Mill) (L-foot included)
RF-FLSH-001B	Kit, 6-Pack, IronRidge FlashFoot (Black) (L-foot included)

1) Bolt Lag 5/16 X 4.5"

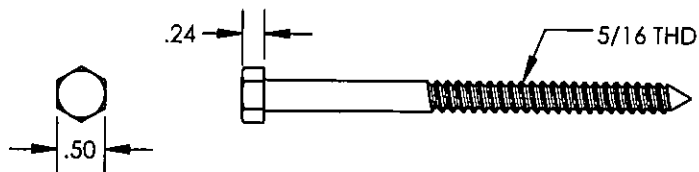

Property	Value
Material	Stainless Steel
Finish	Clear

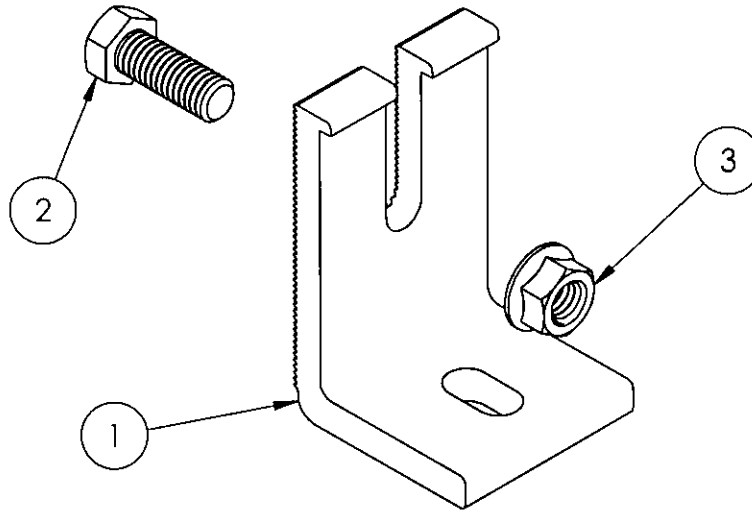

Item Number	Component	Qty in Kit
1	FOOT, EXTRUDED L - SLOTTED	4
2	BOLT, 3/8-16 X 1" HEX CS SS	4
3	NUT, FLANGE HEX 3/8-16 SS	4

Part Number	Description
RS-LFT-001	Kit of 4, Slotted L-Foot (Mill Finish)
RS-LFT-001B	Kit of 4, Slotted L-Foot (Black Finish)

1) Foot, Extruded L - Slotted

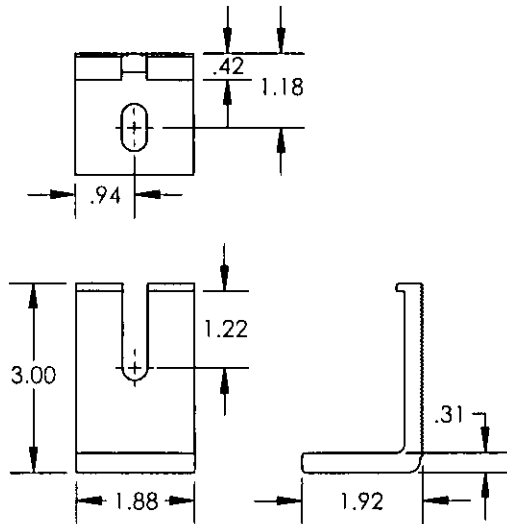

Property	Value
Material	Aluminum
Finish	Mill / Black

2) Bolt, 3/8-16 x 1" Hex CS SS

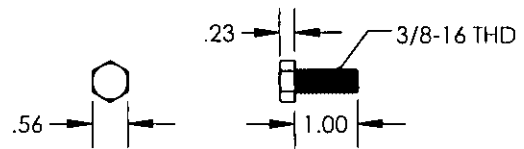

Property	Value
Material	Stainless Steel
Finish	Clear

3) Nut, Flange Hex 3/8-16 SS

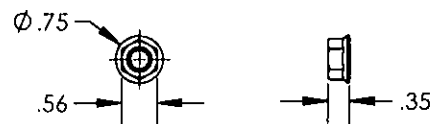

Property	Value
Material	Stainless Steel
Finish	Clear

2) Bolt, T Cstm 1/4-20

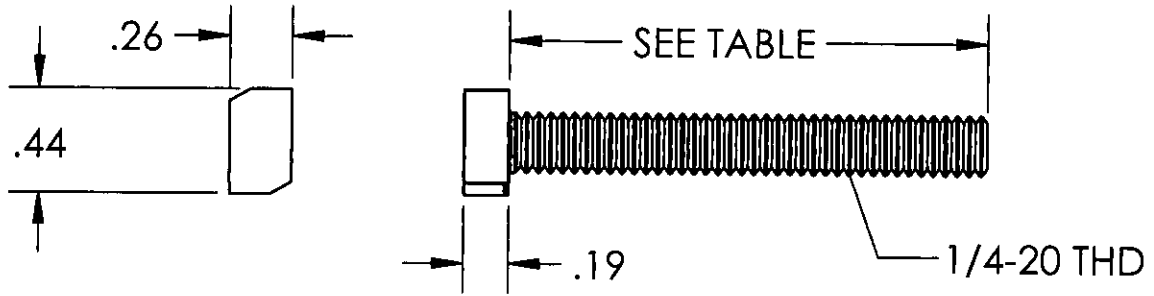

Property	Value
Material	300 Series Stainless Steel
Finish	Clear

3) Nut, Flange Hex 1/4-20 SST

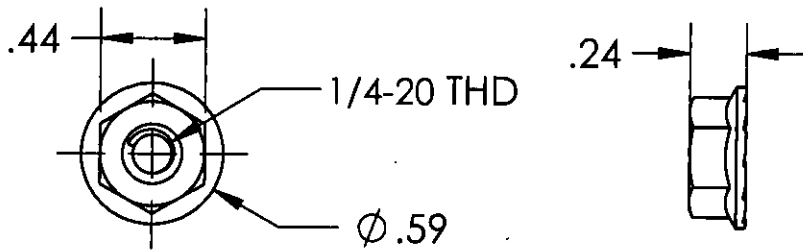

Property	Value
Material	300 Series Stainless Steel
Finish	Clear

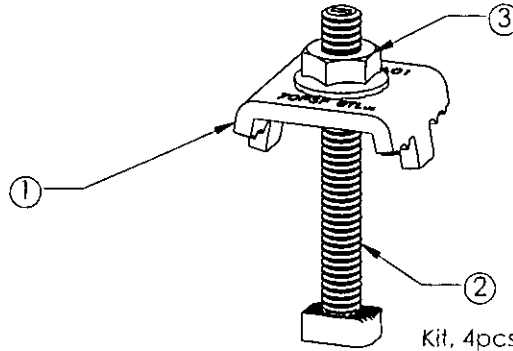

Kit, 4pcs. Grounding Mid Clamp

Item Number	Component	Qty in Kit
1	Clamp, Grounding Mid	4
2	Bolt, T Cstm 1/4-20	4
3	Nut, Flange Hex 1/4-20 SST	4

Kit, 4pcs. Grounding Mid Clamp

Clear Part Number	Black Part Number	Description / Length	Bolt Length
RS-GD-MCL-200	RS-GD-MCL-200B	Kit, 4pcs, Grounding Mid Clamp 2.00"	2.00"
RS-GD-MCL-225	RS-GD-MCL-225B	Kit, 4pcs, Grounding Mid Clamp 2.25"	2.25"
RS-GD-MCL-250	RS-GD-MCL-250B	Kit, 4pcs, Grounding Mid Clamp 2.50"	2.50"
RS-GD-MCL-275	RS-GD-MCL-275B	Kit, 4pcs, Grounding Mid Clamp 2.75"	2.75"

1) Integrated Grounding Mid Clamp

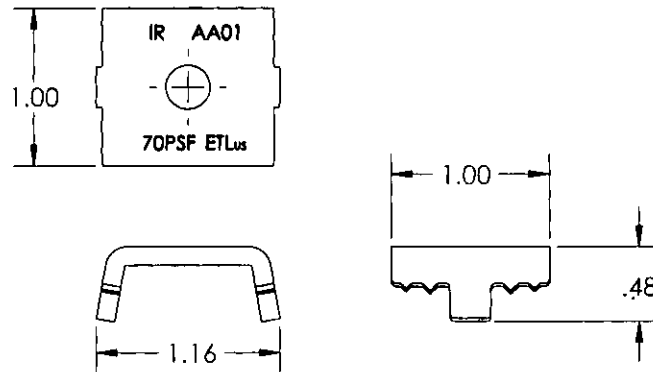

Property	Value
Material	300 Series Stainless Steel
Finish	CLEAR

1) Clamp, End

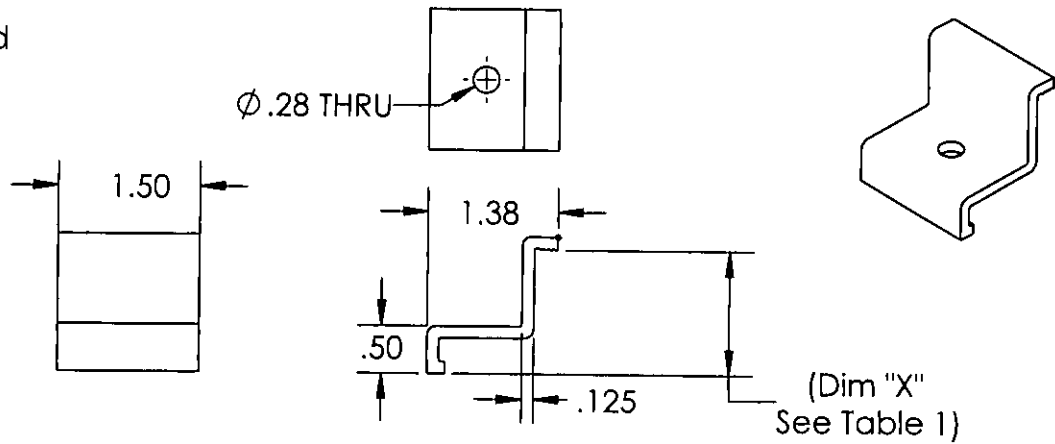

Property	Value
Material	6000-Series Aluminum
Finish	See Table 1 (Mill / Black)

2) BOLT, 1/4-20 X 1.00" HEX CS SST

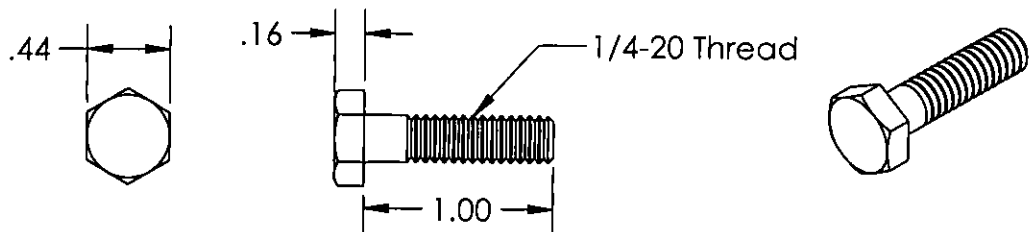

Property	Value
Material	300 Series Stainless Steel
Finish	See Table 1 (Mill / Black)

3) Nut, Flange Hex 1/4-20 SST

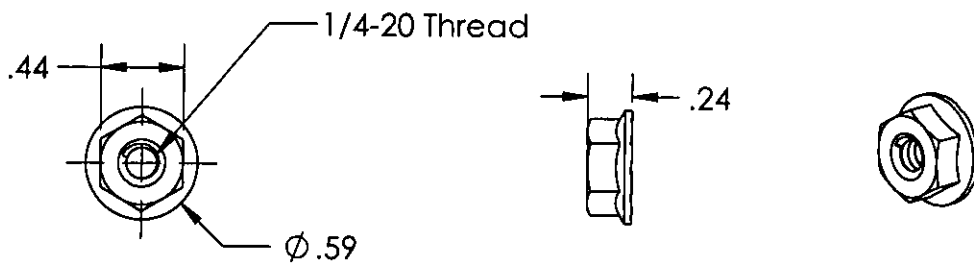

Property	Value
Material	300 Series Stainless Steel
Finish	See Table 1 (Mill / Black)

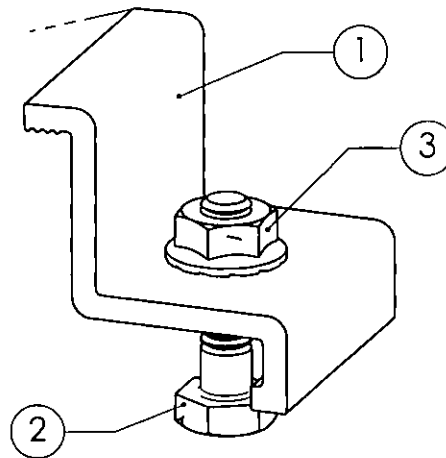

KIT, 4 PCS, END CLAMP

Item Number	Component	Qty in Kit
1	Clamp, End	4
2	Bolt, 1/4-20 X 1.00	4
3	Nut, Flange Hex 1/4-20 SST	4

TABLE 1: END CLAMP PART NUMBERS AND HEIGHT

MILL PART NUMBER	BLACK PART NUMBER	HEIGHT "X" in [mm]	ALLOWABLE MODULE THICKNESS in [mm]
29-7000-125	29-7000-125B	1.25 [32]	1.22 - 1.28 [31.0 - 32.5]
29-7000-130	29-7000-130B	1.30 [33]	1.28 - 1.32 [32.5 - 33.5]
29-7000-134	29-7000-134B	1.34 [34]	1.31 - 1.37 [33.3 - 34.8]
29-7000-224	29-7000-224B	1.41 [36]	1.37 - 1.45 [34.8 - 36.8]
29-7000-150	29-7000-150B	1.50 [38]	1.48 - 1.46 [37.5 - 38.5]
29-7000-157	29-7000-157B	1.57 [40]	1.53 - 1.61 [39.0 - 41.0]
29-7000-165	29-7000-165B	1.65 [42]	1.62 - 1.68 [41.1 - 42.7]
29-7000-171	29-7000-171B	1.71 [43]	1.68 - 1.74 [41.1 - 42.7]
29-7000-214	29-7000-214B	1.81 [46]	1.77 - 1.85 [45.0 - 47.0]
29-7000-187	29-7000-187B	1.875 [48]	1.84 - 1.90 [46.7 - 48.3]
29-7000-204	29-7000-204B	1.97 [50]	1.93 - 2.01 [49.0 - 51.1]
29-7000-230	29-7000-230B	2.30 [58]	2.26 - 2.32 [57.4 - 58.9]

Test Verification of Conformity

In the basis of the tests undertaken, the sample(s) of the below product have been found to comply with the requirements of the referenced specifications at the time the tests were carried out.

Applicant Name & Address:	IronRidge, Inc. 1495 Zephyr Ave. Hayward, CA 94544 USA
Product Description:	XR Rails with Integrated Grounding.
Ratings & Principle Characteristics:	<u>Fire Class Resistance Rating:</u> -Flush Mount (Symmetrical). Class A Fire Rated for Low Slope applications when using Type 1, 2 and 3, listed photovoltaic modules. Class A Fire Rated for Steep Slope applications with Type1, 2 and 3, listed photovoltaic modules. Tested with a 5" gap (distance between the bottom the module frame and the roof covering), per the standard this system can be installed at any gap allowed by the manufacturers installation instructions. No perimeter guarding is required.
Models:	51-61GD-005, 51-61GD-005B, 51-5000-001 and 51-65-001
Brand Name:	IronRidge Roof Mount
Relevant Standards:	UL 2703 (Section 15.2 and 15.3) Standard for Safety Mounting Systems, Mounting Devices, Clamping/Retention Devices, and Ground Lugs for Use with Flat-Plate Photovoltaic Modules and Panels, First Edition dated Jan. 28; 2015 Referencing UL1703 Third Edition dated Nov. 18, 2014, (Section 31.2) Standard for Safety for Flat-Plate Photovoltaic Modules and Panels.
Verification Issuing Office:	Intertek Testing Services NA, Inc. 8431 Murphy Drive Middleton, WI 53562
Date of Tests:	08/27/2014 to 03/17/2015
Test Report Number(s):	101769343MID-001r1, 101769343MID-001a, 101915978MID-001 & 101999492MID-001ar1-cr1.

This verification is part of the full test report(s) and should be read in conjunction with them. This report does not automatically imply product certification.

Completed by: Chad Naggs
Title: Technician II, Fire Resistance
Signature: 
Date: 03/30/2015

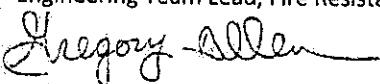
Reviewed by: Gregory Allen
Title: Engineering Team Lead, Fire Resistance
Signature: 
Date: 03/30/2015

This Verification is for the exclusive use of Intertek's client and is provided pursuant to the agreement between Intertek and its Client. Intertek's responsibility and liability are limited to the terms and conditions of the agreement. Intertek assumes no liability to any party, other than to the Client in accordance with the agreement, for any loss, expense or damage occasioned by the use of this Verification. Only the Client is authorized to permit copying or distribution of this Verification. Any use of the Intertek name or one of its marks for the sale or advertisement of the tested material, product or service must first be approved in writing by Intertek. The observations and test/inspection results referenced in this Verification are relevant only to the sample tested/inspected. This Verification by itself does not imply that the material, product, or service is or has ever been under an Intertek certification program.

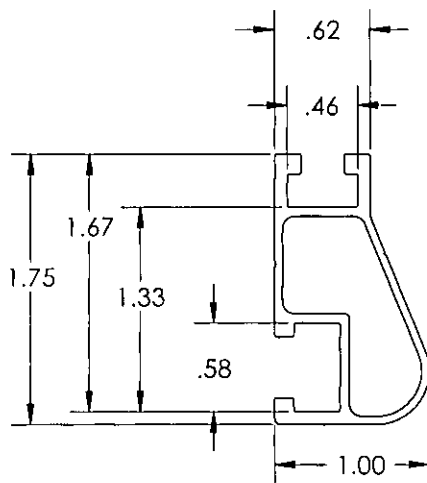
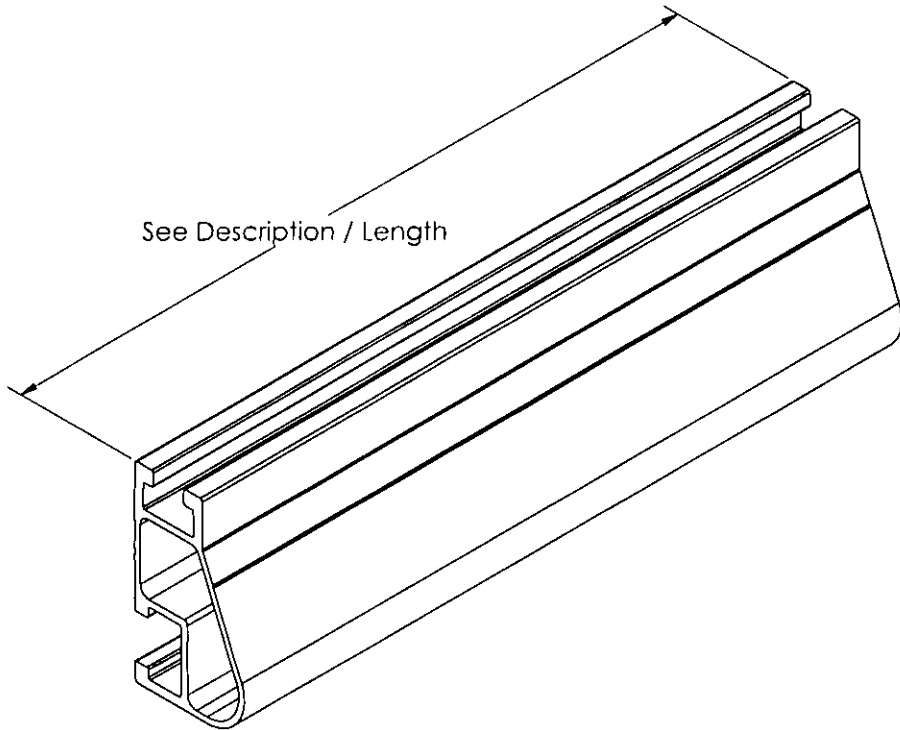

Rail Section Properties	
Property	Value
Total Cross-Sectional Area	0.363 in ²
Section Modulus (X-axis)	0.136 in ³
Moment of Inertia (X-axis)	0.124 in ⁴
Moment of Inertia (Y-axis)	0.032 in ⁴
Torsional Constant	0.076 in ³
Polar Moment of Inertia	0.033 in ⁴

Clear Part Number	Black Part Number	Description / Length	Material	Weight
XR-10-132A	XR-10-132B	XR10, Rail 132" (11 Feet)	6000-Series Aluminum	4.67 lbs.
XR-10-168A	XR-10-168B	XR10, Rail 168" (14 Feet)		5.95 lbs.
XR-10-204A	XR-10-204B	XR10, Rail 204" (17 Feet)		7.22 lbs.

XR Rail Family

The XR Rail Family offers the strength of a curved rail in three targeted sizes. Each size supports specific design loads, while minimizing material costs. Depending on your location, there is an XR Rail to match.

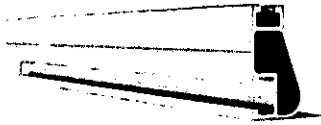

XR10

XR10 is a sleek, low-profile mounting rail, designed for regions with light or no snow. It achieves 6 foot spans, while remaining light and economical.

- 6' spanning capability
- Moderate load capability
- Clear anodized finish
- Internal splices available

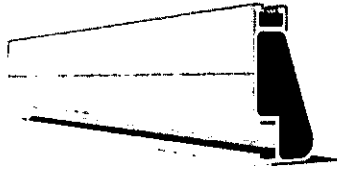

XR100

XR100 is the ultimate residential mounting rail. It supports a range of wind and snow conditions, while also maximizing spans up to 8 feet.

- 8' spanning capability
- Heavy load capability
- Clear & black anodized finish
- Internal splices available

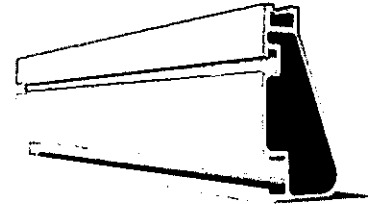

XR1000

XR1000 is a heavyweight among solar mounting rails. It's built to handle extreme climates and spans 12 feet or more for commercial applications.

- 12' spanning capability
- Extreme load capability
- Clear anodized finish
- Internal splices available

Rail Selection

The following table was prepared in compliance with applicable engineering codes and standards. Values are based on the following criteria: ASCE 7-10, Roof Zone 1, Exposure B, Roof Slope of 7 to 27 degrees and Mean Building Height of 30 ft. Visit IronRidge.com for detailed span tables and certifications.

Load		Rail Span					
Snow (PSF)	Wind (MPH)	4'	5' 4"	6'	8'	10'	12'
None	100	XR10		XR100		XR1000	
	120						
	140						
	160						
10-20	100					XR1000	
	120						
	140						
	160						
30	100					XR1000	
	160						
40	100					XR1000	
	160						
50-70	160						
80-90	160						





XR Rail Family

Solar Is Not Always Sunny

Over their lifetime, solar panels experience countless extreme weather events. Not just the worst storms in years, but the worst storms in 40 years. High winds capable of ripping panels from a roof, and snowfalls weighing enough to buckle a panel frame.

XR Rails are the structural backbone preventing these results. They resist uplift, protect against buckling and safely and efficiently transfer loads into the building structure. Their superior spanning capability requires fewer roof attachments, reducing the number of roof penetrations and the amount of installation time.

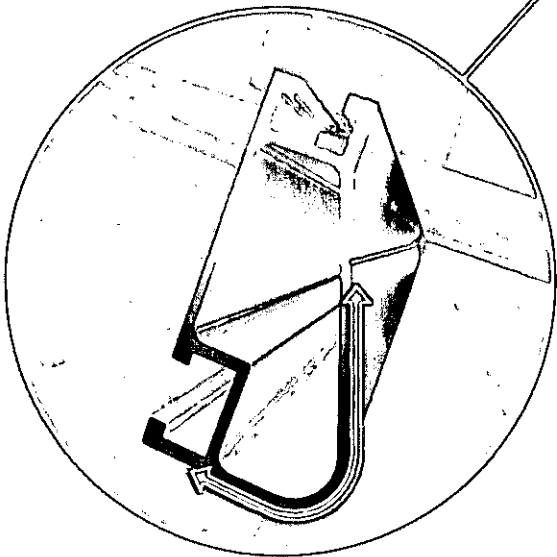
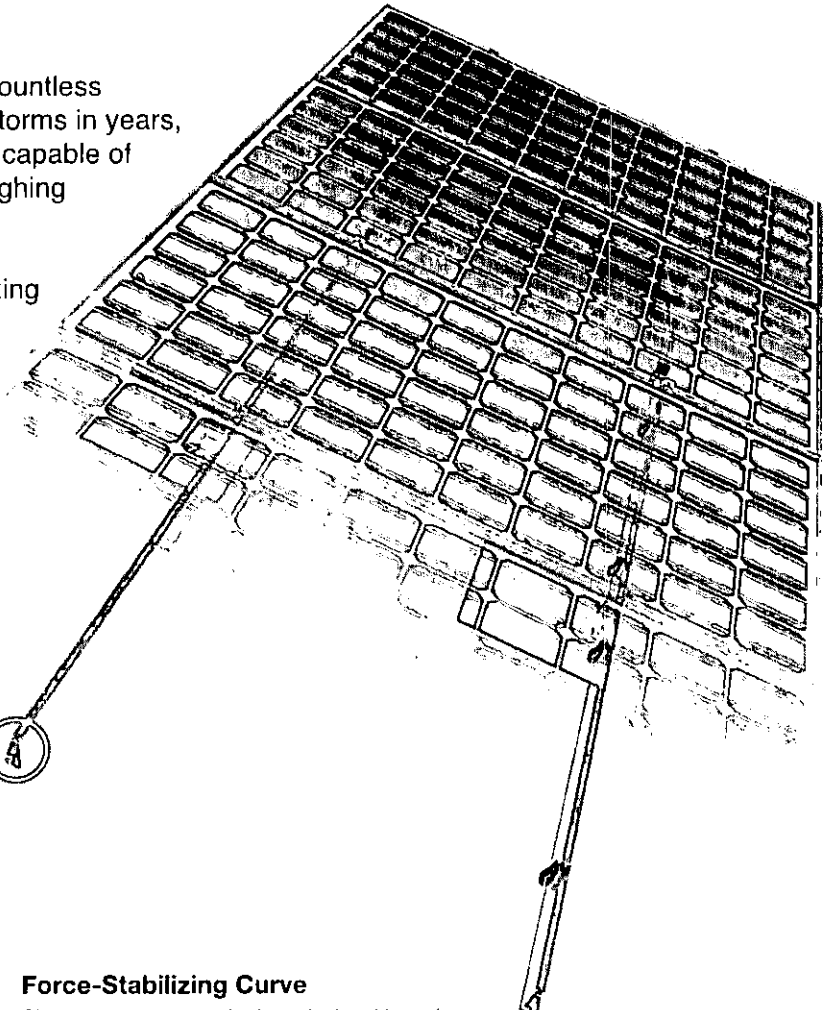

Force-Stabilizing Curve

Sloped roofs generate both vertical and lateral forces on mounting rails which can cause them to bend and twist. The curved shape of XR Rails is specially designed to increase strength in both directions while resisting the twisting. This unique feature ensures greater security during extreme weather and a longer system lifetime.

Compatible with Flat & Pitched Roofs



XR Rails are compatible with FlashFoot and other pitched roof attachments.



IronRidge offers a range of tilt leg options for flat roof mounting applications.

Corrosion-Resistant Materials

All XR Rails are made of marine-grade aluminum alloy, then protected with an anodized finish. Anodizing prevents surface and structural corrosion, while also providing a more attractive appearance.

