

Eagle 60M G2

305-325 Watt

MONO PERC MODULE

Positive power tolerance of 0- +3%

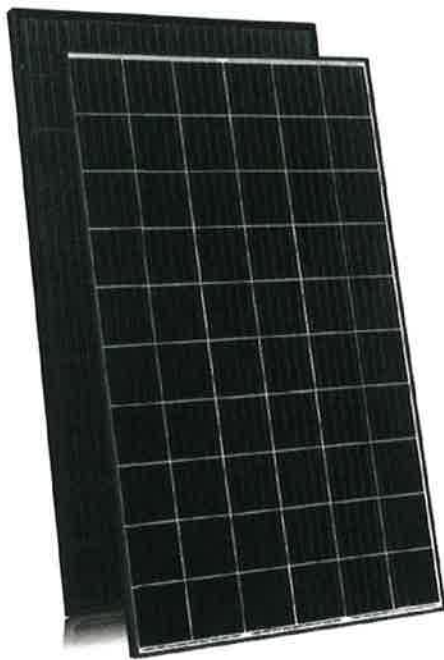
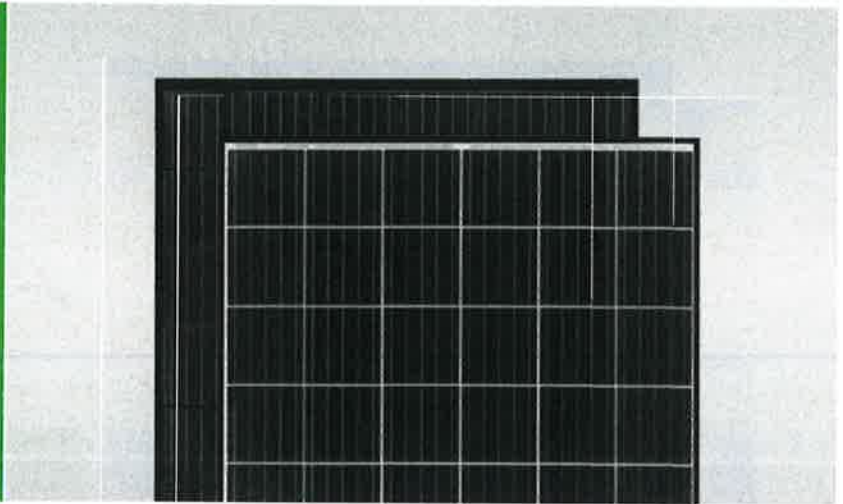

KEY FEATURES



Diamond Cell Technology

Uniquely designed high performance 5 busbar mono PERC cell



PID FREE

Reinforced cell prevents potential induced degradation



Better Low-Light Performance

Excellent performance in low-light environments



Strength and Durability

Certified for high snow (5400 Pa) and wind (2400 Pa) loads



Weather Resistance

Certified for salt mist and ammonia resistance

- ISO9001:2008 Quality Standards
- ISO14001:2004 Environmental Standards
- OHSAS18001 Occupational Health & Safety Standards
- IEC61215, IEC61730 certified products
- UL1703 certified products

Nomenclature:

JKM325M - 60BL

Code	Backsheet	Code	Cell
null	White	null	Normal
B	Black	L	Diamond



LINEAR PERFORMANCE WARRANTY

10 Year Product Warranty • 25 Year Linear Power Warranty

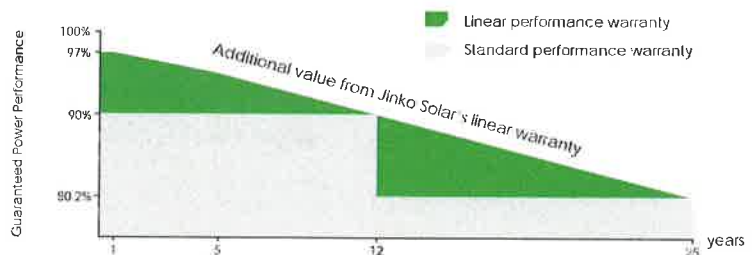

Engineering Drawings

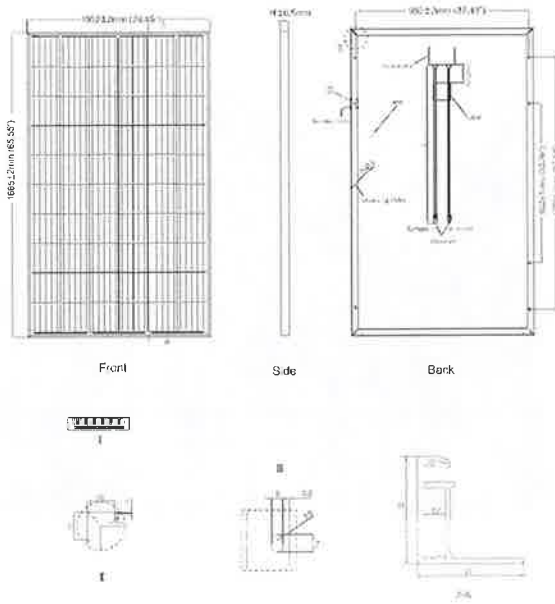

Packaging Configuration

[Two pallets - One stack]

30pcs/pallet, 60pcs/stack, 840pcs/40'HQ Container

Electrical Performance & Temperature Dependence

Current-Voltage & Power-Voltage Curves (310W)

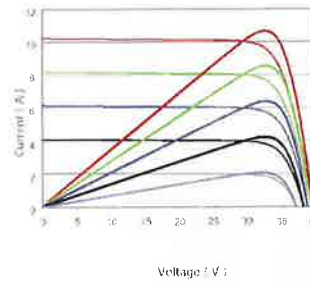

Temperature Dependence of Isc, Voc, Pmax

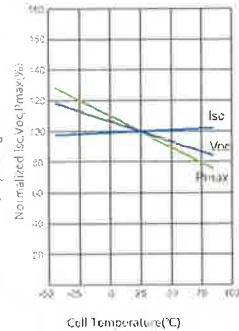

Mechanical Characteristics

Cell Type	Mono PERC Diamond Cell (158.75 x 158.75 mm)
No. of cells	60 (6 x 10)
Dimensions	1665 x 1002 x 35mm (65.55 x 39.45 x 1.38 inch)
Weight	19.0 kg (41.9 lbs)
Front Glass	3.2mm, Anti-Reflection Coating, High Transmission, Low Iron, Tempered Glass
Frame	Anodized Aluminium Alloy
Junction Box	IP67 Rated
Output Cables	12 AWG, Length 1000mm (39.37 in) or Customized Length
Fire Type	Type 1

SPECIFICATIONS

Module Type	JKM305M-60L		JKM310M-60L		JKM315M-60L		JKM320M-60L		JKM325M-60L	
	STC	NOCT	STC	NOCT	STC	NOCT	STC	NOCT	STC	NOCT
Maximum Power (Pmax)	305Wp	227Wp	310Wp	231Wp	315Wp	235Wp	320Wp	239Wp	325Wp	242Wp
Maximum Power Voltage (Vmp)	32.8V	30.8V	33.0V	31.0V	33.2V	31.2V	33.4V	31.4V	33.6V	31.6V
Maximum Power Current (Imp)	9.30A	7.40A	9.40A	7.49A	9.49A	7.56A	9.59A	7.62A	9.68A	7.66A
Open-circuit Voltage (Voc)	40.3V	37.2V	40.5V	37.4V	40.7V	37.6V	40.9V	37.8V	41.1V	38.0V
Short-circuit Current (Isc)	9.83A	8.12A	9.92A	8.20A	10.04A	8.33A	10.15A	8.44A	10.20A	8.54A
Module Efficiency STC (%)	18.28%		18.58%		18.88%		19.18%		19.48%	
Operating Temperature (°C)	-40°C ~ +85°C									
Maximum System Voltage	1000VDC(UL)/1000VDC(IEC)									
Maximum Series Fuse Rating	20A									
Power Tolerance	0 ~ +3%									
Temperature Coefficients of Pmax	-0.37%/°C									
Temperature Coefficients of Voc	-0.28%/°C									
Temperature Coefficients of Isc	0.048%/°C									
Nominal Operating Cell Temperature (NOCT)	45±2°C									

STC: ☀ Irradiance 1000W/m² 🌡 Cell Temperature 25°C ☁ AM=1.5

NOCT: ☀ Irradiance 800W/m² 🌡 Ambient Temperature 20°C ☁ AM=1.5 🌪 Wind Speed 1m/s

* Power measurement tolerance: ± 3%

CAUTION: READ SAFETY AND INSTALLATION INSTRUCTIONS BEFORE USING THE PRODUCT.

© Jinko Solar Co., Ltd. All rights reserved. Specifications included in this datasheet are subject to change without notice.
JKM305-325M-60L-A1-US



RAIL-FREE RACKING
UTILIZES ECOFASTEN SOLAR'S PATENTED TECHNOLOGY





Contents

Pg. 1	Assets of Design Features System Components
Pg. 2	Rock-It 4.0 Mount Assembly Rock-It 4.0 Coupling Assembly
Pg. 3	Rock-It 4.0 Hybrid Mount Assembly Rock-It Clip SS Assembly Rock-It Clip 2.0 Assembly
Pg. 4	Array Layout GreenFasten Flashing Install
Pg. 5	Rock-It System 4.0 Install
Pg. 6	Ground Lug Install
Pg. 7	Rock-It Clip SS Install Rock-It Clip 2.0 Install
Pg. 8 -12	Standoff Spacing Tables Snow Load 0-20 psf Snow Load 21-30 psf Snow Load 31-40 psf Snow Load 41-50 psf Snow Load 51-60 psf
Pg. 13	Grounding Information Bonding Assembly and Bonding Path
Pg. 14	Thermal Expansion and Bonding Bracket Spacing Staggered Layout Cantilever
Pg. 15-%*	System Specifications Evaluated, Compatible Modules

ROCK-IT SYSTEM 4.0

Designed with the installer in mind.

EcoFasten Solar specializes in solar roof attachments that are fast and easy to install, straightforward, secure and cost-effective. EcoFasten offers a wide variety of standard products as well as custom solutions, for a one-stop source for all of your rooftop anchoring needs. Products are rigorously tested and approved above and beyond industry standards in-house and by third party agencies. EcoFasten's patented conical sealing system has been in service in the snow guard and solar industries for two decades.

Features

- New and improved design
- Fastest, easiest to level system on the market
- Integrated electrical bonding
- SIMPLE- only 4 components
- North-South adjustability
- Only one tool required (1/2" deep well socket)
- Vertical adjustment of 3"-4"

system components* - required

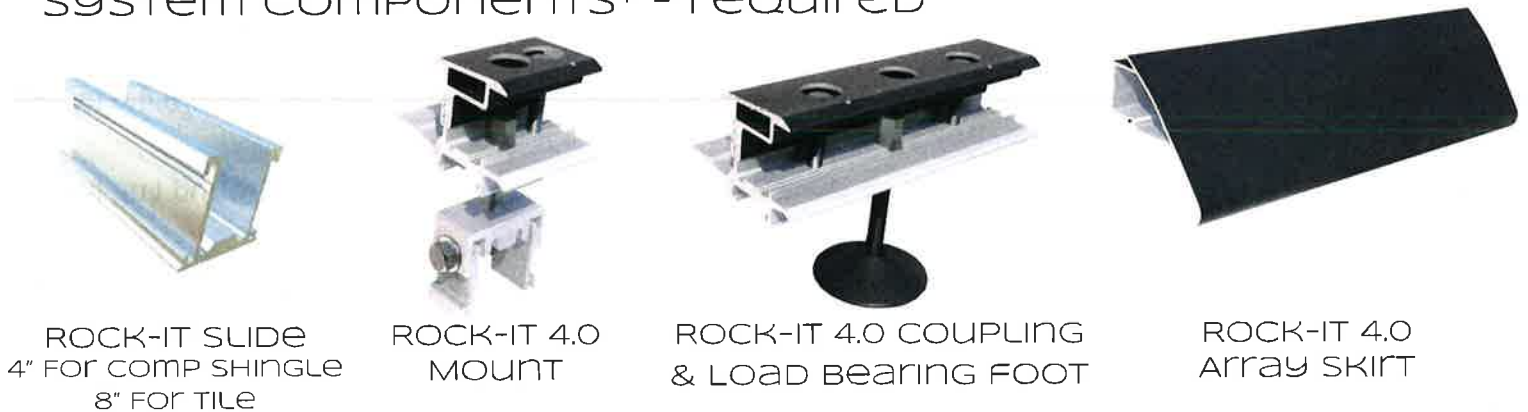

system components* - optional



EcoFasten Solar products are protected by the following U.S. Patents:

8,151,522 8,153,700 8,181,398 8,166,713 8,146,299
8,209,914 8,245,454 8,272,174 8,225,557 9,010,038
9,134,040 9,175,478 9,212,833

*Components for use with 32mm modules are available as special order. Components for use with 32mm modules are labeled as such on system packaging. Please refer to evaluated, compatible modules grid on page 15 to identify system compatible 32mm modules.

ROCK-IT 4.0 MOUNT ASSEMBLY

NOTE: ITEMS 1-7 SHIP ASSEMBLED

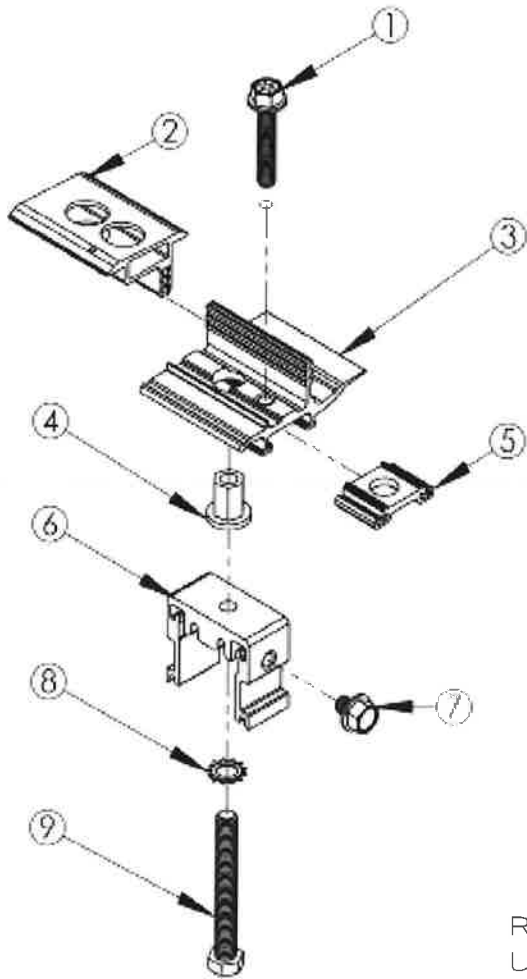

- 1 5/16"-18 x 1.75" Hex Serrated Flange Bolt 300 Series SS
- 2 Rock-It 4.0 Mid-Clamp 6000 Series AL
- 3 Rock-It 4.0 Shelf 6000 Series AL
- 4 Flange Level Nut 300 Series SS
- 5 Rock-It 4.0 Tie Plate 6000 Series AL
- 6 Rock-It Pedestal 6000 Series AL
- 7 5/16"-18 x 3/8" Hex Serrated Flange Bolt 300 Series SS
- 8 3/8" ID Star Washer 300 Series SS
- 9 3/8"-16 x 3" Hex Tap Bolt 300 Series SS

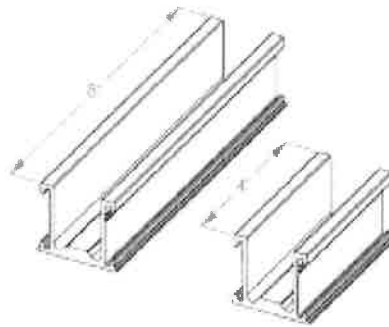

ROCK-IT SLIDES are acceptable brackets for use with ROCK-IT 4.0 (SOLD SEPARATELY)

ROCK-IT 4.0 COUPLING assembly

NOTE: ITEMS 1-3 SHIP ASSEMBLED

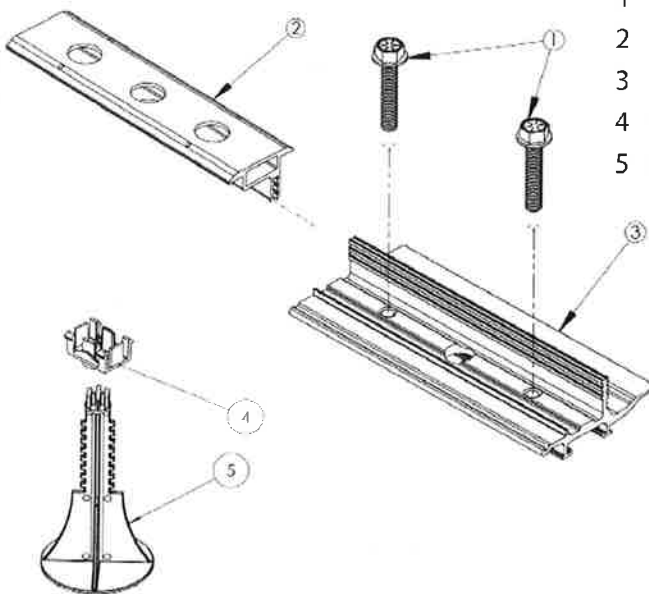

- 1 5/16"-18 x 1.75" Hex Serrated Flange Bolt 300 Series SS
- 2 Rock-It 4.0 Coupling Mid-Clamp 6000 Series AL
- 3 Rock-It 4.0 Coupling Shelf 6000 Series AL
- 4 Rock-It Load Bearing Foot Clip
- 5 Rock-It Load Bearing Foot Base

ROCK-IT 4.0 HYBRID MOUNT ASSEMBLY

NOTE: ITEMS 1-10 SHIP ASSEMBLED

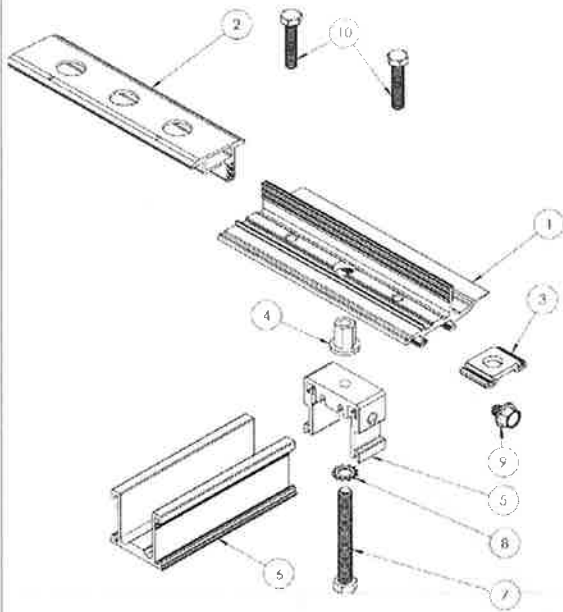

- 1 Rock-It 4.0 Shelf 6000 Series AL
- 2 Rock-It 4.0 Coupling Mid-Clamp 6000 Series AL
- 3 Rock-It 4.0 Coupling Tie Plate 6000 Series AL
- 4 Flange Level Nut 300 Series SS
- 5 Rock-It Pedestal 6000 Series AL
- 6 Rock-It Slide 6000 Series AL
- 7 3/8"-16 x 3" Hex Tap Bolt 300 Series SS
- 8 3/8" ID Star Washer 300 Series S
- 9 5/16"-18 x 3/8" Hex Serrated Flange Bolt 300 Series SS
- 10 5/16"-18 x 1.5" Hex Serrated Flange Bolt 300 Series SS

ROCK-IT CLIP SS ASSEMBLY

NOTE: ITEMS 1-3 SHIP ASSEMBLED

- 1 Stainless Steel Carriage Bolt - .313-18X.75
- 2 Rock-It Clip SS
- 3 Stainless Steel Flange nut .313-18

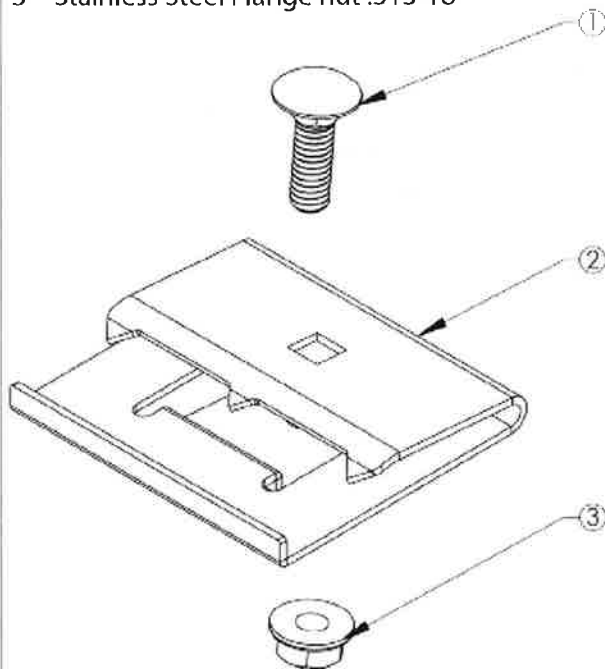

ROCK-IT CLIP 2.0 ASSEMBLY

NOTE: ITEMS 1-3 SHIP ASSEMBLED

- 1 Rock-It Clip 2.0
- 2 Stainless Steel Flange nut .313-18
- 3 Bolt .3125-18x1x1-5

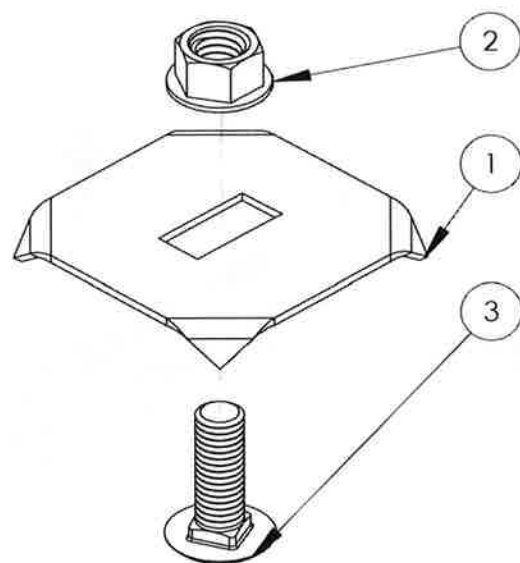

Array Layout

- Find the required structural attachment points. Mark these using a vertical (N-S) chalk line on the center of the rafters.
- Spacing may vary depending upon project specific structural requirements; i.e. high snow and wind load areas may require lesser bracket spacing in the E-W axis vs. the maximum spacing. Max spacing is 48" for portrait orientation and 72" for landscape orientation. Consult project layout diagram for project specific bracket spacing on the roof.
- Install Rock-It Mounts to predetermined mount spacing.
- The Rock-It Array Skirt sections are the width of a typical 60 cell module – use the Rock-It Array Skirt as a guide to lay out module placement.

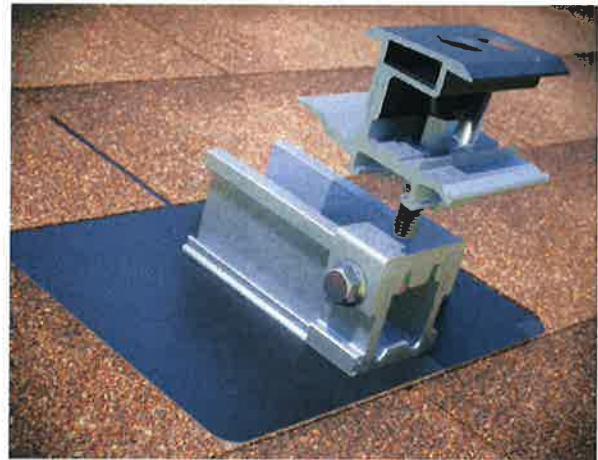

Note: The distance between the rows of mounts is calculated by the module dimension N-S plus 1 3/8" (35mm). Lag screw should be installed as close to center of exposed shingle as possible. The minimum distance between the lag screw and the edge of the shingle is 1/2".

GreenFASTEN™ FLASHING INSTALL

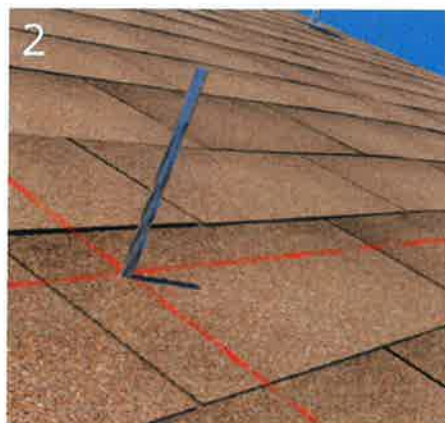

- 1 Locate the rafters and snap horizontal and vertical lines to mark the installation position for each GreenFasten flashing.
- 2 Drill a pilot hole (1/4" diameter) for the lag bolt. Backfill with sealant. EcoFasten Solar recommends an EPDM mastic.
- 3 Insert the flashing so the top part is under the next row of shingles and pushed far enough up slope to prevent water infiltration through vertical joint in shingles. The leading edge of flashing must butt against upper row of nails to prevent turning when torqued.
- 4 Line up pilot hole with GreenFasten flashing hole.

Insert the lag bolt through the EPDM bonded washer, the Rock-It slide, the gasketed hole in the flashing and into the rafter.

Torque: The range is between 100-140 torque inch-pounds depending on the type of wood and time of year. The visual indicator for proper torque is when the EPDM on the underside of the bonded washer begins to push out the sides as the washer compresses. If using an impact wrench to install the fasteners be careful not to over torque the fastener. You may need to stop and use a ratchet to finish the install.

*The Engineer of Record shall check capacity of rafter to support lag screw loading.

ROCK-IT SYSTEM 4.0 INSTALL

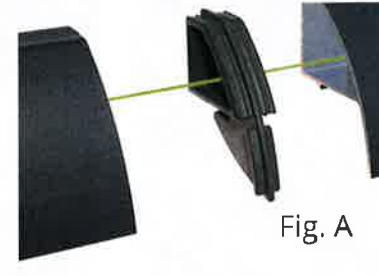

- 1 Install EcoFasten Solar Flashing with Rock-It Mounts
 - Follow EcoFasten Solar Install instructions for flashing and bracket install (GreenFasten shown above).
 - Optimum vertical distance between lag bolts is 1 3/8" plus module dimension.
 - Set mounts on eave most row so that the Rock-It Pedestal is on the South end of Rock-It Slide.
 - Set mounts on all upper rows so that the Rock-It Pedestal is on the North end of Rock-It Slide.
- 2 Install Rock-It Array Skirt onto Eave Mounts
 - Slide Rock-It Array Skirt into front channel on Rock-It Shelf.
 - Array Skirt End Caps are pre-installed on the East end of each skirt section, and are used to couple the skirt sections where needed (see Fig. A).
 - Tighten Mid-Clamp bolt, clamping Rock-It Array Skirt to mount. Torque to 200 in-lbs. (130 in-lbs. when installing with 32mm modules).
- 3-4 Install Rock-It Couplings (when joining 4 panels with a Coupling, the use of a load bearing foot is required)
 - Prior to mounting on the roof, snap Load Bearing Foot into the bottom of Rock-It Coupling if required. (Each Load Bearing Foot is set to same height as the Rock-It Mounts - adjust accordingly)
 - On eave row only, slide Rock-It Array Skirt onto Rock-It Coupling Shelf. Torque to specified value.
 - NOTE: If a coupling lands on a rafter, the Hybrid Mount* should be used in place of the Rock-It Coupling (refer to image 3a).
 - *Hybrid Mount can be made in the field by assembling a coupling to a mount pedestal, or by purchasing separately.
- 5 Align and Straighten First Row of the Rock-It System with Rock-It Array Skirt
 - Use North-South adjustment of the Rock-It Pedestal to straighten Rock-It Array Skirt and align module with Array Skirt.
 - Torque screw on side of Rock-It Pedestal to 150 in-lbs to secure it to the Rock-It Slide.
 - Adjust Flange Level Nut to level the system (optional – can be leveled during or after installation).
- 6-9 Install 1st Row of PV Modules
 - Slide upslope Rock-It Mounts down to engage top of first module.
 - Install Rock-It Couplings on the upslope side of 1st row of panels.
 - Torque 2nd row of Mid-Clamps on Rock-It Mounts and Rock-It Couplings to specified value.
 - Install balance of PV modules, ensuring that the Rock-It Pedestals are in the appropriate position, then torque Mid-Clamps to secure modules.
- 10 Level the Rock-It System
 - When assembly is complete, level the entire system by adjusting Flange Level Nuts (Flange Level Nuts have no torque value).
 - Height between roof surface and underside of modules should be 3" or less, when installed with Type 2 modules.

INSTALLATION NOTE: Modules should be installed so that the junction box is installed upslope, away from the leading edge of the array.

GROUNDING LUG INSTALL

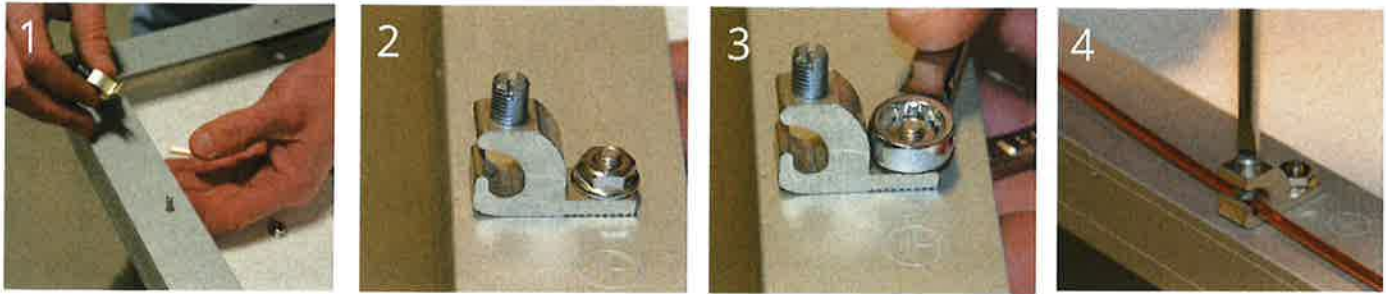

Necessary Components:

- One of the following ground lugs (or any UL 2703 compliant ground lug):
 - Burndy CL50-1TN Ground Lug (UL 2703 - E351343 / UL 467 - E9999)
 - ILSCO SGB-4 Ground Lug (UL 2703 - E354420 / UL 467 - E34440)
 - ILSCO GBL-4DBT (UL 2703 - E354420 / UL 467 - E34440)
 - ILSCO GBL-4DBTH (UL 2703 - E354420 / UL 467 - E34440)
 - ILSCO GBL-4SS (UL 2703 - E354420 / UL 467 - E34440)

Note: Drill and deburr hole in Ground Lug prior to installation

- | | |
|---------------------------------------------------------|-----------------------|
| - 14 AWG - 4 AWG Copper Ground Wire* | Torque Values: |
| - 8-32 x 0.5" Serrated Flange Head Bolt (300 Series SS) | 14-10 AWG= 20 in-lbs. |
| - 8-32 Serrated Flange Nut (300 Series SS) | 8 AWG= 25 in-lbs. |
| - 11/32" and 1/4" wrenches or ratchets/sockets | 6-4 AWG= 35 in-lbs. |
- 1 Insert the flange bolt into the module ground hole. Place Star Washer over bolt. Place ground lug over the bolt and Star Washer, and turn to desired orientation.
 - 2 Install Flange Nut.
 - 3 Tighten Flange Nut/Bolt.
 - 4 Place wire in Ground Lug channel and tighten set screw to complete assembly.
- *Wire should be sized in accordance with the National Electrical Code, NFPA 70, Section 690.45, and a minimum of 1/4" clearance required between bare copper wire and aluminum.



Drill hole per grounding lug manufacturers specifications in the upslope part of Rock-It Coupling for attaching grounding lug.

Note: Deburr hole in Ground Lug and Rock-It Coupling prior to installation.

ROCK-IT CLIP SS INSTALL

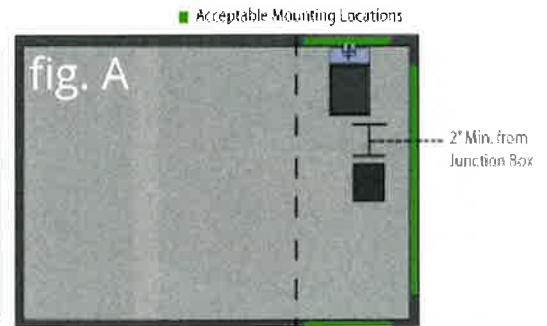

1 Locate all parts

- Locate the Rock-It Clip SS, micro-inverter/power optimizer, and the section of the module frame in which you will be mounting the micro-inverter/power optimizer.

See fig. A for acceptable mounting locations.

2 Install the Rock-It Clip SS

- Slide the Rock-It Clip SS onto the lip of the module frame.
- Slide the micro-inverter/power optimizer into the opposite lip of the Rock-It Clip SS.
- Tighten the bolt to 150 in-lb minimum to clamp the Rock-It Clip SS to the module frame and the micro-inverter/power optimizer to the Rock-It Clip SS.
- Ensure that the lip on the clip is tight against the frame and that the micro-inverter/power optimizer flange is tight against the clip flange to avoid rotation during tightening.

ROCK-IT CLIP 2.0 INSTALL

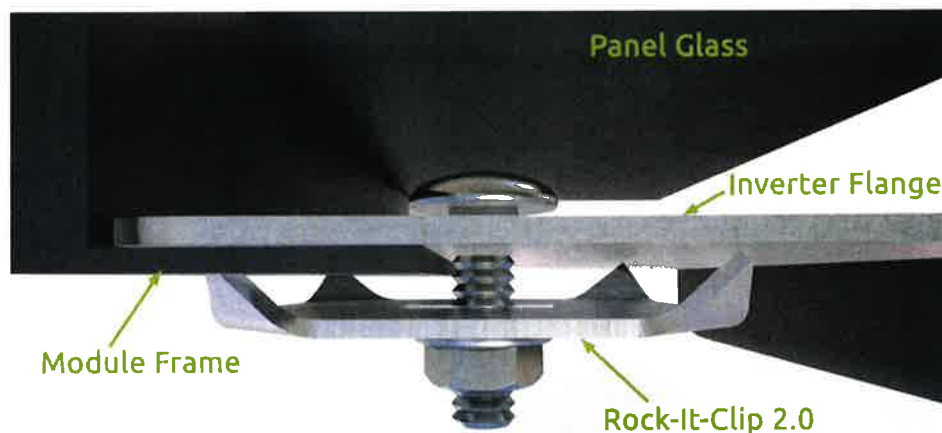

1 Locate all parts

- Locate the Rock-It Clip 2.0, micro-inverter/power optimizer, and the section of the module frame in which you will be mounting the micro-inverter/power optimizer.

2 Install the Rock-It Clip 2.0 (See below detail)

- Slide the Rock-It Clip 2.0 onto the lip of the micro-inverter/power optimizer.
- Slide the micro-inverter/power optimizer into the opposite lip of the module frame.
- Tighten the bolt to 150 in-lb to clamp the Rock-It Clip 2.0 to the module frame and the micro-inverter/power optimizer to the Rock-It Clip 2.0.
- Ensure that the lip on the clip is tight against the frame and that the micro-inverter/power optimizer flange is tight against the clip flange to avoid rotation during tightening.

Snow Load 0-20 psf

Modules in Landscape								
Wind Speed		Exposure Category	2:12 < Roof Pitch < 6:12			7:12 < Roof Pitch < 12:12		
ASCE 7-05	ASCE 7-10		Zone 1	Zone 2	Zone 3	Zone 1	Zone 2	Zone 3
85 mph	110 mph	B	159	93	59	103	103	103
		C	114	67	42	103	88	88
		D	96	56	35	91	74	74
90 mph	115 mph	B	146	85	54	103	103	103
		C	104	61	38	98	80	80
		D	88	51	32	83	68	68
100 mph	125 mph	B	123	72	45	103	95	95
		C	88	51	32	83	68	68
		D	74	43	27	70	57	57
110 mph	140 mph	B	98	57	36	93	76	76
		C	70	41	26	66	54	54
		D	59	34	22	56	46	46
120 mph	150 mph	B	85	50	31	81	66	66
		C	61	36	22	58	47	47
		D	51	30	19	49	40	40

Notes:

 Spacing Governed by Snow Load

- 1.) Values in above table represent the maximum allowable spacing in inches for pullout forces only on EcoFasten Solar standoff, however the designer must round down to meet appropriate rafter spacing
- 2.) Maximum allowed spacing approved by EcoFasten Solar is 72"
- 3.) Maximum allowed standoff capacity = 547# (per testing results)
- 4.) Includes additional factor of safety of 1.5 for lag pullout capacity
- 5.) Values based on a maximum module width of 40"
- 6.) Based on Risk Category II (ASCE 7-10) structures less than 30 feet in height
- 7.) All adjustment factors are set to 1. No site specific engineering is included in this table

Snow Load 0-20 psf

Modules in Portrait								
Wind Speed		Exposure Category	2:12 < Roof Pitch < 6:12			7:12 < Roof Pitch < 12:12		
ASCE 7-05	ASCE 7-10		Zone 1	Zone 2	Zone 3	Zone 1	Zone 2	Zone 3
85 mph	110 mph	B	91	53	33	62	62	62
		C	65	38	24	61	50	50
		D	55	32	20	52	42	42
90 mph	115 mph	B	83	49	30	62	62	62
		C	59	35	22	56	46	46
		D	50	29	18	47	38	38
100 mph	125 mph	B	70	41	26	62	54	54
		C	50	29	18	47	39	39
		D	42	26	15	40	32	32
110 mph	140 mph	B	56	33	20	53	43	43
		C	40	23	14	38	31	31
		D	34	19	12	32	26	26
120 mph	150 mph	B	49	28	18	46	37	37
		C	35	20	12	33	27	27
		D	29	17	10	28	22	22

Notes:

 Spacing Governed by Snow Load

- 1.) Values in above table represent the maximum allowable spacing in inches for pullout forces only on EcoFasten Solar standoff
- 2.) Maximum allowed spacing approved by EcoFasten Solar is 48"
- 3.) Maximum allowed standoff capacity = 547# (per testing results)
- 4.) Includes additional factor of safety of 1.5 for lag pullout capacity
- 5.) Values based on a maximum module length of 70"
- 6.) Based on Risk Category II (ASCE 7-10) structures less than 30 feet in height
- 7.) All adjustment factors are set to 1. No site specific engineering is included in this table

Snow Load 21-30 psf

Modules in Landscape								
Wind Speed		Exposure Category	2:12 < Roof Pitch < 6:12			7:12 < Roof Pitch < 12:12		
ASCE 7-05	ASCE 7-10		Zone 1	Zone 2	Zone 3	Zone 1	Zone 2	Zone 3
85 mph	110 mph	B	110	93	59	68	68	68
		C	110	67	42	68	68	68
		D	96	56	35	68	68	68
90 mph	115 mph	B	110	85	54	68	68	68
		C	104	61	38	68	68	68
		D	88	51	32	68	68	68
100 mph	125 mph	B	110	72	45	68	68	68
		C	88	51	32	68	68	68
		D	74	43	27	68	57	57
110 mph	140 mph	B	98	57	36	68	68	68
		C	70	41	26	66	54	54
		D	59	34	22	56	46	46
120 mph	150 mph	B	85	50	31	68	66	66
		C	61	36	22	58	47	47
		D	51	30	19	49	40	40

Notes:

Spacing Governed by Snow Load

- 1.) Values in above table represent the maximum allowable spacing in inches for pullout forces only on EcoFasten Solar standoff, however the designer must round down to meet appropriate rafter spacing
- 2.) Maximum allowed spacing approved by EcoFasten Solar is 72"
- 3.) Maximum allowed standoff capacity = 547# (per testing results)
- 4.) Includes additional factor of safety of 1.5 for lag pullout capacity
- 5.) Values based on a maximum module width of 40"
- 6.) Based on Risk Category II (ASCE 7-10) structures less than 30 feet in height
- 7.) All adjustment factors are set to 1. No site specific engineering is included in this table

Snow Load 21-30 psf

Modules in Portrait								
Wind Speed		Exposure Category	2:12 < Roof Pitch < 6:12			7:12 < Roof Pitch < 12:12		
ASCE 7-05	ASCE 7-10		Zone 1	Zone 2	Zone 3	Zone 1	Zone 2	Zone 3
85 mph	110 mph	B	66	53	33	41	41	41
		C	65	38	24	41	41	41
		D	55	32	20	41	41	41
90 mph	115 mph	B	66	49	30	41	41	41
		C	59	35	22	41	41	41
		D	50	29	18	41	38	38
100 mph	125 mph	B	66	41	26	41	41	41
		C	50	29	18	41	39	39
		D	42	26	15	40	32	32
110 mph	140 mph	B	56	33	20	41	41	41
		C	40	23	14	38	31	31
		D	34	19	12	32	26	26
120 mph	150 mph	B	49	28	18	41	37	37
		C	35	20	12	33	27	27
		D	29	17	10	28	22	22

Notes:

Spacing Governed by Snow Load

- 1.) Values in above table represent the maximum allowable spacing in inches for pullout forces only on EcoFasten Solar standoff
- 2.) Maximum allowed spacing approved by EcoFasten Solar is 48"
- 3.) Maximum allowed standoff capacity = 547# (per testing results)
- 4.) Includes additional factor of safety of 1.5 for lag pullout capacity
- 5.) Values based on a maximum module length of 70"
- 6.) Based on Risk Category II (ASCE 7-10) structures less than 30 feet in height
- 7.) All adjustment factors are set to 1. No site specific engineering is included in this table

Snow Load 31-40 psf

Modules in Landscape								
Wind Speed		Exposure Category	2:12 < Roof Pitch < 6:12			7:12 < Roof Pitch < 12:12		
ASCE 7-05	ASCE 7-10		Zone 1	Zone 2	Zone 3	Zone 1	Zone 2	Zone 3
85 mph	110 mph	B	83	83	59	51	51	51
		C	83	67	42	51	51	51
		D	83	56	35	51	51	51
90 mph	115 mph	B	83	83	54	51	51	51
		C	83	61	38	51	51	51
		D	83	51	32	51	51	51
100 mph	125 mph	B	83	72	45	51	51	51
		C	83	51	32	51	51	51
		D	74	43	27	51	51	51
110 mph	140 mph	B	83	57	36	51	51	51
		C	70	41	26	51	51	51
		D	59	34	22	51	46	46
120 mph	150 mph	B	83	50	31	51	51	51
		C	61	36	22	51	47	47
		D	51	30	19	49	40	40

Notes:

Spacing Governed by Snow Load

- 1.) Values in above table represent the maximum allowable spacing in inches for pullout forces only on EcoFasten Solar standoff, however the designer must round down to meet appropriate rafter spacing
- 2.) Maximum allowed spacing approved by EcoFasten Solar is 72"
- 3.) Maximum allowed standoff capacity = 547# (per testing results)
- 4.) Includes additional factor of safety of 1.5 for lag pullout capacity
- 5.) Values based on a maximum module width of 40"
- 6.) Based on Risk Category II (ASCE 7-10) structures less than 30 feet in height
- 7.) All adjustment factors are set to 1. No site specific engineering is included in this table

Snow Load 31-40 psf

Modules in Portrait								
Wind Speed		Exposure Category	2:12 < Roof Pitch < 6:12			7:12 < Roof Pitch < 12:12		
ASCE 7-05	ASCE 7-10		Zone 1	Zone 2	Zone 3	Zone 1	Zone 2	Zone 3
85 mph	110 mph	B	50	50	33	31	31	31
		C	50	38	24	31	31	31
		D	50	32	20	31	31	31
90 mph	115 mph	B	50	49	30	31	31	31
		C	50	35	22	31	31	31
		D	50	29	18	31	31	31
100 mph	125 mph	B	50	41	26	31	31	31
		C	50	29	18	31	31	31
		D	42	26	15	31	31	31
110 mph	140 mph	B	50	33	20	31	31	31
		C	40	23	14	31	31	31
		D	34	19	12	31	26	26
120 mph	150 mph	B	49	28	18	31	31	31
		C	35	20	12	31	27	27
		D	29	17	10	28	22	22

Notes:

Spacing Governed by Snow Load

- 1.) Values in above table represent the maximum allowable spacing in inches for pullout forces only on EcoFasten Solar standoff
- 2.) Maximum allowed spacing approved by EcoFasten Solar is 48"
- 3.) Maximum allowed standoff capacity = 547# (per testing results)
- 4.) Includes additional factor of safety of 1.5 for lag pullout capacity
- 5.) Values based on a maximum module length of 70"
- 6.) Based on Risk Category II (ASCE 7-10) structures less than 30 feet in height
- 7.) All adjustment factors are set to 1. No site specific engineering is included in this table

Snow Load 41-50 psf

Modules in Landscape								
Wind Speed		Exposure Category	2:12 < Roof Pitch < 6:12			7:12 < Roof Pitch < 12:12		
ASCE 7-05	ASCE 7-10		Zone 1	Zone 2	Zone 3	Zone 1	Zone 2	Zone 3
85 mph	110 mph	B	66	66	59	51	51	51
		C	66	66	42	51	51	51
		D	66	56	35	51	51	51
90 mph	115 mph	B	66	66	54	51	51	51
		C	66	61	38	51	51	51
		D	66	51	32	51	51	51
100 mph	125 mph	B	66	66	45	51	51	51
		C	66	51	32	51	51	51
		D	66	43	27	51	51	51
110 mph	140 mph	B	66	57	36	51	51	51
		C	66	41	26	51	51	51
		D	59	34	22	51	46	46
120 mph	150 mph	B	66	50	31	51	51	51
		C	61	36	22	51	47	47
		D	51	30	19	49	40	40

Notes:

Spacing Governed by Snow Load

- 1.) Values in above table represent the maximum allowable spacing in inches for pullout forces only on EcoFasten Solar standoff, however the designer must round down to meet appropriate rafter spacing
- 2.) Maximum allowed spacing approved by EcoFasten Solar is 72"
- 3.) Maximum allowed standoff capacity = 547# (per testing results)
- 4.) Includes additional factor of safety of 1.5 for lag pullout capacity
- 5.) Values based on a maximum module width of 40"
- 6.) Based on Risk Category II (ASCE 7-10) structures less than 30 feet in height
- 7.) All adjustment factors are set to 1. No site specific engineering is included in this table

Snow Load 41-50 psf

Modules in Portrait								
Wind Speed		Exposure Category	2:12 < Roof Pitch < 6:12			7:12 < Roof Pitch < 12:12		
ASCE 7-05	ASCE 7-10		Zone 1	Zone 2	Zone 3	Zone 1	Zone 2	Zone 3
85 mph	110 mph	B	40	40	33	25	25	25
		C	40	38	24	25	25	25
		D	40	32	20	25	25	25
90 mph	115 mph	B	40	40	30	25	25	25
		C	40	35	22	25	25	25
		D	40	29	18	25	25	25
100 mph	125 mph	B	40	40	26	25	25	25
		C	40	29	18	25	25	25
		D	40	26	15	25	25	25
110 mph	140 mph	B	40	33	20	25	25	25
		C	40	23	14	25	25	25
		D	34	19	12	25	25	25
120 mph	150 mph	B	40	28	18	25	25	25
		C	35	20	12	25	25	25
		D	29	17	10	25	22	22

Notes:

Spacing Governed by Snow Load

- 1.) Values in above table represent the maximum allowable spacing in inches for pullout forces only on EcoFasten Solar standoff
- 2.) Maximum allowed spacing approved by EcoFasten Solar is 48"
- 3.) Maximum allowed standoff capacity = 547# (per testing results)
- 4.) Includes additional factor of safety of 1.5 for lag pullout capacity
- 5.) Values based on a maximum module length of 70"
- 6.) Based on Risk Category II (ASCE 7-10) structures less than 30 feet in height
- 7.) All adjustment factors are set to 1. No site specific engineering is included in this table

Snow Load 51-60 psf

Modules in Landscape								
Wind Speed		Exposure Category	2:12 < Roof Pitch < 6:12			7:12 < Roof Pitch < 12:12		
ASCE 7-05	ASCE 7-10		Zone 1	Zone 2	Zone 3	Zone 1	Zone 2	Zone 3
85 mph	110 mph	B	55	55	55	34	34	34
		C	55	55	42	34	34	34
		D	55	55	35	34	34	34
90 mph	115 mph	B	55	55	54	34	34	34
		C	55	55	38	34	34	34
		D	55	51	32	34	34	34
100 mph	125 mph	B	55	55	45	34	34	34
		C	55	51	32	34	34	34
		D	55	43	27	34	34	34
110 mph	140 mph	B	55	55	36	34	34	34
		C	55	41	26	34	34	34
		D	55	34	22	34	34	34
120 mph	150 mph	B	55	50	31	34	34	34
		C	55	36	22	34	34	34
		D	51	30	19	34	34	34

Notes:

Spacing Governed by Snow Load

- 1.) Values in above table represent the maximum allowable spacing in inches for pullout forces only on EcoFasten Solar standoff, however the designer must round down to meet appropriate rafter spacing
- 2.) Maximum allowed spacing approved by EcoFasten Solar is 72"
- 3.) Maximum allowed standoff capacity = 547# (per testing results)
- 4.) Includes additional factor of safety of 1.5 for lag pullout capacity
- 5.) Values based on a maximum module width of 40"
- 6.) Based on Risk Category II (ASCE 7-10) structures less than 30 feet in height
- 7.) All adjustment factors are set to 1. No site specific engineering is included in this table

Snow Load 51-60 psf

Modules in Portrait								
Wind Speed		Exposure Category	2:12 < Roof Pitch < 6:12			7:12 < Roof Pitch < 12:12		
ASCE 7-05	ASCE 7-10		Zone 1	Zone 2	Zone 3	Zone 1	Zone 2	Zone 3
85 mph	110 mph	B	33	33	33	21	21	21
		C	33	33	24	21	21	21
		D	33	32	20	21	21	21
90 mph	115 mph	B	33	33	30	21	21	21
		C	33	33	22	21	21	21
		D	33	29	18	21	21	21
100 mph	125 mph	B	33	33	26	21	21	21
		C	33	29	18	21	21	21
		D	33	26	15	21	21	21
110 mph	140 mph	B	33	33	20	21	21	21
		C	33	23	14	21	21	21
		D	33	19	12	21	21	21
120 mph	150 mph	B	33	28	18	21	21	21
		C	33	20	12	21	21	21
		D	29	17	10	21	21	21

Notes:

Spacing Governed by Snow Load

- 1.) Values in above table represent the maximum allowable spacing in inches for pullout forces only on EcoFasten Solar standoff
- 2.) Maximum allowed spacing approved by EcoFasten Solar is 48"
- 3.) Maximum allowed standoff capacity = 547# (per testing results)
- 4.) Includes additional factor of safety of 1.5 for lag pullout capacity
- 5.) Values based on a maximum module length of 70"
- 6.) Based on Risk Category II (ASCE 7-10) structures less than 30 feet in height
- 7.) All adjustment factors are set to 1. No site specific engineering is included in this table

GROUNDING INFORMATION

The rail-free Rock-It System may be used to mount and ground PV modules that comply with UL 1703, **only** when that specific module has been evaluated for mounting and grounding, in compliance with the included installation instructions.

Note: Grounding lug must be visible to inspectors from the entire perimeter of the PV array.

Multiple Use Grounding Pins

Grounding pins within the Mid-Clamp are multiple use bonding/grounding devices. Modules will need to be adjusted if the Mid-Clamps are loosened to ensure there is "new" metal to pierce into upon retightening.

Grounding Method

Rock-It 4.0 Mount bonds N-S rows of modules

Rock-It 4.0 Coupling bonds E-W rows of modules

Rock-It Array Skirt bonds E-W along the entire array when installed

One Burndy CL50-1TN ground lug is required per PV array, limited to 300 modules placed in either portrait or landscape orientation.

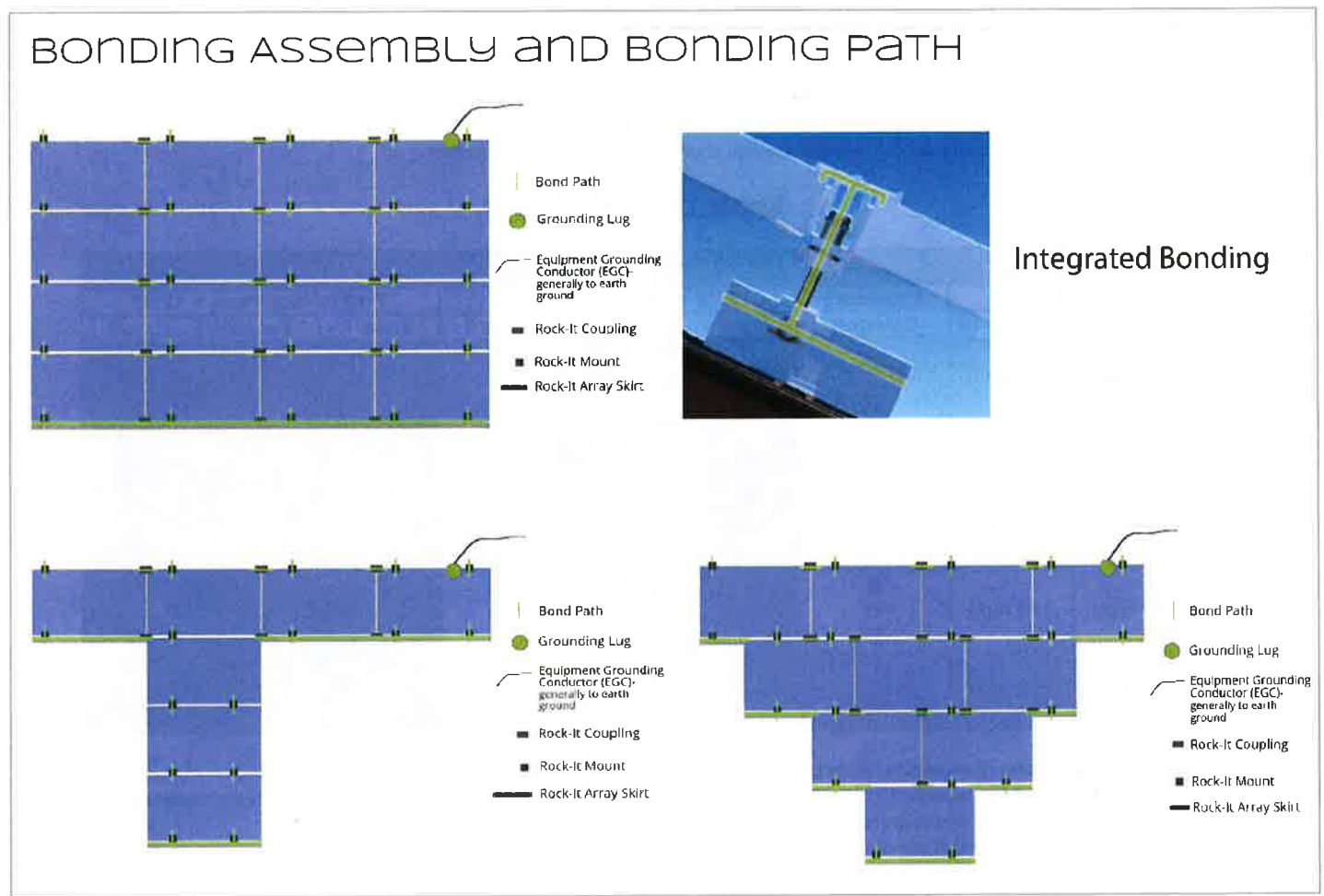

Thermal Expansion and Bonding

A thermal expansion gap is required per each continuous 40' length of modules.

Omit a coupling and leave a 2" gap in the Rock-It Array Skirt and also between the modules at that point.

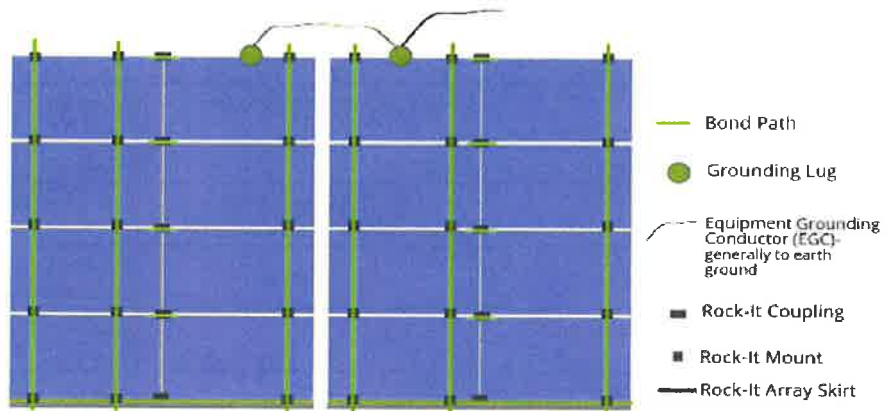

Bracket Spacing

Portrait Orientation

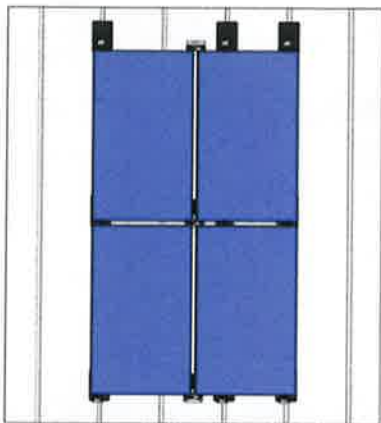

Maximum east/west bracket spacing is 48" OC.

Landscape Orientation

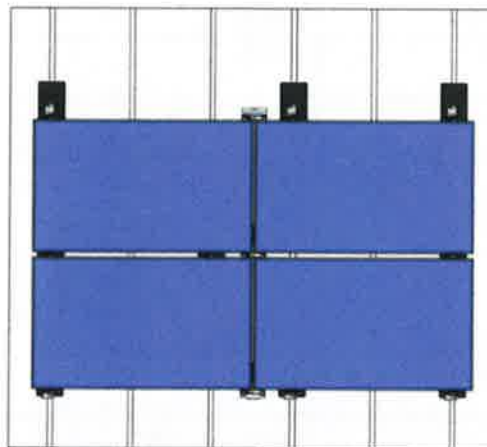

Max east/west bracket spacing is 72" OC.
32mm modules: Max east/west bracket spacing is 48" OC.

Spacing may vary depending upon project specific structural requirements; i.e. high snow and wind load areas may require lesser spacing E-W than the maximum.

Staggered Layout

Staggered Mounting Points

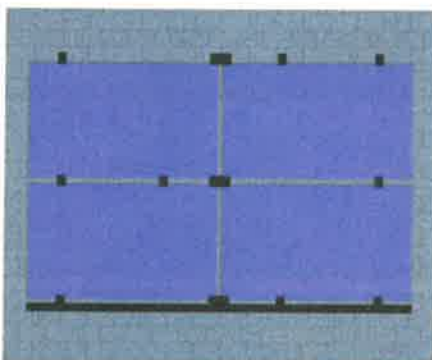

Rock-It Mount Rock-It Coupling

The array layout instructions in this installation manual offer a general overview of layout. Periodically, due to a variety of factors (roof obstacles, shading, etc.) other layouts are required.

Cantilever and Offset

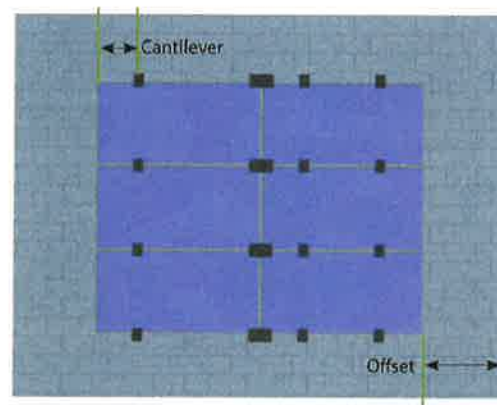

Cantilever: Maximum cantilever is 1/3 bracket spacing. For portrait orientation installations, check layout prior to installing.

Offset: Offset from all roof edges depends on wind speed, snow loads, local fire and building codes per location

ROCK-IT SYSTEM 4.0

SYSTEM SPECIFICATIONS

Max No. of Panels	300 Modules per ground lug	Materials	300 Series Stainless, 6000 Series Aluminum
Max System Voltage	1000VDC	Coating	Black Andodization/Mill Finish
Class A Fire Rating	With UL1703 Type 1 Rated Modules, see note below.	Lug Specifications	Burndy CL50-1TN Ground Lug (UL Listing #KDER E9999)
Leveling Range	3-4"	Ground Wire Per above Lug spec.	14 AWG- 4 AWG Copper Ground Wire
Rock-It Slide Comp Range Rock-It Slide Tile	3" 7"	Max Module Size	64.96"(1650mm) x 39.05"(992mm) x 2"(50mm)
Min/Max Roof Slope	1/2:12/12:12	Max Downforce/Uplift Rating	45 PSF
Max Anchor Spacing (35mm/40mm) Max Anchor Spacing (32mm)	72" 48"	Rock-It Mount Load Rating	547lbs with Single 5/16" Lag 3.0 Safety Factor
Skirt Box QTY	6 units	Slide Fastening Hole	5/16" diameter
Mount Box QTY Rock-It Slide Box QTY	12 units 50 units	Module Cantilever	Maximum cantilever is 1/3 bracket spacing
Coupling Box QTY	12 units	Warranty	20 Year Material and Workmanship

Codes: National Electric Code, ANSI/NFPA 70, NEC 250, NEC 690, IRC, IBC

Standards: UL 2703: First Edition, UL 1703



The EcoFasten Solar, Rock-It System a roof top PV racking system consisting of 6000 Series Aluminum and 300 Series Stainless steel components. The Rock-It System includes the rack components but does not include the PV panels, inverters or electrical components. The PV modules to be used with Rock-It shall be certified under UL 1703. The system shall be used on steep slope roofs mounted over a Class A fire rated roofing material and attached to the roof structure using 5/16" diameter, minimum 4" long 300 series stainless steel lag bolts with minimum thread embedment depth of 2 1/2" into the roof structure.

Periodic re-inspection for loose components

The system is subject to re-inspection as required by the PV module manufacturer or by the Authority Having Jurisdiction. Re-inspection, as required, should include evaluation of any loose components or loose fasteners. All loose components and fasteners should be secured in accordance with these instructions. The system should also be evaluated for any evidence of corrosion. Any corrosion should be removed. Any affected part should be cleaned or replace in accordance with these instructions.



FEATURES

- New and improved design
- Fastest, easiest to level system on the market
- Integrated electrical bonding
- SIMPLE- only 4 components
- North-South adjustability
- Only one tool required (1/2" deep well socket)
- Vertical adjustment of 3"-4"

EVALUATED, COMPATIBLE MODULES

Module Manufacturer	Model Type ("x" used to indicate variable test)	Module Dimensions (mm)	Module Dimensions (in)	Downward Pressure Design Load (psf)	Upward Pressure Design Load (psf)	Down-slope Design Load (psf)	Maximum Clamp Spacing (in)
Trina Solar	TSM-xxx-Px05.08	1640 x 992 x 40	64.95"x39.05"x1.57"	33.3	33.3	20	72
Canadian Solar	CS6P-xxxM	1638 x 922 x 40	64.48"x38.66"x1.57"	33.3	33.3	20	72
Canadian Solar	CS6P-xxxP	1638 x 982 x 40	64.5"x38.7"x1.57"	33.3	33.3	20	72
Jinko Solar	JKMxxxP-60	1650 x 992 x 40	64.96"x39.05"x1.57"	30	30	20	72
Jinko Solar	JKMxxxM-60	1650 x 992 x 40	64.96"x39.05"x1.57"	30	30	20	72
Jinko Solar	JKMxxxPP-60	1650 x 992 x 40	64.96"x39.05"x1.57"	30	30	20	72
Jinko Solar	JKMxxxMM-60	1650 x 992 x 40	64.96"x39.05"x1.57"	30	30	20	72
Yingli Solar	YL2xxP-29b	1650 x 990 x 40	64.96"x38.97"x1.57"	30	30	20	72
LG Elctronics	LG300N1 C-B3	1640 x 1000 x 35	64.57"x39.37"x1.38"	30	30	20	72
LG Elctronics	LG300N1K-G4	1640 x 1000 x 40	64.57"x39.37"x1.57"	30	30	20	72
Axitec Solar	AC-xxxM/156-60S	1640 x 992 x 40	64.5"x39.06"x1.38"	30	30	20	48
RECOM	RCM-2xx-6MB	1640 x 992 x 35	64.56"x39.05"x1.37"	30	30	20	72
Silfab	SLA2xxP	1650 x 990 x 38	64.96"x38.97"x1.49"	30	30	20	72
Solaria	PowerXT xxxR-BX	1621 x 1056 x 40	63.89"x41.53"x1.57"	30	30	20	48
Hanwha - Q Cells*	Q.PRO G4 2xx	1670 x 1000 x 32	65.75"x39.37"x1.25"	30	30	20	48
Hanwha - Q Cells*	Q.PRO G4 2xx	1670 x 1000 x 32	65.75"x39.37"x1.25"	30	30	20	72
Sunpreme	GxB-3xx T	1670 x 997 x 40	65.75"x39.25"x1.57"	30	30	20	48
REC	REC-xxx-6MB	1675 x 997 x 38	65.94"x39.25"x1.5"	20	20	20	72
REC	REC-xxx-6MB	1675 x 997 x 38	65.94"x39.25"x1.5"	30	30	20	48
SolarWorld	SW xxx Mono Black	1675 x 961 x 33	65.95"x37.8"x1.30"	20	20	20	72
SolarWorld	SW xxx Mono Black	1675 x 961 x 33	65.95"x37.8"x1.30"	30	30	20	48

Hanwha Q- Cells 32mm modules to be used with special order Rock-It System components. Call for details.



Single Phase Inverter with HD-Wave Technology

for North America

SE3000H-US / SE3800H-US / SE5000H-US / SE6000H-US /
SE7600H-US / SE10000H-US / SE11400H-US



Optimized installation with HD-Wave technology

- / Specifically designed to work with power optimizers
- / Record-breaking efficiency
- / Fixed voltage inverter for longer strings
- / Integrated arc fault protection and rapid shutdown for NEC 2014 and 2017, per article 690.11 and 690.12
- / UL1741 SA certified, for CPUC Rule 21 grid compliance
- / Extremely small
- / Built-in module-level monitoring
- / Outdoor and indoor installation
- / Optional: Revenue grade data, ANSI C12.20 Class 0.5 (0.5% accuracy)

/ Single Phase Inverter

with HD-Wave Technology for North America

SE3000H-US / SE3800H-US / SE5000H-US / SE6000H-US/
SE7600H-US / SE10000H-US / SE11400H-US

SE3000H-US SE3800H-US SE5000H-US SE6000H-US SE7600H-US SE10000H-US SE11400H-US

OUTPUT

Rated AC Power Output	3000	3800 @ 240V 3300 @ 208V	5000	6000 @ 240V 5000 @ 208V	7600	10000	11400 @ 240V 10000 @ 208V	VA
Maximum AC Power Output	3000	3800 @ 240V 3300 @ 208V	5000	6000 @ 240V 5000 @ 208V	7600	10000	11400 @ 240V 10000 @ 208V	VA
AC Output Voltage Min.-Nom.-Max. (211 - 240 - 264)	✓	✓	✓	✓	✓	✓	✓	Vac
AC Output Voltage Min.-Nom.-Max. (183 - 208 - 229)	-	✓	-	✓	-	-	✓	Vac
AC Frequency (Nominal)	59.3 - 60 - 60.5 ¹⁾							Hz
Maximum Continuous Output Current @240V	12.5	16	21	25	32	42	47.5	A
Maximum Continuous Output Current @208V	-	16	-	24	-	-	48.5	A
GFDI Threshold	1							A
Utility Monitoring, Islanding Protection, Country Configurable Thresholds	Yes							

INPUT

Maximum DC Power @240V	4650	5900	7750	9300	11800	15500	17650	W
Maximum DC Power @208V	-	5100	-	7750	-	-	15500	W
Transformer-less, Ungrounded	Yes							
Maximum Input Voltage	480							Vdc
Nominal DC Input Voltage	380			400				Vdc
Maximum Input Current @240V ²⁾	8.5	10.5	13.5	16.5	20	27	30.5	Adc
Maximum Input Current @208V ²⁾	-	9	-	13.5	-	-	27	Adc
Max. input Short Circuit Current	45							Adc
Reverse-Polarity Protection	Yes							
Ground-Fault Isolation Detection	600k Ω Sensitivity							
Maximum Inverter Efficiency	99	99.2						%
CEC Weighted Efficiency	99						99 @ 240V 98.5 @ 208V	%
Nighttime Power Consumption	< 2.5							W

ADDITIONAL FEATURES

Supported Communication Interfaces	RS485, Ethernet, ZigBee (optional), Cellular (optional)
Revenue Grade Data, ANSI C12.20	Optional ³⁾
Rapid Shutdown - NEC 2014 and 2017 690.12	Automatic Rapid Shutdown upon AC Grid Disconnect

STANDARD COMPLIANCE

Safety	UL1741, UL1741 SA, UL1699B, CSA C22.2, Canadian AFCI according to T.I.L. M-07
Grid Connection Standards	IEEE1547, Rule 21, Rule 14 (HI)
Emissions	FCC Part 15 Class B

INSTALLATION SPECIFICATIONS

AC Output Conduit Size / AWG Range	1" Maximum / 14-6 AWG		1" Maximum / 14-4 AWG	
DC Input Conduit Size / # of Strings / AWG Range	1" Maximum / 1-2 strings / 14-6 AWG		1" Maximum / 1-3 strings / 14-6 AWG	
Dimensions with Safety Switch (HxWxD)	17.7 x 14.6 x 6.8 / 450 x 370 x 174		21.3 x 14.6 x 7.3 / 540 x 370 x 185	
Weight with Safety Switch	22 / 10	25.1 / 11.4	26.2 / 11.9	38.8 / 17.6
Noise	< 25		*50	
Cooling	Natural Convection			
Operating Temperature Range	-13 to +140 / -25 to +60 ⁴⁾ (-40°F / -40°C option) ⁵⁾			
Protection Rating	NEMA 4X (Inverter with Safety Switch)			

¹⁾ For other regional settings please contact SolarEdge support

²⁾ A higher current source may be used, the inverter will limit its input current to the values stated

³⁾ Revenue grade inverter P/N: SExxxxH-US000NNC2

⁴⁾ For power derating information refer to: <https://www.solaredge.com/sites/default/files/se-temperature-derating-note-na.pdf>

⁵⁾ -40 version P/N: SExxxxH-US000NNU4

Power Optimizer

For North America

P320 / P340 / P370 / P400 / P405 / P505



POWER OPTIMIZER

PV power optimization at the module-level

- Specifically designed to work with SolarEdge inverters
- Up to 25% more energy
- Superior efficiency (99.5%)
- Mitigates all types of module mismatch losses, from manufacturing tolerance to partial shading
- Flexible system design for maximum space utilization
- Fast installation with a single bolt
- Next generation maintenance with module-level monitoring
- Meets NEC requirements for arc fault protection (AFCI) and Photovoltaic Rapid Shutdown System (PVRSS)
- Module-level voltage shutdown for installer and firefighter safety

/ Power Optimizer

For North America

P320 / P340 / P370 / P400 / P405 / P505

Optimizer model (typical module compatibility)	P320 (for 60-cell modules)	P340 (for high-power 60-cell modules)	P370 (for higher-power 60 and 72-cell modules)	P400 (for 72 & 96-cell modules)	P405 (for thin film modules)	P505 (for higher current modules)		
INPUT								
Rated Input DC Power ⁽¹⁾	320	340	370	400	405	505	W	
Absolute Maximum Input Voltage (Voc at lowest temperature)	48		60	80	125 ⁽²⁾	87 ⁽²⁾	Vdc	
MPPT Operating Range	8 - 48		8 - 60	8 - 80	12.5 - 105	12.5 - 87	Vdc	
Maximum Short Circuit Current (Isc)	11			10.1		14	Adc	
Maximum DC Input Current	13.75			12.5		17.5	Adc	
Maximum Efficiency	99.5							%
Weighted Efficiency	98.8					98.6		%
Overvoltage Category	II							
OUTPUT DURING OPERATION (POWER OPTIMIZER CONNECTED TO OPERATING SOLAREEDGE INVERTER)								
Maximum Output Current	15						Adc	
Maximum Output Voltage	60			85			Vdc	
OUTPUT DURING STANDBY (POWER OPTIMIZER DISCONNECTED FROM SOLAREEDGE INVERTER OR SOLAREEDGE INVERTER OFF)								
Safety Output Voltage per Power Optimizer	1 ± 0.1						Vdc	
STANDARD COMPLIANCE								
EMC	FCC Part15 Class B, IEC61000-6-2, IEC61000-6-3							
Safety	IEC62109-1 (class II safety), UL1741							
Material	UL94 V-0, UV Resistant							
RoHS	Yes							
INSTALLATION SPECIFICATIONS								
Maximum Allowed System Voltage	1000						Vdc	
Compatible inverters	All SolarEdge Single Phase and Three Phase inverters							
Dimensions (W x L x H)	129 x 153 x 27.5 / 5.1 x 6 x 1.1			129 x 153 x 33.5 / 5.1 x 6 x 1.3	129 x 159 x 49.5 / 5.1 x 6.3 x 1.9	129 x 162 x 59 / 5.1 x 6.4 x 2.3	mm / in	
Weight (including cables)	630 / 1.4			750 / 1.7	845 / 1.9	1064 / 2.3	gr / lb	
Input Connector	MC4 ⁽³⁾				Single or dual MC4 ^(3,4)	MC4 ⁽³⁾		
Input Wire Length	0.16 / 0.52						m / ft	
Output Wire Type / Connector	Double Insulated / MC4							
Output Wire Length	0.9 / 2.95			1.2 / 3.9			m / ft	
Operating Temperature Range ⁽⁵⁾	-40 - +85 / -40 - +185							°C / °F
Protection Rating	IP68 / NEMA6P							
Relative Humidity	0 - 100						%	

⁽¹⁾ Rated power of the module at STC will not exceed the optimizer "Rated Input DC Power". Modules with up to +5% power tolerance are allowed.

⁽²⁾ NEC 2017 requires max input voltage be not more than 80V

⁽³⁾ For other connector types please contact SolarEdge

⁽⁴⁾ For dual version for parallel connection of two modules use the P405. In the case of an odd number of PV modules in one string, installing one P405 dual version power optimizer

⁽⁵⁾ For ambient temperature above +85°C / +185°F power de-rating is applied. Refer to Power Optimizers Temperature De-Rating Technical Note for more details.

PV System Design Using a SolarEdge Inverter ⁽⁶⁾⁽⁷⁾	Single Phase HD-Wave	Single phase	Three Phase 208V	Three Phase 480V	
Minimum String Length (Power Optimizers)	P320, P340, P370, P400 P405 / P505	8	10	18	
Maximum String Length (Power Optimizers)		25	25	50 ⁽⁸⁾	
Maximum Power per String	5700 (6000 with SE7600-US - SE11400-US)	5250	6000 ⁽⁹⁾	12750 ⁽⁹⁾	W
Parallel Strings of Different Lengths or Orientations	Yes				

⁽⁶⁾ For detailed string sizing information refer to: http://www.solaredge.com/sites/default/files/string_sizing_na.pdf

⁽⁷⁾ It is not allowed to mix P405/P505 with P320/P340/P370/P400 in one string.

⁽⁸⁾ A string with more than 30 optimizers does not meet NEC rapid shutdown requirements; safety voltage will be above the 30V requirement

⁽⁹⁾ For SE14.4KUS/SE43.2KUS: It is allowed to install up to 6,500W per string when 3 strings are connected to the inverter (3 strings per unit for SE43.2KUS) and when the maximum power difference between the strings is up to 1,000W

⁽¹⁰⁾ For SE30KUS/SE33.3KUS/SE66.6KUS/SE100KUS: It is allowed to install up to 15,000W per string when 3 strings are connected to the inverter (3 strings per unit for SE66.6KUS/SE100KUS) and when the maximum power difference between the strings is up to 2,000W