

Installation Manual

QSJ2.4 Engine with PowerCommand® 1.1 Control

C20 N6 (Spec A), C22 N6 (Spec A)

C25 N6 (Spec A), C30 N6 (Spec A)

C36 N6 (Spec A), C40 N6 (Spec A)

C30 N6H (Spec A), C36 N6H (Spec A)

C40 N6H (Spec A), C45 N6H (Spec A)

C50 N6H (Spec A), C60 N6H (Spec A)

4 Installation

NOTICE

The installer is responsible for complying with all applicable installation codes and safety requirements. See the Installation Codes and Standards for Safety section of this manual for more information.

The following sections cover a step-by-step overview of a typical generator set installation.

Review these sections to become familiar with specific procedures and important safety precautions before beginning the installation.

4.1 Site Assessment and Preparation

Proper component location and site preparation have a very important impact on completing a successful installation. The major components and sources of power needed for installation include the following items:

- Generator set
- Transfer switch
- Electrical utility
- Fuel source: natural gas or propane vapor
- Accessories (may be required under certain conditions)

Picking a Location

⚠ WARNING

Exhaust gas is deadly. Locate the generator set away from doors, windows, and other openings to the house and where exhaust gases will disperse away from the house.

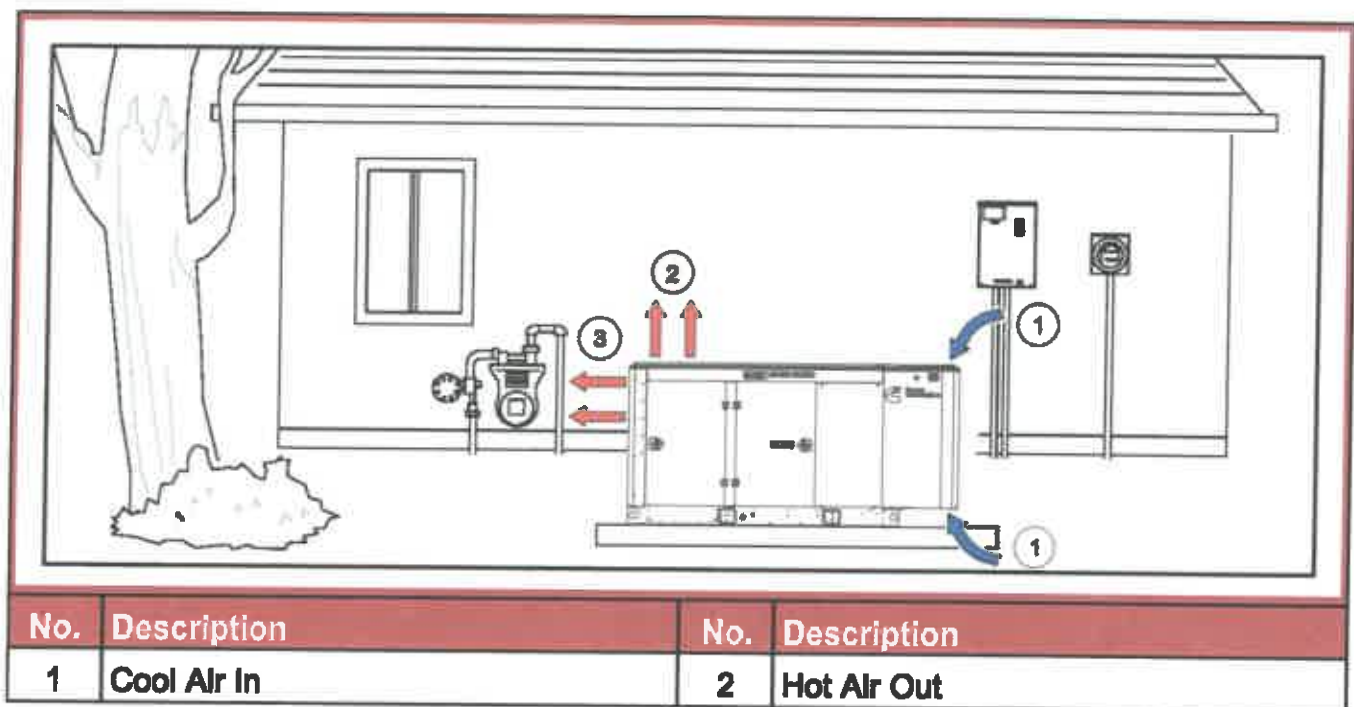

FIGURE 3. GENERATOR SET LOCATION

Generator set location is critical for safety and performance. Follow the guidelines below:

- Must comply with applicable codes (NFPA, NEC, IBC, etc.).
- Install outdoors only. For other applications, contact your local Cummins dealer or reference the Application Manual at the following link: <http://www.cumminspower.com/www/literature/applicationmanuals/t030.pdf>
- Consider access to utilities (electric/gas meters, transfer switch, remote fuel tank location, etc.).
- Call the local utilities to mark the locations of buried utility services (gas, electric, or telephone) before digging.
- Verify the locations of any other buried components (gas, electric or telephone) with the homeowner before digging.

Clearances:

- The exhaust side of the generator set must be located 5 feet from combustible materials (NFPA 37).
- The exhaust side of the generator must be located 5 feet from any opening in a wall (window, door, vent, etc.).
- The generator must be located such that the exhaust is not able to accumulate in an occupied area.
- The generator must have enough room for installation, service, and maintenance.
- The generator must be located to ensure ventilation openings are not blocked.

- Position the generator set so that cooling air is free to enter and leave the area.
- Locate and position the generator set so that prevailing winds carry exhaust gases and potential fuel leaks away from the house or occupied area.

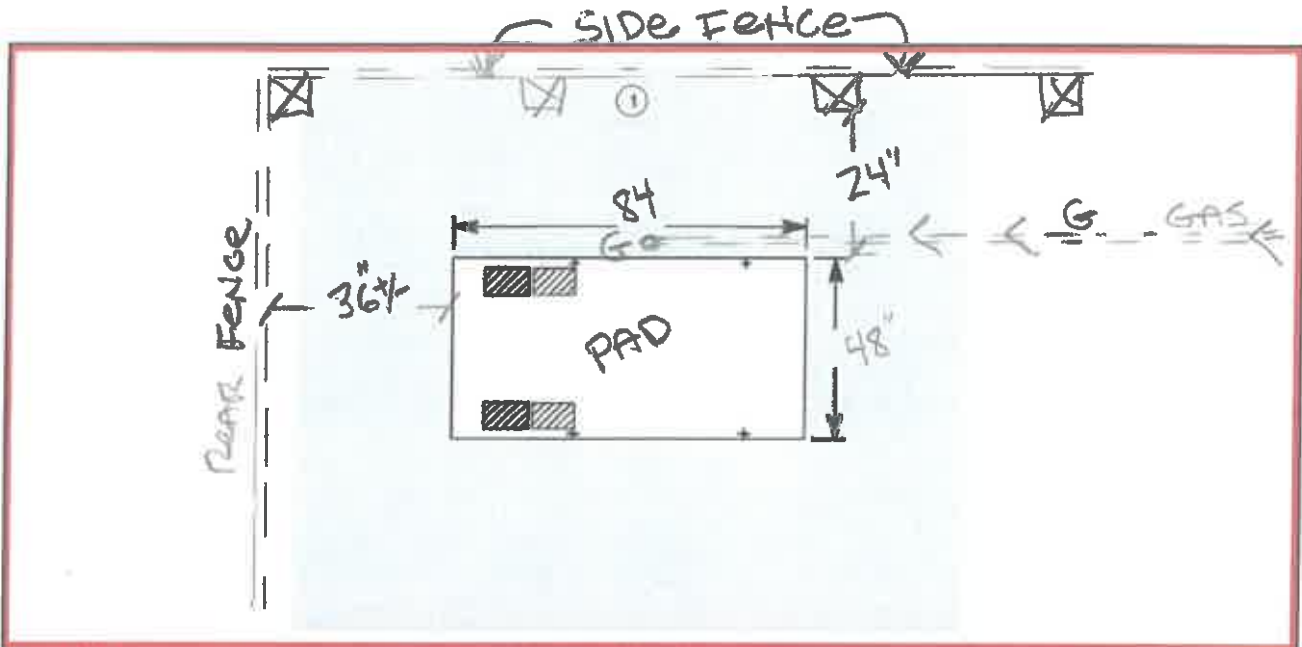

No.	Description
1	5 ft Clearance (Shaded Area)

FIGURE 4. CLEARANCES

Laying the Foundation

When laying the foundation:

1. Clear obstructions, and make sure that there is adequate clearance for access.
2. Level the ground, and make sure that the ground is compact and settled. Ensure that it is stable ground, not subject to flooding.
3. Prepare the concrete pad.
 - The pad should be constructed of reinforced concrete with a 28-day compressive strength of at least 2500 psi (17,237 kPa).
 - The pad should be at least 5 inches (127 mm) deep and extend at least 6 inches (150 mm) beyond the skid on all sides.

NOTICE

Seismic installation may require a different pad and securing devices.

NOTICE

Local codes and standards may have different requirements.

4. Lift the generator set onto the pad, and secure it.

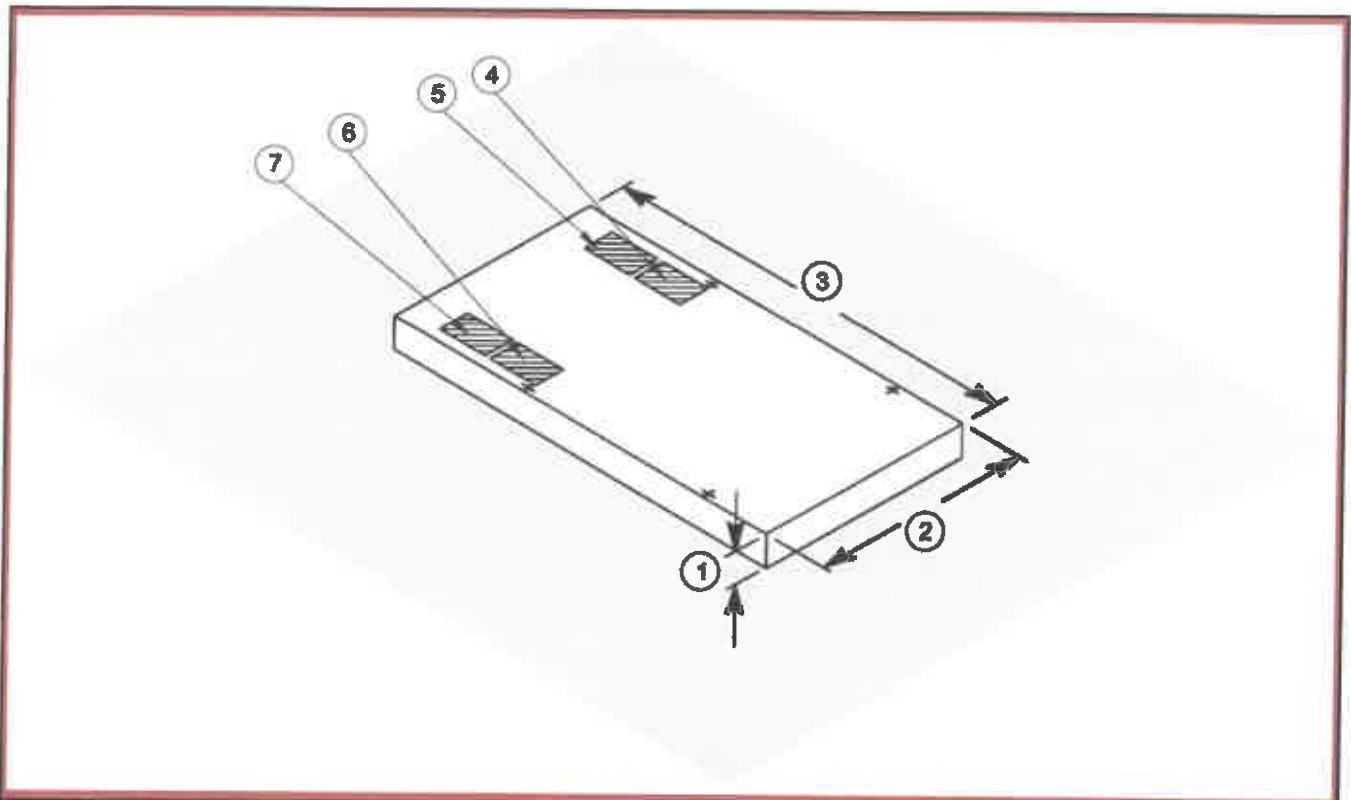

No.	Description	No.	Description
1	Pad Thickness (Minimum 5 in)	5	Accessory 120 VAC, 20A Max Wire Stub-Up
2	Pad Width (Must Extend Minimum 6 in Beyond Skid)	6	Circuit Breaker 2 Stub-Up (Dual Circuit Breaker)
3	Pad Length (Must Extend Minimum 6 in Beyond Skid)	7	Circuit Breaker 1 Stub-Up (Standard)
4	Generator Set Control Wire Stub-Up (DC)		

FIGURE 5. CONCRETE PAD PREPARATION

Lifting and Moving the Generator Set

⚠ WARNING

Heavy Load

The generator set is heavy. Handle with care.

Use appropriate lifting techniques to move the generator set. Do not use the lifting eyes on the engine and alternator to lift the entire generator set.

Dropping the generator set can cause severe personal injury or death. Keep feet and hands clear when lifting the generator set.

⚠ CAUTION

The generator set is shipped with oil in the engine crankcase. Keep the generator set upright.

Mounting the Generator Set

Positioning of cast-in bolts can be problematic since even small errors in location can cause time consuming re-drilling of the skid base. Some generator set designs allow use of concrete anchor bolts.

Mount the generator set on a substantial and level base such as a concrete pad. A non-combustible material must be used for the pad. Verify that the mounting pad is level lengthwise, widthwise, and diagonally.

NOTICE

Seismic installation may require specific anchorage.

4.2 Fuel Selection and Fuel System Connection

For fuel specifications (such as BTU/hr), see the [Model Specifications](#) section.

NOTICE

This generator set has a convertible fuel system. The generator may run on natural gas or propane, depending on the preferences of the owner. All generator sets come preconfigured from the factory for natural gas fuel. For more information on converting the fuel system type, reference the Service Manual (A045R243).

NOTICE

Fuel systems must be installed by qualified service technicians. Improper installation presents hazards of fire and improper operation, resulting in severe personal injury or property damage.

⚠ WARNING

Gaseous fuels are flammable, explosive, and can cause severe personal injury or death. Do not smoke if you smell gas, are near fuel tanks for fuel-burning equipment, or are in an area sharing ventilation with such equipment. Keep flames, sparks, pilot lights, electrical arcs, arc-producing equipment and all other sources of ignition well away. Keep a type ABC fire extinguisher handy.

In all fuel system installations, cleanliness is extremely important.

- Make every effort to prevent fuel contamination from:
 - Moisture
 - Dirt
 - Excess thread sealant
 - Contaminants of any kind
- Clean all fuel system components before installing.

Gaseous-fuel supply system design, materials, components, fabrication, assembly, installation, testing, inspection, operation, and maintenance must comply with the applicable codes. See NFPA Standards No. 37, 54, and 58. For seismic installation, refer to IBC codes and standards. Where seismic installation is required, there may be specific anchorage requirements for the generator set and other installed components.

Most codes require a manual shutoff valve ahead of a flexible fuel hose. The manual valve should be of the indicating type. The generator set has electric (battery-powered) shutoff valves included.

NOTICE

It is recommended that a shutoff valve be located near the generator set for emergency shut off or servicing the generator set. Follow applicable codes.

Until the generator set is connected, cap the fuel line stub-up at the generator set to prevent dirt from entering and gas from discharging if the gas supply shutoff valve is opened accidentally.

To determine the required capacity, add generator set consumption to the gas consumed for heating, cooking, clothes drying, etc. A typical natural gas installation might require a 400,000 BTU meter. Consideration should also be given to utilizing high pressure gas supply if available. This reduces the required size and cost of gas piping, especially if the location of the generator set requires a long supply line.

Natural Gas Fuel System

Requirements for a natural gas generator set are as follows:

TABLE 15. NATURAL GAS GENERATOR SET REQUIREMENTS

Component	Description
Gas	Pipeline quality
Fuel Supply	Adequate fuel supply to operate correctly and run at full load
Shutoff Valve	Manual

Component	Description
Fuel Pipe Size	The length of the fuel supply pipe from the gas service entrance to the generator set must be known to determine the correct fuel pipe size. Refer to the charts in the Fuel Line Selection appendix. Iron pipe must be a minimum of schedule 40 subject to the authority having jurisdiction.
Flexible Fuel Line	Protects the fuel system from vibration, expansion, and contraction.

⚠ WARNING

Fuel leaks can lead to explosive accumulations of gas. Prevent gas leaks and the accumulation of gaseous fuel in the event of a leak.

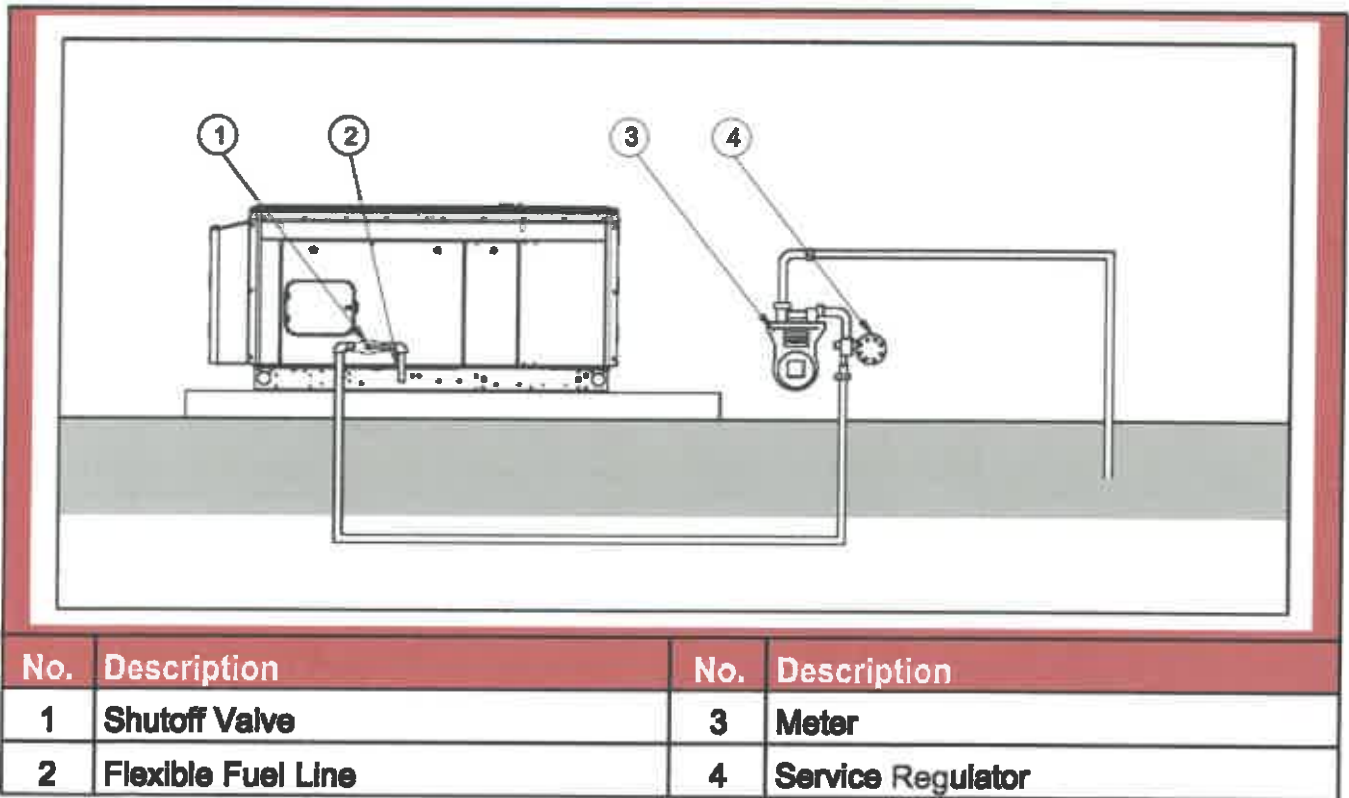

FIGURE 6. TYPICAL NATURAL GAS INSTALLATION

Natural Gas Supply Line Size

The natural gas supply meter may need to be exchanged for a higher capacity meter to supply the additional gas consumed by the generator set.

Use the total load requirement of the generator set to determine the size of the fuel supply pipe. Use the tables and charts in the [Fuel Line Selection](#) appendix to determine the correct pipe size.

An older site might require upgrading and repair of the gas supply system. Schedule an upgrade or repair to minimize power and gas supply interruptions.

Make sure the full load fuel supply pressure at the Inlet to the generator fuel shutoff valves is set at 6 - 12 inch water column (1.5 - 3.0 kPa) for all operating loads (no load to full load). (The maximum pressure under any condition is 13 inch water column [3.2 kPa].) Refer to the Model Specifications section.

Propane Fuel System

Propane vapor can be used as a primary fuel source or as a backup fuel source for the generator sets with two independent fuel sources connected to the generator set.

⚠ WARNING

Fuel leaks can lead to explosive accumulations of gas. Propane sinks in air and can accumulate inside housings, basements, and other below-grade spaces. Prevent gas leaks and the accumulation of gaseous fuel in the event of a leak.

NOTICE

NFPA Standard No. 58 requires all persons handling and operating propane to be trained in proper handling and operating procedures.

The required components in a propane vapor fuel system are as follows:

Component	Description
Propane Tank	Make sure to identify and utilize the correct tank size based on fuel flow requirements and the lowest average temperature for your region. If the tank is sized incorrectly, the generator set could run out of fuel. Refer to the Minimum LPG Tank Size figure in the Fuel Line Selection appendix.
Shutoff Valve	Useful during installation or in the event of a leak (may be required to meet local codes).
Primary Regulator	Located at the tank outlet, the primary regulator reduces the tank pressure to the working pressure in the fuel supply line. Primary and secondary regulators must be properly matched for a safe and functional system. Consult with your propane supplier to ensure that the regulators are properly sized.

Component	Description
Secondary Regulator	Located near the generator set, the secondary regulator reduces the higher line pressure to a working pressure of 6 - 12 Inch water column (1.5 - 3.0 kPa). Higher pressure before the secondary regulator is necessary to ensure that there is enough fuel available at the secondary regulator for a fully loaded generator set.
Fuel Line	Connects to the fuel supply. It must be sized properly using the propane fuel line sizing charts (see the Fuel Line Selection appendix). Installation must comply with all national, state, and local codes.
Cummins Flexible Fuel Line	Protects the fuel system from vibration, expansion, and contraction.

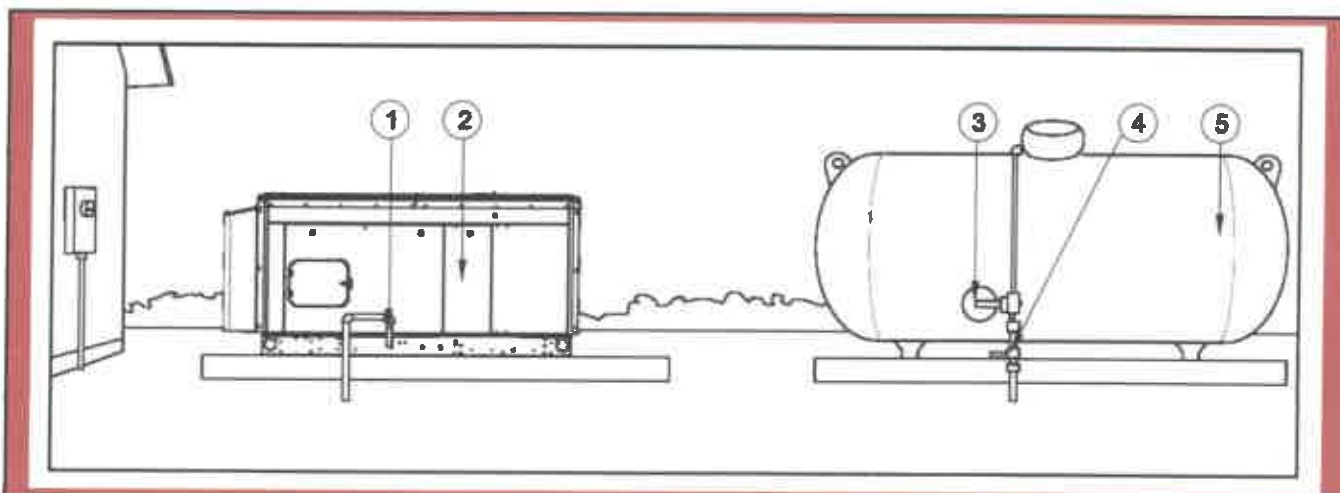

No.	Description	No.	Description
1	Flexible Fuel Line	4	Shutoff Valve
2	Generator Set	5	Propane Tank
3	Service Regulator		

FIGURE 7. TYPICAL PROPANE INSTALLATION

Propane Fuel

⚠ WARNING

Propane presents the hazard of fire or explosion that can cause severe personal injury or death. Do not permit any flame, spark, arc-producing equipment, switch, pilot light, cigarette, or other ignition source near the fuel system. Keep an ABC type fire extinguisher nearby.

⚠ WARNING

Fuel leaks can lead to explosive accumulations of gas. Propane sinks in air and can accumulate inside housings, basements and other below-grade spaces. Prevent gas leaks and the accumulation of gaseous fuel in the event of a leak.

Use clean, fresh HD-5 grade propane or equivalent product consisting of at least 90% propane.

NOTICE

NFPA Standard No. 58 requires all persons handling and operating propane to be trained in proper handling and operating procedures.

NOTICE

Commercial propane may contain more than 2.5% butane, which can result in poor fuel vaporization and low tank pressure, resulting in poor engine starting and operation in below 32 °F (0 °C) temperatures.

Propane Tank Size

When propane is used, size the tank correctly to ensure successful generator set operation.

Considerations when figuring the proper propane tank size:

- Temperature is a critical factor that affects the size of the tank.
 - Ambient temperatures can affect how quickly liquid is converted to gas.
 - Generator set fuel consumption is the same regardless of the surrounding temperatures.
 - Colder weather climates require larger fuel tanks. Larger tanks have greater surface area, allowing more liquid propane to vaporize and maintain the required fuel rate.
 - Propane is stored as liquid. Keep the fuel tank at least 50% full to operate properly. Fuel tanks that are less than 50% full may not have the capacity to vaporize enough propane to operate the generator set and other LP appliances.
- Propane tanks are sized by their internal volume in gallons, not the amount of fuel they can hold (which is less).
- Propane tanks are generally filled to only 80% of their capacity. Therefore, a 500-gallon (1892-liter) tank results in 400-gallon (1514-liter) tank capacity.
- Low ambient temperatures affect the amount of fuel available from the propane tank.

- Approximately 60% of the fuel (in gallons) filled in the tank can be effectively used. Therefore, a 500-gallon (1892-liter) tank results in 240-gallon (908-liter) usable capacity.

To assist in the proper installation of the propane tank, follow the guidelines below.

- Consult your tank and propane supplier for assistance in all aspects of determining tank size, selection of components and installation requirements.
- Fit the propane tanks with a pressure reducing regulator before connection to the generator set to prevent fuel system damage.
- Locate the propane tanks and all other fuel system components at least 10 feet (3 meters) from any source of combustion (including the generator set). The fuel supplier or local code may require a larger distance between the tank and source of combustion.
- Install the propane tanks according to all national and local codes and standards, and as required by the fuel tank and fuel supplier.

Refer to the [Fuel Line Selection](#) appendix for propane figures and tables.

Sizing Fuel Lines

Incorrect fuel line size may cause the generator set to not run or provide full power output. Fuel line sizes for installations typically range from 1/4 to 2 or more inches in diameter.

To determine the optimal fuel line size, the following information is needed:

Category	Description
Fuel Flow Requirements for the Generator Set	Fuel flow requirements have a large impact on fuel line size.
Fuel Source (Natural Gas or Propane Vapor)	Fuel sources can affect fuel line size. Natural gas installations generally require a higher fuel flow rate compared to propane vapor installations, since propane has a higher energy content.
Fuel Line Length (Including Fittings)	Factor in the equivalent lengths of all of the fittings (elbows, tees, valves) in the installation in addition to the fuel line length. Longer lengths require larger diameters.
Fuel Line Type (e.g., Copper Tubing or Iron Pipe)	Most fuel line types are iron pipe or copper tubing. Be sure to use the sizing chart for the fuel line type when sizing the fuel line.

There are some basic but very important steps all installers must follow to make sure that fuel lines are sized correctly:

1. Verify adequate fuel flow, quality, and pressure available from utility connection.

2. Determine fuel requirements at full load. See the Model Specifications section to determine the fuel flow requirements.
3. Determine equivalent length of fuel line fittings required. See the NFPA Pipe Fittings table in the [Fuel Line Selection](#) appendix to determine the equivalent lengths for elbows, tees, and valves. Add this length to fuel line length to determine total equivalent length.
4. Determine required fuel line size at full load. See the [Fuel Line Selection](#) appendix to determine the fuel line size.

To calculate the minimum pipe size:

1. Make a list of all the fittings and valves in a proposed system and add their equivalent lengths.
2. Add all lengths of straight pipe to arrive at a total equivalent length to the fittings/valves total.
3. Choose the applicable table based on the fuel system and fuel line material.
4. Obtain the maximum fuel requirements for the specific generator set from the Model Specifications section.
5. Refer to the fuel line sizing charts in the [Fuel Line Selection](#) appendix. Locate the equivalent length of pipe (or next larger equivalent length) in the left hand column. Move across the row to where the maximum capacity number is as large or larger than the maximum fuel consumption (or next larger). At the top of that column is the minimum nominal pipe size or tubing size required for the system as designed.

Installing Fuel Lines

The basic components required for fuel line installation are as follows:

- Flexible connection
- Fuel line
- Shutoff valve
- Fuel supply

To install the fuel lines:

1. Connect a flexible fuel line to the fuel connection ports on the generator set.
2. Connect the opposite end of the flexible fuel line to the fuel source line near the shutoff valve.

NOTICE

A shutoff valve is recommended and often required by local and state codes.

Testing the Fuel System for Leaks

After assembly and before initial operation, all of the fuel system components must be tested and proven free of any leaks.