



**1016 Clegg Court
Petaluma, CA 94954
ACO28–Contractor License # 880138
(707) 769-3519 Fax: (707) 776-2919**



I. PROTECTED PREMISE

**Trione Winery
19550 Geyserville Ave
Geyserville, Ca. 95441**

II. MONITORING COMPANY

**Bay Alarm Company
5130 Commercial Circle
Concord, CA 94520
800-470-1000**

**California Alarm Operating License
Number: ACO28**

**Central Station Listing # 223646-006, File # S576-1
(UUFX) Protective Signaling Services – Central Station**

III. EQUIPMENT SUPPLIER & INSTALLER

**Bay Alarm Company
1016 Clegg Court
Petaluma, CA 94954**

**California Contractors License
Number: 880138 C-10**



Date: 03/03/22

Subject: Fire Alarm Communication Change

REVISION 1 SCOPE OF WORK

This is an existing facility with an existing fire alarm system installed by others. The existing fire alarm system consists of a fire sprinkler monitoring, elevator safety functions, manual fire alarm boxes, smoke detection, fire pump supervision, and audible/visual notification appliances.

The scope of work is to change the communication pathway to the central station from analog phone lines to GSM cellular communication. The dedicated 120VAC circuit that powers the FACU shall power the new cellular communicator. The new cellular communicator shall have its own standby battery. The new communicator is compatible with the existing fire alarm control unit. The new cellular communicator shall be installed as per the requirements NFPA72, 2016 edition, 26.6.3.3 & 26.6.3.5.

No other changes or work will be done do the system.



Below is the zone list with descriptions that are transmitted to the central station.

<u>Zone</u>	<u>Description</u>
02	Manual fire alarm boxes at the upper front and lower back doors
03	Butterfly tamper at the Stone Building riser
05	Waterflow at the north corner of Stone Building
06	Smoke detector at the server room
22	Manual fire alarm boxes throughout
26	Smoke detectors at upstairs hall and elevator lobby
30	Fire trouble
33	1-PIV & 6-Butterfly tampers throughout
55	Waterflow at pump room
66	3-Smoke detectors throughout
501	Elevator shunt trip trouble
506	Smoke detector at elevator machine room
521	Heat detector at elevator machine room



Also attached are the specification sheets, installation manual and CSFM listing of the new cellular communicator as well as standby battery calculations for the cellular communicator.

Thank you for your attention to this matter.

Best regards,

A handwritten signature in black ink, appearing to read 'Dom Fontana'.

Dominic Fontana CET

**Field System Designer
Bay Alarm Company
Direct: (707) 769-3519, Email: dominic.fontana@bayalarm.com**

STANDBY BATTERY CALCULATIONS

QTY	MODEL NO.	DESCRIPTION	STANDBY		ALARM	
			EACH	TOTAL	EACH	TOTAL
1	HWF2V-COM	HONEYWELL IP INTERNET & LTE CELLULAR FIRE ALARM COMMUNICATOR, VERIZON NETWORK	0.2300	0.2300	0.9500	0.9500
		PANEL STANDBY CURRENT		0.2300		
		PANEL ALARM CURRENT				0.9500
FIELD DEVICES						
QTY	MODEL NO.	DESCRIPTION	EACH	TOTAL	EACH	TOTAL
		DEVICE STANDBY CURRENT		0.0000		0.0000
		DEVICE ALARM CURRENT				0.0000
TOTAL SYSTEM CURRENT						
		DESCRIPTION		STANDBY		ALARM
		CONTROL PANEL		0.2300		0.9500
		FIELD DEVICES		0.0000		0.0000
		TOTAL STANDBY CURRENT		0.2300		0.0000
		X 24 HOUR STANDBY		5.5200		
		TOTAL ALARM CURRENT				0.9500
		15 MINUTES OF ALARM (X .25)				0.2375
		TOTAL REQUIRED CAPACITY (Amp-Hours)				5.7575
		SAFETY FACTOR				0%
		REQUIRED BATTERY CAPACITY (Amp-Hours)				6.9090
		BATTERY SUPPLIED (Amp-Hours)				7.00 Ah
		EXCESS BATTERY CAPACITY SUPPLIED (Amp-Hours)				0.0910

HWF2-COM SERIES

LTE / IP Single or Dual Path Commercial Fire Communicators

The HWF2-COM Series LTE / IP fire communicators are single or dual path commercial fire alarm communicators that offer Contact ID reporting with any FACP (fire alarm control panel) with a built-in dialer.

Models include:

HWF2A-COM (AT&T LTE & IP)

HWF2V-COM (Verizon LTE & IP)

Both models connect directly to the primary or secondary communication ports of a fire panel's digital alarm communicator transmitter (DACT).

Three selectable reporting paths include: LTE cellular only, IP only, or IP primary with LTE cellular backup. All signals from the HWF2-COM Series are delivered to the AlarmNet® network control center which routes highly encrypted, cybersecured Ethernet data packets via a customer-provided Internet connection or LTE cellular network to the appropriate central station. The AlarmNet® network control center is fully redundant and monitored 24/7. Installation and programming are easy using the handheld 7720P Programming tool.



FEATURES AND BENEFITS

- LTE and IP connection tested every day
- Three selectable reporting paths: LTE cellular only, IP only, or IP Primary with LTE cellular backup
- Requires no change to the existing FACP configuration
- Connects directly to the primary and secondary telephone ports of a DACT
- Plan choices range from 5 minute, 60 minute, 6 hour, and 24 hour supervision intervals
- Operates over the following communication protocols: LTE, HSPA+(4G) HSPA (3G)
- Works over any type of customer provided Ethernet 10/100 based network
- connection (LAN or WAN), DSL modem or cable modem
- Data transmits over standard Contact ID protocol but is secured with the industry's advanced encryption standard (AES 256 bit)
- Supports both dynamic (DHCP) or public and private Static IP addressing
- Reliable connection: IP and cellular connection tested every day
- Built-in, standalone power supply module. Onboard charging circuit design accommodates battery backup. Includes primary power and battery supervision
- Diagnostic LEDs indicate signal strength and status
- Choice of LTE provider services
- QOS: Quality of Service diagnostics via AlarmNet conveys vital communicator information including signal strength, message path used, and when the message was received
- 7720P Handheld programmer for easy setup

Honeywell

The HWF2-COM LTE / IP fire communicators operate over the most modern and common cellular networks including LTE, 4G and 3G.

They connect to any customer provided Ethernet 10/100 base network connection (LAN or WAN), DSL or cable modem. Selectable reporting path feature allows the radios to be configured for a single or dual path, while providing appropriate supervision intervals based on NFPA 72 requirements. Selectable paths and supervision timing intervals include:

SELECTABLE PATH	DESCRIPTION	SUPERVISION TIMES
2010 Cell	Single path, cellular	5 Minutes
2010 IP	Single path, IP	5 Minutes
2010 IP & Cell	Dual path, IP and cellular	24 Hours
2013 Cell	Single path, cellular	60 Minutes
2013 IP	Single path, IP	60 Minutes
2013 IP & Cell	Dual path, IP and cellular	6 Hours

OPERATION

When an event occurs, the FACP goes off-hook to dial the central station. The HWF2-COM Series dialer capture module detects the off-hook condition and provides the fire panel with a dial tone. When the fire panel detects the dial tone, it begins dialing the central station.

After the dialing is completed, the dialer capture module returns a signal to the fire panel. The fire panel then sends the Contact ID reports to the dialer capture module, which in turn sends a signal after the report is successfully received from the fire panel. The dialer capture module sends the Contact ID reports to the HWF2-COM Series communications module. When all the reports are sent, the fire panel goes on-hook. The HWF2-COM Series communications module then transmits the messages to the central station either over the LTE network or the Internet (depending on configuration).

FIRE COMMUNICATOR / PANEL CAPABILITY

The HWF2-COM Series is compatible with fire alarm control panels that use the Contact ID communications format as described in the SIA DC-05 standard.

EASY TO PROGRAM

The HWF2-COM communicator can be pre-programmed using the 7720P programmer to enter all central station information. This is saved to the HWF2-COM communicator panel memory. When the HWF2-COM is installed at the site and connected to the Internet/ Intranet, it registers with the AlarmNet Receiver.

For most installations, the only required parameters are:

- Primary City ID (two digits), obtained from your monitoring station
- Primary Central Station ID (two digits), obtained from your monitoring station

- Primary Subscriber ID (four digits), obtained from your monitoring station
 - Communication Module MAC ID, and MAC CRC number located on the outside of the box and inside of the module
- All parameters are assigned by the monitoring station.

ALARMNET

AlarmNet communications technology provides a highly reliable alternative for the transmission of alarm signals. The network provides extensive coverage in the United States and Canada. The AlarmNet Network Control Center processes signals from powerful servers in multiple locations equipped with 24/7 infrastructure support. Redundant hardware servers, real-time backup databases, and generators with battery backup at all locations ensure continuity of service. Signals from AlarmNet are transmitted to central station receivers using multiple communication paths consisting of the Internet, LTE radio network, or toll free plain old telephone service (POTS). Visit AlarmNet.com to learn more.

INSTALLATION REQUIREMENTS, UL COMPLIANCE

To meet UL864/NFPA requirements, ensure the following:

- HWF2-COM Series must be installed in accordance with the National Fire Protection Association (NFPA) standards 70 and 72
- HWF2-COM Series must be mounted in the same room and within 20 feet of the fire panel.
- HWF2-COM Series and all equipment used for the IP connection (e.g., router, hub, modem, etc) must be UL-listed, powered from an unswitched branch circuit, and be provided with appropriate standby power.
- HWF2-COM Series must use the 7AH battery (not included) to provide 24 hour backup capability

HWF2-COM SERIES TECHNICAL SPECIFICATIONS

ELECTRICAL

Transformer:

- Primary: 120VAC, 60Hz, 0.5A
- Secondary: 18VDC, 50VA

Battery:

- One 12 V 7.0 AH lead-acid battery: (not supplied)
- Battery charging current: 1 Amp maximum
- Battery discharge current: Standby 230mA, Active 950mA

CABINET SPECIFICATIONS

- Dimensions: 14.875" H x 12.75" W x 3.0" D (37.8cm H x 32.4cm W x 7.6cm D)
- Color: Red

SHIPPING DIMENSIONS

- Weight: 5.3 lbs (6.94kg)
- Dimensions: 15.625" H x 13.79" W x 9.25" D (39.7cm H x 34.9cm W x 23.9cm D)

TEMPERATURE AND HUMIDITY RANGES

This system meets NFPA requirements for operation at 0 - 49°C/32-120°F and at a relative humidity 93%+- 2% RH (non-condensing at 32°C +- 2°C(90°F +-3°F). However the useful life of the system's standby batteries and the electronic components may be adversely affected by extreme temperature ranges and humidity. Therefore, it is recommended that this system and its peripherals be installed in an environment with a normal room temperature of 15 - 27°C/60-80°F.

PRODUCT LINE INFORMATION

HWF2V-COM: LTE Digital Cellular Fire Alarm Communicator and Internet Panel, Verizon LTE / IP

HWF2A-COM: LTE Digital Cellular Fire Alarm Communicator and Internet Panel, AT&T LTE / IP

Both models include:

- Red cabinet with key and lock
- Wall outlet box
- Dialer capture module
- LTE communications module
- Antenna and mounting adapter
- PowerBoost1 power supply
- LED display board
- Transformer
- Manual and required screws
- Cables, etc.

ANTENNA AND EXTERNAL HARDWARE

CELL-ANT3DB: 3dBA gain antenna
WA7626-CA: SMA to N adapter cable
7626-50HC: 50 ft. antenna cable, low loss

Note: The WA7626-CA adapter cable and 7626-50HC antenna cable are only required when installing the CELL-ANT3DB antenna remotely.

OTHER ACCESSORIES

7720P: HWF2V-COM, HWF2A-COM and IPGSM-4G handheld programmer

HPTCOVER: Plug-in transformer box for HWF2V-COM, HWF2A-COM, and IPGSM-4G communicators

BAT-1270: Battery 12 Volts, 7AH, sealed

AGENCY LISTINGS AND APPROVALS

The listings and approvals below apply to the HWF2-COM Series communicators. In some cases, certain modules may not be listed by certain approval agencies, or listing may be in process. Consult the factory for latest listings.

UL Listed: S789

CSFM: 7300-1645:0511

FDNY: Approved

AlarmNet® is a registered trademarks of Honeywell International Inc.

©2019 by Honeywell International Inc. All rights reserved.

Unauthorized use of this document is strictly prohibited.

This document is not intended to be used for installation purposes. We try to keep our product information up-to-date and accurate. We cannot cover all specific applications or anticipate all requirements. All specifications are subject to change without notice.

Country of origin: USA

Honeywell Power Products

12 Clintonville Road
Northford, CT 06472-1610
203.484.7161
www.honeywellpower.com

DH-62010 | B | 06/19
©2019 Honeywell International Inc.

THE
FUTURE
IS
WHAT
WE
MAKE IT

Honeywell

HWF2V-COM HWF2A-COM

Commercial Fire Communicator

Installation and Setup Guide

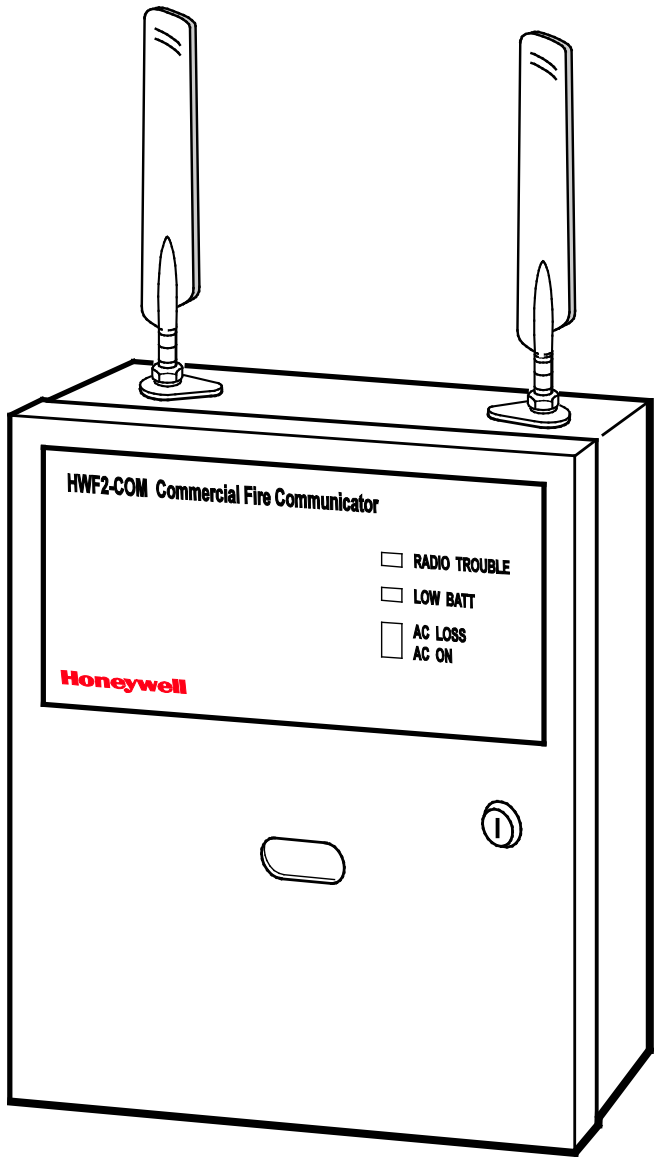

Table of Contents

General Information	1
Package Contents	1
Compatible Fire Panels	1
Operation	1
Installation.....	1
UL Compliance.....	1
Programming for UL864 Compliance.....	2
STEP 1 – Determine the Signal Strength and Select a Location	2
STEP 2 – Mount and Wire	3
STEP 3 – Program the Communicator.....	5
Using the AlarmNet 360 Website	5
Setting Factory Defaults	6
STEP 4 – Register the Communicator with AlarmNet.....	7
Registering through the AlarmNet 360 Website.....	7
Register using the Tamper Switch.....	7
Register using the Programming Tool	7
Replacing an existing communicator.....	8
Register by Phone.....	9
STEP 5 – Configure the Fire Panel	9
STEP 6 – Test the System.....	9
Dialer Capture Module Information	10
LED Display Information	10
Programmer Keyboard Commands	11
Identification Displays	11
Cellular Status Displays (appear only if the communication path includes cell)	12
LTE Displays	13
System Status Displays	15
Running Network Diagnostics.....	16
Possible Errors Running Network Diagnostics.....	17
PowerBoost1 Information.....	18
Communicator Information.....	19
RF Specifications	20
Central Station Messages.....	20
Alarm Condition.....	20
Trouble Reporting:.....	20
AlarmNet Messages	20
HWF2-COM Trouble Detection Information	21
Fault Condition	21
HWF2-COM Specifications	21
Wiring Diagram	Inside of Back Cover

General Information

The HWF2-COM Commercial Fire Communicator (henceforth referred to as HWF2-COM) is a commercial Fire Alarm communicator that allows a Fire panel that previously reported by POTS to be upgraded to a system that uses the internet or cellular means to connect to a central station.

This dual path communicator connects directly to the primary and secondary communication ports of a Fire panel's Digital Alarm Communicator Transmitter (DACT). It offers three selectable reporting paths which include; Cellular only, IP only, or IP primary/cellular backup. In addition, the communicator's power module (PowerBoost1) monitors and reports AC power loss, and low battery conditions. All signals from the HWF2-COM communicator panel are delivered to Honeywell's AlarmNet Network Control Center, which routes the information to the appropriate central station.

Package Contents

- Red Fire Cabinet and Back Plate
- Two Antennas, Mounting Adapters and 50-ohm (9.5in) coaxial cable assemblies
- LED Display board
- Cam Lock with Key
- PowerBoost1
- Mounting Rails (for above)
- Dialer Capture Module
- Battery harness
- Hardware Bag
- Communicator
- Wall Outlet Box (P/N K14358)
- Transformer, 18VAC (N8167-1)
- Ferrite Filter

Compatible Fire Panels

The HWF2-COM is compatible with Fire Panels that use the Contact ID communication format as described in the SIA DC-05 Standard.

NOTE: The HWF2-COM **ONLY** supports ECP mode due to the communication with the built in DCID. The 4204, 2-4204, or Zone modes are **NOT** a supported feature.

After completing the field installation, verify communications with the central station is successful by sending several events. Also, get confirmation that these events were received.

Operation

The HWF2-COM replaces the fire panel's POTS communications path. When an event occurs, the fire panel goes off-hook to dial the central station. The HWF2-COM detects the off-hook condition and provides the fire panel with a dial tone. When the fire panel detects the dial tone, it begins dialing the central station. The HWF2-COM considers the three second period after dialing as the number dialing has been completed. After the dialing is completed, the Dialer Capture Module returns a handshake to the fire panel.

The fire panel then sends the contact ID reports to the HWF2-COM, which in turn sends a kiss-off after the report is successfully received from the fire panel. Within the HWF2-COM, the Dialer Capture Module sends the contact ID reports over the ECP bus to the Communicator. When all the reports are sent, the fire panel goes on-hook. The HWF2-COM then transmits the messages to the central station (either over the internet or the cellular network).

Installation

UL Compliance

To meet UL864/NFPA, ensure the following:

- HWF2-COM must be installed in accordance with NFPA (National Fire Protection Association) standards 70 and 72.
- HWF2-COM must be mounted in the same room and within 20 feet of the fire panel.
- The Telco line wiring and the Power Transformer wiring must be routed through conduit.
- HWF2-COM, and all equipment used for the IP connection (such as the router, hub, modem, etc.) shall be UL Listed, must be powered from an un-switched branch circuit, and be provided with appropriate standby power.
- HWF2-COM must use a 7AH battery (not supplied) to provide 24-hour backup capability.

Programming for UL864 Compliance

The HWF2-COM Commercial Fire Alarm Communicator provides a programmable supervision feature that allows the system to meet the UL864 Commercial Fire requirements. These requirements are in the following table.

NOTICE TO USERS, INSTALLERS, AUTHORITIES HAVING JURISDICTION AND OTHER INVOLVED PARTIES				
This product incorporates field programmable software. In order to comply with the requirements in the standard for control units and accessories for Fire Alarm Systems, UL 864 certain programming features or options must be limited to specific settings or not used at all as indicated below.				
Selected Com. Path	Supervision Interval	IP Fault Time	Cell Fault Time	UL864 Compliant?
2010 Cell	5 minutes	N/A	5 minutes	N
2010 IP	5 minutes	5 minutes	N/A	N
2010 IP & Cell	24 hours	1 hour	1 hour	N
2013 Cell	1 hour	N/A	1 hour	Y*
2013 IP	1 hour	1 hour	N/A	Y*
2013 IP & Cell	6 hours	1 hour	1 hour	Y*

* Only the indicated setting is compliant. Any other value in this field will not meet UL864 Commercial Fire requirements.

STEP 1 – Determine the Signal Strength and Select a Location

IMPORTANT - Do Not mount this device outdoors.

RF Exposure

Warning - The internal or external antenna(s) used by this product must be installed to provide a separation distance of at least 7.8 in. (20 cm) from all persons and must not be co-located or operating in conjunction with any other antenna or transmitter except in accordance with FCC multi-transmitter product procedures.

* **HWF2-COM Initial Power Up:** Upon initial power up, the communicator LEDs blink in repeated sequence from top to bottom indicating network initialization.

Green (REG) → Yellow (TX/RX) → Red (FAULT)

This sequence may take up to 15 minutes. **Do not reset power during this time.**

When initialization is complete, the Signal Quality display LEDs will light and the yellow and red LEDs may blink (per their respective functions).

After initial network setup, subsequent resets or power ups can take up to 90 seconds.

When choosing a suitable mounting location, understand that signal strength is very important for proper operation. For most installations using the supplied antenna, mounting the unit as high as practical, and avoiding large metal components provides adequate signal strength for proper operation.

In this procedure you will use the Communicator to determine signal strength in order to find a suitable mounting location.

1. For this procedure you will need a fully charged 12V battery.
2. Attach the Antenna Mounting Adapters, 50-ohm (9.5in) coaxial cables, and Antennas (see illustration on page 4).
3. Temporarily wire the battery's negative [-] terminal to TB1-4 on the communicator, then wire the battery's plus [+] terminal to TB1-2 on the communicator. Wait about one minute for the communicator to initialize.
4. Position the assembly near a suitable mounting position and observe the signal quality display.
5. Look for a mounting position that yields at least 2 bars lit solid. For optimal performance 4 or 5 bars are better.
6. Verify the signal quality remains steady for a few minutes, then mark that mounting position. Disconnect the battery.

STEP 2 – Mount and Wire

- For UL compliant installations, refer to the topic on *UL Compliance* in this manual.
- For UL compliant installations, the Telco line wiring and the Power Transformer wiring must be routed through conduit.
- For Dry/Indoor use only.
- Unless otherwise specified, use 18AWG.
- Additional cabinet wiring may be routed through conduit if desired.

This communicator comes partially assembled with all the components mounted except the external Antennas, LED Display board, and PowerBoost1. To protect certain components on the PowerBoost1, it is shipped un-mounted. All internal wiring is complete.

NOTE: Refer to the diagram on page 5, and to the Wiring Diagram on the inside of the back cover of this manual for wiring and component identification.

1. Remove knockouts from cabinet to accommodate the power input wires, and wiring to the fire panel. Then mount the cabinet securely to the wall using 4 screws or bolts. Use mounting screws or bolts that are suitable for the material being anchored to.
2. Ensure the cabinet door lock is installed.
3. Install the two plastic mounting rails for the LED Display board. They simply snap into the back plate holes.
4. Connect the LED Display board to its connector, then slide the board into the mounting rails. (Yellow LED and Buzzer are on top.)
5. Carefully remove the packaging material that surrounds the PowerBoost1.
6. Mount the PowerBoost1 on the three unused standoffs. Use the two metal screws and lock washers to fasten the left side of the circuit board. Ensure the lock washers are located between the circuit board and the head of the two metal screws. The right side of the board just snaps in place on the upper right standoff.
7. Mount the Wall Outlet Box to an un-switched facility power outlet and run a conduit to the cabinet.
8. **In this step DO NOT plug the transformer in.** Route wire (minimum 18AWG) from the transformer, through the conduit and into the cabinet. Pass the wires through the Ferrite Filter, then loop the wires back through again making a loop. Connect the wires to the PowerBoost1 AC terminals.

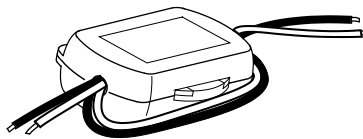

9. Connect and route 16AWG insulated wire from facility power ground (typically a cold water pipe) to the cabinet's ground post. Ensure all ground connections are tight.
10. Connect the Ethernet cable and the Telco 1 and Telco 2 lines. If you choose to use an optional Cabinet Tamper Switch (if the fire panel supports it) mount and wire it.
11. Verify the PowerBoost1 DIP switches are configured as shown below.

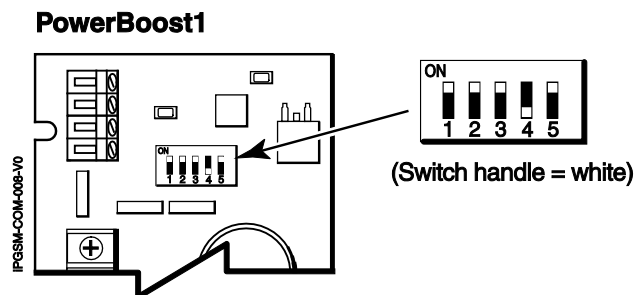

12. Ensure the following:

- LED Display board is fully seated.
- All wiring terminals and connectors are tight.
- All wiring has been completed and secured with cable ties.

13. Install the battery (not supplied). Plug the power transformer in, and attach the battery cable.

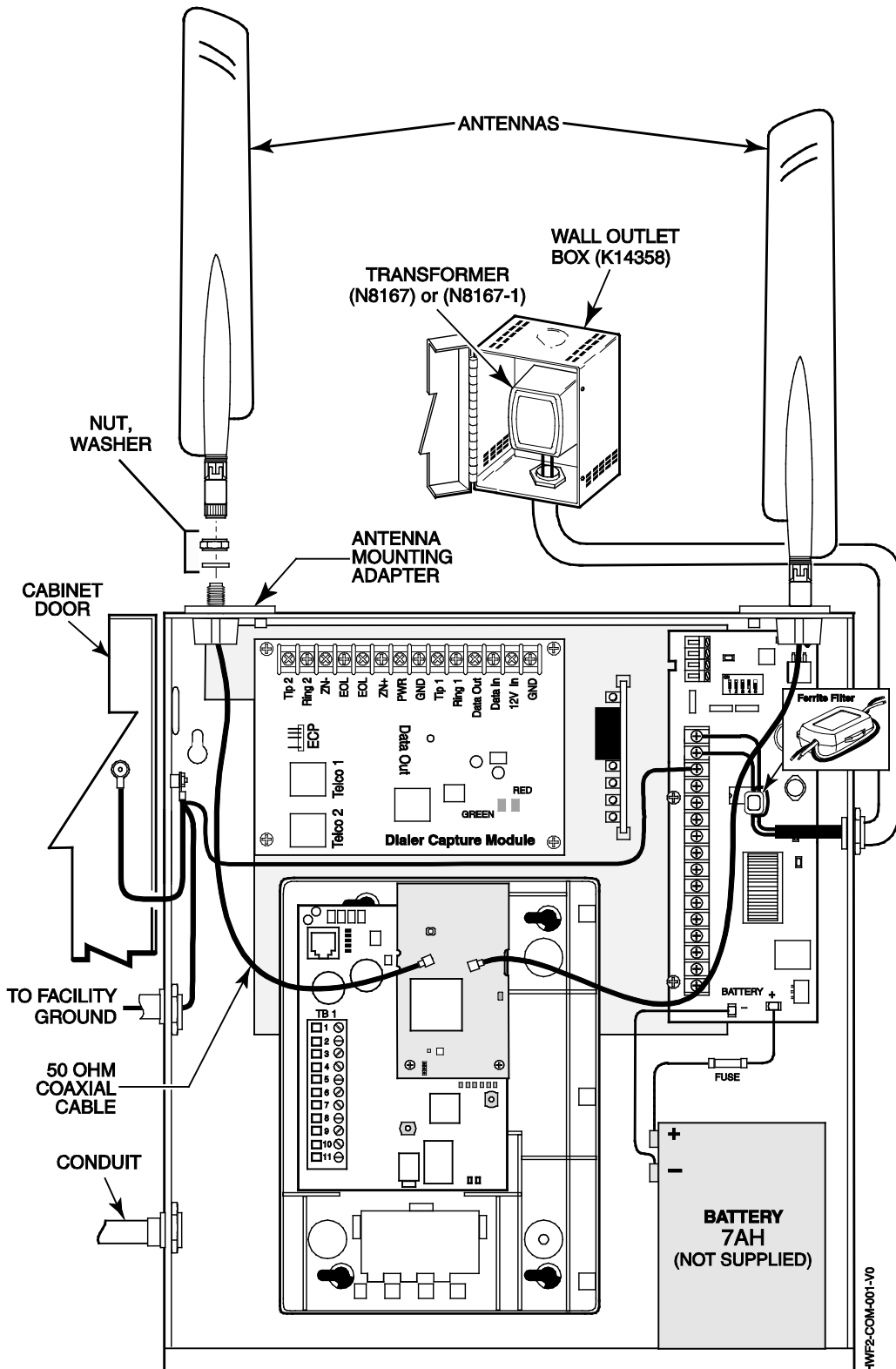

Wiring for Grounds, Power, and RF

STEP 3 – Program the Communicator



The HWF2-COM requires an AlarmNet account. For new installations, please obtain the account information from the central station prior to programming.

You can program the communicator by one of the following methods:

- Using the AlarmNet 360 website.
- Using the 7720P Programming Tool.
- Using the control panel's programming mode (for panels that support this option) to access the communicator's programming.

NOTE: The prompts in this document reflect use of the 7720P Programming Tool.

Using the AlarmNet 360 Website

To program the communicator via the website (if you are already signed up for this service), go to: www.alamnet360.com

Please have the following information available when programming the communicator:

- Primary City ID (two-digit number), obtained from your monitoring station.
- Primary Central Station ID (two-digit number), obtained from your monitoring station.
- Primary Subscriber ID (four-digit number), obtained from your monitoring station.
- Communicator's MAC ID and MAC CRC number (located on the box and inside the communicator).

After programming is complete, the communicator must be registered. Refer to the **Register the Module** topic.

When using the 7720P Programming tool, the values given below are for most installations. Press the [#] key to accept the displayed default value (xxx) or enter the new value and press the [#] key for the next prompt. Use the [Space] key to scroll through a list of options.

1.	Connect the 7720P. (You can use the [Shift + A] key to check the software revision.)																												
2.	<input type="text" value="7720P PROGRAMMER"/> Press [#].																												
3.	<input type="text" value="Start Prog Mode? Y/N"/> Press [Shift] then [Y], then [#].																												
4.	<input type="text" value="Program Device? Y/N"/> Press [Shift] then [Y], then [#].																												
5.	<input type="text" value="Com Path Choice (IP & Cell)"/> Press [Space] to scroll choices; IP&Cell, IP, or Cell. Press [#] to select.																												
	<p>NOTE: The 2013 choices have been evaluated to meet NFPA 2013 supervision requirements and are subject to approval by the local authority having jurisdiction.</p> <table border="1"> <thead> <tr> <th>Choice</th> <th>Supervision Interval</th> <th>IP Fault Time</th> <th>Cell Fault Time</th> </tr> </thead> <tbody> <tr> <td>2010 IP & Cell</td> <td>24 hours</td> <td>1 hour</td> <td>1 hour</td> </tr> <tr> <td>2013 IP</td> <td>1 hour</td> <td>1 hour</td> <td>---</td> </tr> <tr> <td>2013 Cell</td> <td>1 hour</td> <td>---</td> <td>1 hour</td> </tr> <tr> <td>2013 IP & Cell</td> <td>6 hours</td> <td>1 hour</td> <td>1 hour</td> </tr> <tr> <td>2010 IP</td> <td>5 minutes</td> <td>5 minutes</td> <td>---</td> </tr> <tr> <td>2010 Cell</td> <td>5 minutes</td> <td>---</td> <td>5 minutes</td> </tr> </tbody> </table>	Choice	Supervision Interval	IP Fault Time	Cell Fault Time	2010 IP & Cell	24 hours	1 hour	1 hour	2013 IP	1 hour	1 hour	---	2013 Cell	1 hour	---	1 hour	2013 IP & Cell	6 hours	1 hour	1 hour	2010 IP	5 minutes	5 minutes	---	2010 Cell	5 minutes	---	5 minutes
Choice	Supervision Interval	IP Fault Time	Cell Fault Time																										
2010 IP & Cell	24 hours	1 hour	1 hour																										
2013 IP	1 hour	1 hour	---																										
2013 Cell	1 hour	---	1 hour																										
2013 IP & Cell	6 hours	1 hour	1 hour																										
2010 IP	5 minutes	5 minutes	---																										
2010 Cell	5 minutes	---	5 minutes																										
6.	<input type="text" value="Primary City ID (??)"/> Enter number 01-99, then press [#].																												
7.	<input type="text" value="Primary CS ID (??)"/> Enter number 01-FE, then press [#].																												
8.	<input type="text" value="Primary Sub ID (????)"/> Enter number 0001-9999, then press [#].																												
9.	<p><input type="text" value="Cell Fit Time (60 mins)"/> This prompt appears only if comm. path includes IP&Cell or Cell. Enter the time delay (1 – 60) in minutes before the communicator notifies the control there is a communication path failure to AlarmNet over cell. If the panel has an alternate communication path, a secondary path loss message is sent to the central station.</p> <p>NOTE: Refer to table above for correct default values.</p>																												

10.	IP Flt Time (60 mins) NOTE: Refer to table above for correct default values.	This prompt appears only if comm. path includes IP&Cell or IP. Enter the time delay (1 – 60) in minutes before the communicator notifies the control panel that there is a communication path failure to AlarmNet over the hard-wired Ethernet connection. If the panel has an alternate communication path, a primary path loss message is sent to the central station.
	NOTES: <ul style="list-style-type: none"> • Changing the comm. path choice will cause the fault times to default to the values listed in the table in prompt 5 • The control is notified of the failure after the Cell and/or IP fault times expire • Refer to page two for UL864 Compliance programming requirements 	
11.	Use DHCP? Y/N (Y)	If your router is configured for DHCP, press [Shift] then [Y], then press [#].
	NOTE: If DHCP is not selected (your router is set for a static IP), prompts 10 through 13 will appear. Use the [Space] key to advance to the next address part.	
12.	NIC IP Address: 255.255.255.255	Enter choice, then press [#]. Follow the prompts.
13.	Subnet Mask: 255.255.255.255	Enter choice, then press [#]. Follow the prompts.
14.	Gateway IP Address: 255.255.255.255	Enter choice, then press [#]. Follow the prompts.
15.	DNS Serv IP Addr: 255.255.255.255	Enter choice, then press [#]. Follow the prompts.
16.	Review? Y/N	Enter choice, then press [#]. Follow the prompts.
17.	Create Password? Y/N	Enter choice, then press [#]. Follow the prompts.
18.	Exit Prog Mode? Y/N	Press [Shift] then [Y], then press [#]. DONE.

NOTE: If an error in programming occurs, set the factory defaults (see next topic) and reprogram.

To exit the programming mode, press [N] in response to the "Review?" prompt. Then press [Y] to the "Exit Prog Mode?" prompt. Upon exiting, the root file is updated to log the changes made. A message is displayed telling the user that this step is being executed. When complete, the message "DONE" is displayed to indicate the file was successfully uploaded.

NOTE: If critical configuration changes were made, such as the mode of operation, the communicator will reset to ensure that the programming features are enabled.

If the file is not successfully uploaded, one of the following prompts will be displayed. Follow the steps shown below until the upload is successful.

Display	Description	What to do
Cannot Upload Try Again? Y/N_	Communicator is not yet initialized.	Wait for signal quality indicator LEDs to be lit. Press [Y].
Failed to Update Root File!	Network problem, or you answered "N" to "Cannot Upload Try Again?" prompt.	Initiate the Force Server Update Command by pressing the [0] key.

Setting Factory Defaults

To reset the programming options to factory-default values, at the "Exit Prog Mode?" prompt press [Shift] plus [ESC]. **NOTE,** setting the factory defaults will also erase any password that may have been entered.

Set Default? Y/N_	Press [Y] to reset factory default values. Press [N] to cancel this function.
----------------------	--

Press [Shift] then [Y], then [#]. The Create Password prompt appears, follow the prompts then exit.

STEP 4 – Register the Communicator with AlarmNet

Once you have programmed the communicator, it must be registered to enable the AlarmNet account. Registering the communicator activates the account with AlarmNet and enables the security system's control panel to send reports. You can register by using one of the following methods:

- AlarmNet 360 website
- 7720P Programming Tool
- Test Message/Registration switch
- Phone

You can monitor the registration process by viewing the display LEDs. The TX/RX (yellow) LED and the REG (green) LED will blink slowly in unison while registration is in progress.

When the registration successfully completes, the communicator enters a normal operating mode; the REG (green) LED goes out and the TX/RX (yellow) LED is lit to indicate that the power-on / reset message is waiting to be sent. This message will appear at the receiving station as "E339 803". The description may read "Trouble – Exp. Mod. Reset". If registration is not validated within 90 seconds, the communicator times out, and the REG (green) LED will be lit solid.

Registering through the AlarmNet 360 Website

To register the communicator via the website, go to: www.alarmnet360.com.

Log in and follow the on-screen prompts.

Please have the following information available:

- Primary City ID (two-digit number).
- Primary Central Station ID (two-digit hexadecimal number).
- Primary Subscriber ID (four-digit number).
- MAC ID and MAC CRC number (located on the box and inside the communicator).

After the communicator is registered, you may log out of the AlarmNet 360 website.

Register using the Tamper Switch

Initiate the registration sequence by clicking the Tamper Switch three times.

You can monitor the registration process by viewing the Status Display. The Message (yellow) LED and the Status (green) LED will blink slowly in unison while registration is in progress.

Once the registration has been completed successfully, the communicator enters normal operating mode; the Status (green) LED goes out and the Message (yellow) LED is lit to indicate that the Power On / Reset message is waiting to be sent. This message will appear at the receiving station as "E339 C08xx", where "xx" is the ECP device address. The description may read "Trouble – Exp. Mod. Reset". If registration is not validated within 90 seconds, the communicator times out, and the (green) LED will be lit (solid).

The Power On / Reset message will be sent in ADEMCO High-Speed format if the communicator is programmed for zone trigger mode.

If repeated registration attempts time out, check your Internet connection and signal quality level, and verify the communicator account information has been entered correctly.

Register using the Programming Tool

The interactive registration feature allows the installer to register the communicator through a series of keyboard commands on the 7720P Programming Tool. This method of registration lets the installer monitor the registration process.

Registering ...

Once the installation is complete, press the [Shift] and the up arrow [↑] key on the 7720P. The registration message is sent and the unit waits for the acknowledgment.

Registration
SUCCESS

If this is a new installation and the city, central station, and customer numbers have been correctly entered, the communicator is registered and this message is displayed. The communicator is now in full service and available for alarm reporting to the central station.

Possible Errors

Registration BAD
Timed Out

Displayed if no response to the registration request is received.

Registration BAD
Pri Sub ID BAD

Indicates the city, central station, or customer number for the labeled account(s) is not accepted. The ID information was either entered incorrectly, or the central station failed to pre-authorize programmed ID numbers with AlarmNet customer service.

Registration BAD
2nd Sub ID BAD

Indicates the city, central station, or customer number for the Secondary account is not accepted. The ID information was either entered incorrectly, or the central station failed to pre-authorize programmed ID numbers with AlarmNet customer service.

Registration BAD
Pri&Sec – IDs BAD

Displayed when both primary and secondary subscriber IDs are invalid.

Registration BAD
Pri ID – Need PIN

Displayed if this is a repair/replacement, or an error was made in programming the Primary account information of the communicator for an existing account. This prompt appears for 2 seconds. See the *Replacing an existing communicator* section below for further displays.

Registration BAD
2nd ID – Need PIN

This prompt is displayed if this is a repair/replacement, or an error was made in programming the Secondary account information of the communicator for an existing account. This prompt appears for 2 seconds. See the *Replacing an existing communicator* section below for further displays.

Registration BAD
Pri&2nd – Need PIN

This prompt is displayed if this is a repair/replacement, or an error was made in programming BOTH the Primary and Secondary account information of the communicator for an existing account. This prompt appears for 2 seconds. See the *Replacing an existing communicator* section below for further displays.

Replacing an existing communicator

Enter PIN#

This prompt appears after pressing the [Shift] and down arrow [↓] on the 7720P.

Note: If it is necessary to exit registration mode, press ESC from the 7720P programming tool.

Enter a 4-digit alphanumeric PIN number provided by your central station, your dealer or an authorized AlarmNet representative.

Press the [Enter] key.

Registering ...

The registration message is sent and the unit waits for acknowledgement.

Registration
SUCCESS

If the PIN is valid, the new communicator is registered and the old unit unregistered. Additionally, AlarmNet sends a substitution alarm to the central station.

Registration BAD

If you entered an invalid PIN, the appropriate message is displayed depending on which account number is being replaced (see above for exact wording). The registration process is repeated.

NOTE: Each attempt causes a substitution alarm to be sent to the central station.

Register by Phone

You can register the communicator by calling the AlarmNet Technical Assistance Center (TAC) at 1-800-222-6525. You will need the following information:

- MAC number (found on the box and inside the communicator).
- Subscriber information (provided by the central station), including a city code, CSID, and a subscriber ID.
- When instructed to do so, triple-click the tamper switch to complete the registration.

STEP 5 – Configure the Fire Panel

1. Ensure the Phone Line Supervision (or Telco Fault) on the panel is enabled. Then choose a setting that is no higher than 90 seconds (or as close to that) as the panel allows.
2. Ensure no more than 1 pause character (usually a comma) is programmed into the dialing string (usually 2 seconds). **NOTE**, this is necessary since the Dialer Capture Module waits only 3 seconds after the phone number is dialed. Having more than 3 seconds of pause time will cause it to think the phone number is complete and cause it to generate the high-low tones at an incorrect moment.

STEP 6 – Test the System

1. Close the Wall Outlet Box, then close and lock the cabinet cover.
2. Refer to the fire panel's installation/operation guide the testing procedure.
3. (Notify the monitoring station that a test will be conducted.) Test the system to ensure it is operating.
4. Verify communications with the monitoring station is successful by sending several events. Also, get confirmation that these events were received.

Dialer Capture Module Information

LED Indicator	STATUS
RED – Steady ON	Messages exist in buffer.
RED – Flashing	No messages to be sent. Waiting for messages.
GREEN – Steady ON	Normal Indication.
GREEN – Blinks every 2 sec.	PowerBoost1 communication problem.
GREEN – Blinks twice every sec.	Connection with the Communicator is lost.
GREEN – Blinks 10 times every sec.	PowerBoost1 and Communicator connections are lost.

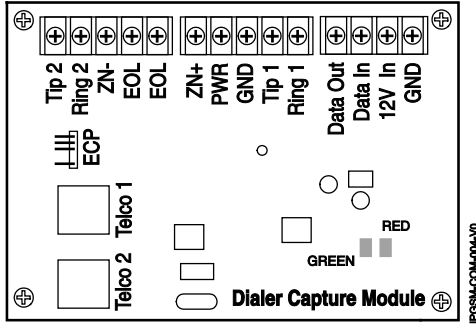

NOTE: Telco ports 1 (primary dialer) and 2 (secondary dialer) may be used instead of the terminal board.

Whichever connection method is used, both Telco paths must be connected to the Fire Panel.

LED Display Information

Status	LED Indicator
RADIO TROUBLE	Yellow – ON when radio trouble is present. <ul style="list-style-type: none"> Both IP and Cell communication paths are lost. Communicator radio is not registered. Old Alarm Time has been exceeded. (Message has not been delivered within the fixed 10-minute window.)
	Buzzer – Upon loss of AC power, this will beep once every 10 seconds.
LOW BATTERY	Yellow – ON when battery is low (<11.5VDC).
	Yellow – (not used)
AC LOSS	Yellow – ON when no AC is present (< 90VAC).
AC ON	Green – ON when AC is present.

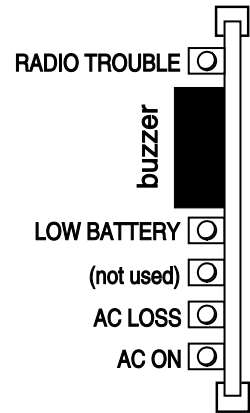

NOTE: If a wire pulled out of the LED Board Connector refer to the diagram on right and reinsert wire, ensuring the connector pin is locked in.

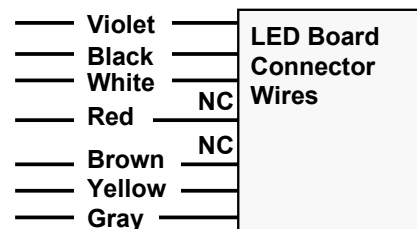

Programmer Keyboard Commands

Programmer keyboard commands can be used to quickly view your connectivity settings and options. Most commands require you to press the [Shift] key and then the designated command key. (See the keys designated in red on the 7720P Programming Tool.)

[A]	<pre> HWF2V-COM x.x.xx mm/dd/yy </pre>	<p>Software Revision "x.x.xx" indicates the installed software Revision. Mm/dd/yy indicates month, day and year of the revision.</p>
[A]	<pre> HWF2A-COM x.x.xx mm/dd/yy </pre>	<p>Software Revision "x.x.xx" indicates the installed software Revision. Mm/dd/yy indicates month, day and year of the revision.</p>

Identification Displays

[B]	<pre> MAC xxxxxxxxxxxx MAC CRC yyyy </pre>	<p>MAC Address "xxxxxxxxxxxx" indicates the communicator's unique identification number. "yyyy" indicates the MAC CRC number. This number is found on the box and inside the communicator. Press the [Space] key to go to the next field. Press the backspace [BS] key to go to the IMEI display (if the communication path includes cell).</p>
		<p>NOTE: The SCID and IMEI are displayed only if the communication path includes cell.</p>
	<pre> SCID xxxxx xxxxx xxxxx xxxxx </pre>	<p>SCID Display Displays the identification number assigned to the SIM card (SCID) in this device. Press the [Space] key to go to the next field. Press the backspace [BS] key to go to the previous field.</p>
	<pre> IMEI xxxxxxxx xxxxxx x </pre>	<p>IMEI Display Displays the identification number assigned to the communicator. Press the [Space] key to get the MAC Address. Press the backspace [BS] key to go to the previous field.</p>
[C]	<pre> Mon 01 Jan 2001 05:48:39 am </pre>	<p>Time Retrieves the current date and time from the AlarmNet network in Greenwich Mean Time (GMT). This display confirms that the communicator is in sync with network.</p>

NOTE: The following displays except Encryption Test are displayed only if the communication path includes IP.

[D]	<div style="border: 1px solid black; padding: 2px;">Physical Link Good/Bad</div>	<p>Network Diagnostics Display Indicates whether the device has detected a physical connection to the internet. Press the [Space] key to go to the next field.</p>
	<div style="border: 1px solid black; padding: 2px;">NIC IP Address xxx.xxx.xxx.xxx</div>	<p>IP Information Display Displays the IP address assigned to this device. Press the [Space] key to go to the next field.</p>
	<div style="border: 1px solid black; padding: 2px;">Subnet Mask xxx.xxx.xxx.xxx</div>	<p>Displays the 32-bit address mask used to indicate the portion (bits) of the IP address that is being used for the subnet address. Press the [Space] key to go to the next field.</p>
	<div style="border: 1px solid black; padding: 2px;">Gateway IP Addr xxx.xxx.xxx.xxx</div>	<p>Displays the IP address assigned to the Gateway. Press the [Space] key to go to the next field.</p>
	<div style="border: 1px solid black; padding: 2px;">DNS Serv IP xxx.xxx.xxx.xxx</div>	<p>Displays the IP address assigned to the DNS (Domain Name System) server. Press the [Space] key to go to the next field.</p>
	<div style="border: 1px solid black; padding: 2px;">Encryption Test AES Passed!</div>	<p>Performs a self-test of the AES encryption algorithm. Press the [Space] key to go to the next field.</p>
	<div style="border: 1px solid black; padding: 2px;">DHCP OK</div>	<p>DHCP (Dynamic Host Configuration Protocol) indicates server is performing satisfactorily. Press the [Space] key to go to the Physical Link display.</p>

Cellular Status Displays (appear only if the communication path includes cell)

[E]	Operating with Cellular Service							
	<div style="border: 1px solid black; padding: 2px;"> <table style="width: 100%; border-collapse: collapse;"> <tr> <td style="text-align: left;">RAT</td> <td style="text-align: left;">SigQual</td> <td style="text-align: left;">REG</td> </tr> <tr> <td>LTE/3G</td> <td>*****</td> <td>x</td> </tr> </table> </div>	RAT	SigQual	REG	LTE/3G	*****	x	<p>Cellular Status Display Screen 1 RAT – Radio Access Technology. – LTE or 3G SigQual – Signal Quality (1-5 “**”) REG – Registration status where “x” can be: N – Not Registered H – Registered Home S – Searching D – Registration Denied R – Registered Roaming ? – Unknown Registration State</p>
RAT	SigQual	REG						
LTE/3G	*****	x						
	<p>Press the [space] key to go to the next screen.</p>	<p>If the RAT is LTE, the number of stars is derived from received power (RSRP) and the received quality (RSRQ). The lower number of stars of the two ratings is what is displayed as overall quality.</p>						
	<p>Press the [backspace] key to go to the last screen.</p>	<p>NOTE: For adequate signal strength, must be 2 stars or more.</p> <table style="width: 100%;"> <tr> <td style="width: 50%; vertical-align: top;"> <p>RSRP:</p> <p>Greater than -85dBm = 5 stars -86dBm to -95dBm = 4 stars -96dBm to -105dBm = 3 stars -106dBm to -115dBm = 2 stars -116dBm and lower = 1 star</p> </td> <td style="width: 50%; vertical-align: top;"> <p>RSRQ:</p> <p>Greater than -10dB = 5 stars -11dB to -12dB = 4 stars -13dB to -14dB = 3 stars -15dB to -16dB = 2 stars -17dB and lower = 1 star</p> </td> </tr> </table>	<p>RSRP:</p> <p>Greater than -85dBm = 5 stars -86dBm to -95dBm = 4 stars -96dBm to -105dBm = 3 stars -106dBm to -115dBm = 2 stars -116dBm and lower = 1 star</p>	<p>RSRQ:</p> <p>Greater than -10dB = 5 stars -11dB to -12dB = 4 stars -13dB to -14dB = 3 stars -15dB to -16dB = 2 stars -17dB and lower = 1 star</p>				
<p>RSRP:</p> <p>Greater than -85dBm = 5 stars -86dBm to -95dBm = 4 stars -96dBm to -105dBm = 3 stars -106dBm to -115dBm = 2 stars -116dBm and lower = 1 star</p>	<p>RSRQ:</p> <p>Greater than -10dB = 5 stars -11dB to -12dB = 4 stars -13dB to -14dB = 3 stars -15dB to -16dB = 2 stars -17dB and lower = 1 star</p>							

LTE Displays

RAT	RSRP	RSRQ
LTE	xxxx	xxxx

Signal Display for LTE

RAT – Radio Access Technology.
RSRP – Reference Signal Received Power
RSRQ – Reference Signal Received Quality
Press the [space] key to get to the next screen.
Press the [backspace] key to go to the previous field.

RSRP	MIN	MAX
xxxx	xxxx	xxxx

Min/Max Signal Display for LTE

RSRP – Current Reference Signal Received Power
MIN – Minimum Receive Signal Level
MAX – Maximum Receive Signal Level
Press the [space] key to get to the next screen.
Press the [backspace] key to go to the previous field.

RSRQ	MIN	MAX
xxxx	xxxx	xxxx

Min/Max Signal Quality Display for LTE

RSRQ – Current Reference Signal Received Quality
MIN – Minimum Receive Signal Quality
MAX – Maximum Receive Signal Quality
Press the [space] key to get to the next screen.
Press the [backspace] key to go to the previous field.

Cntry	Netw	TAC
xxx	xxx	xxxxx

Location Display for LTE

Cntry – Country Code
Netw – Network Code
TAC – Tracking area code
Press the [space] key to get to the next screen.
Press the [backspace] key to go to the previous field.

GCell	Chan
xxxxxx	xxxx

Cell Display for LTE

GCell – Global Cell ID
Chan – RF Channel number (EURFCN)
Press the [space] key to go to the next screen.
Press the [backspace] key to go to the previous field.

Band	Mode
xxx	xxxx

LTE Status Display Screen 5

Band – LTE Band Number
Mode – LTE Mode either FDD or TDD
Press the [space] key to go to Status Display Screen 1.
Press the [backspace] key to go to the previous field.

[E]

Operating with 3G service (Applies to HWF2A ONLY)

RAT	RSCP	EC/No
3G	-xxx	-xxxxxx

Signal Display for 3G

RAT – Radio Access Technology.
RSCP –Received Signal Code Power
Ec/N0 – Carrier Noise Ratio (CNR)
Press the [space] key to get to the next screen.
Press the [backspace] key to go to the previous field.

RSCP	MIN	MAX
xxxx	xxxx	xxxx

Min/Max Signal Display for LTE

RSRP – Current Reference Signal Received Power
MIN – Minimum Receive Signal Level
MAX – Maximum Receive Signal Level
Press the [space] key to get to the next screen.
Press the [backspace] key to go to the previous field.

Cntry	Netw	LAC
xxx	xxx	xxxxx

Location Display for 3G

Cntry – Country Code
Netw – Network Code
LAC – Local area code
Press the [space] key to get to the next screen.
Press the [backspace] key to go to the previous field.

Cell	Chan	PSC
xxxxxx	xxxx	xxx

Cell Display for 3G

Cell – Global Cell ID
Chan – Control Channel in use
PSC – Primary Sync Code
Press the [space] key to go to the next screen.
Press the [backspace] key to go to the previous field.

Second Site	RSSI
Available	

3G Status Display Screen 5

Secondary Site RSSI availability. Available or Not Available will be displayed.
Press the [space] key to go to Status Display Screen 1.
Press the [backspace] key to go to the previous field.

[F]

Testing Gateway
Redir 1

Run Network Diagnostic Test

Performs a set of network diagnostics that tests the integrity of the links between the communicator and the various connection points (Redirs) to AlarmNet. Refer to Section 6: *Network Diagnostics*.

System Status Displays

[S]	<div style="border: 1px solid black; padding: 2px; display: inline-block;">ECP</div> <div style="display: inline-block; vertical-align: top; margin-left: 20px;">Flt OK</div>	<p>ECP Mode Displays system fault status.</p> <ul style="list-style-type: none"> • Flt: Represents radio faults • OK: Normal, No fault <ul style="list-style-type: none"> ○ I: No network connectivity over IP and fault time has expired ○ i: No network connectivity over IP and fault time has NOT yet expired. ○ G: No network connectivity over Cell and fault time has expired. ○ g: No network connectivity over Cell and fault time has NOT yet expired. <p>NOTE: The 7720P will not operate if the power line voltage is removed.</p>
[T]	<div style="border: 1px solid black; padding: 2px; display: inline-block;">Test Msg Sent</div>	<p>Test Alarm Sends a Test alarm to AlarmNet. Functional for a <i>registered</i> communicator only. If the device is not registered, a message is displayed indicating that the command cannot be executed.</p>
[X]	<div style="border: 1px solid black; padding: 2px; display: inline-block;">Reset CPU Y/N</div>	<p>Reset the Communicator. Pressing [N] returns to diagnostic mode (blank screen = enter next command or escape). Pressing [Y] resets the communicator (blank screen = reset complete).</p>
[↑] (UP arrow)	<div style="border: 1px solid black; padding: 2px; display: inline-block;">Registering ...</div>	<p>Registration Registers a programmed communicator with AlarmNet.</p>
[↓] (DN arrow)	<div style="border: 1px solid black; padding: 2px; display: inline-block;">Enter PIN#</div>	<p>Registration with PIN for Replacement Communicator Registers a replacement communicator with AlarmNet, once programmed, using the existing PIN #.</p>
[0]	<div style="border: 1px solid black; padding: 2px; display: inline-block;">Force Server Update? Y/N</div>	<p>Force Upload of Configuration File to Server Pressing [Y] will force the device to upload its entire configuration file to the server. Pressing [N] cancels the operation. NOTE: If the internet is not available, and the communicator is not initialized when you enter this command, the following screen will be displayed:</p> <div style="border: 1px solid black; padding: 2px; margin: 10px 0; display: inline-block;">Cannot Upload Try Later! _</div> <p>Wait for the signal quality LEDs to light, indicating the communicator has completed its initialization, and try again.</p>
[ENTER]	<div style="border: 1px solid black; padding: 2px; display: inline-block;">Strt Prog Mode? Y/N_</div>	<p>Enter Program Mode Press [Y] to enter program mode; otherwise, press [N].</p>

Running Network Diagnostics

(available only if the communication path includes IP)

The network diagnostic process tests the integrity of the links between the communicator and the various connection points of AlarmNet Control that are known as "Redirects" (Redirs or RDR).

To initiate the network diagnostics, press the [F] key on the 7720P Programming Tool.

NOTE: The test is performed ONLY if a physical link is detected. If no physical link is detected, the test is aborted and the following is displayed:

NO PHYSICAL LINK

If a physical link is detected, the diagnostics are performed. The following shows the progression of the test:

Testing Redir 1

The first step of the test traces the connection to Redir 1 at AlarmNet Control.

Testing Redir 2
Reached Gateway

A successful trace to Redir 1 is indicated here. See below for possible errors that may occur at this stage of testing.

Redir 1
Service OK

The service at AlarmNet Control on Redir 1 is functioning. See below for possible errors that may occur at this stage of testing.

Testing Redir 2

The first step of the test traces the connection to Redir 2 at AlarmNet Control.

Redir 2
Service OK

The service at AlarmNet Control on Redir 2 is functioning. See below for possible errors that may occur at this stage of testing.

Testing Redir 3

The first step of the test traces the connection to Redir 3 at AlarmNet Control.

Redir 3
Service OK

The service at AlarmNet Control on Redir 3 is functioning. See below for possible errors that may occur at this stage of testing.

RDR1 RDR2 RDR3
OK OK OK

A summary of the tests is displayed after Redir 3 is tested. The example shows that the tests of all three connection points, or Redirs, were successful. If an error occurred at any point, the summary will display "FAIL" under the faulty Redir.

Possible Errors Running Network Diagnostics

Errors may occur either while tracing the connection to a given Redir or while testing the service at a given Redir. The following list highlights the most common errors. Please contact the AlarmNet Technical Assistance Center (TAC) for help regarding any errors NOT listed below:

Possible Errors

Testing Redir x
FAIL before Gtwy

While tracing the connection to Redir x, the trace fails before ever reaching the local gateway (router).

Testing Redir x
FAIL at Gtwy

While tracing the connection to Redir x, the trace fails after reaching the local gateway (router).

Testing Redir x
FAIL at Pvt IP

While tracing the connection to Redir x, the trace fails after reaching the private IP.

Testing Redir x
FAIL on IP Addr

While tracing the connection to Redir x, the trace fails after reaching the public IP.

Redir x
ERR:Proxy 18

After a successful trace to Redir x, the test of the network service timed out without a response.

PowerBoost1 Information

LED Indicator	STATUS
AC (green)	AC power available.
ACTIVE (green)	Cyclical flashing – normal communications. Repetition of 3 flashes – loss of communications.
LOW BATT (yellow)	Missing or low battery.
TROUBLE (yellow)	One or more trouble conditions exist, such as; overload, output supervision, ground fault, or charger failure.

NOTES:

- If AC power is lost and the battery voltage falls below 10v, the PowerBoost1 output voltage will be turned off. The output power is turned back on when AC power is restored.
- You must use the DIP switch settings shown below.

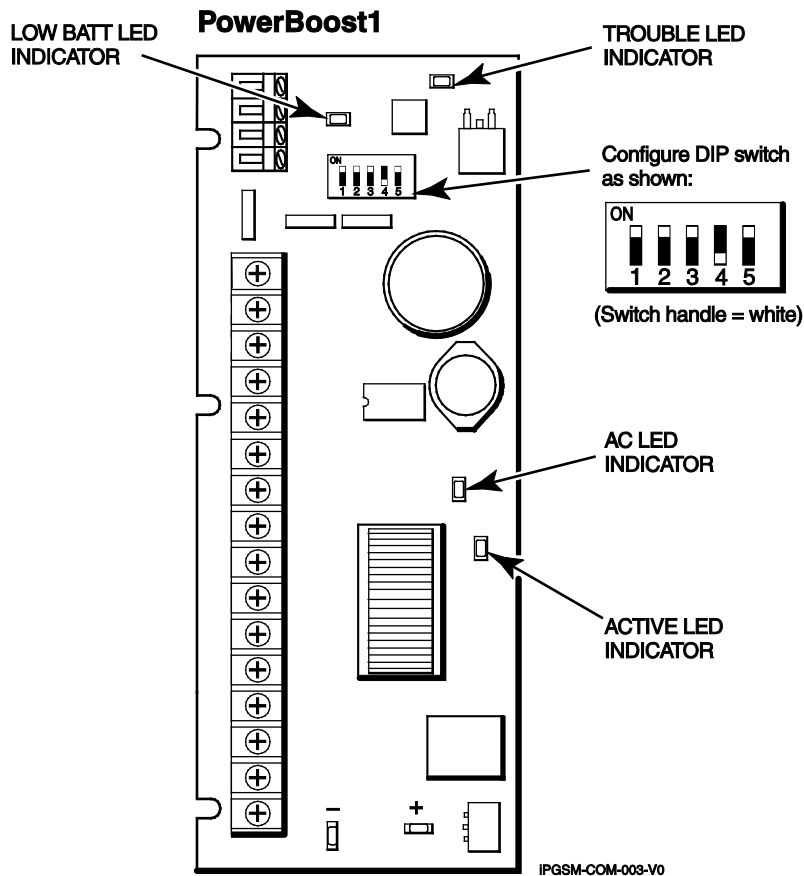

Communicator Information

*** HWF2-COM Initial Power Up:** Upon initial power up, the communicator LEDs blink in repeated sequence from top to bottom indicating network initialization.
 Green (REG) → Yellow (TX/RX) → Red (FAULT)
 This sequence may take up to 15 minutes. **Do not reset power during this time.**
 When initialization is complete, the Signal Quality display LEDs will light and the yellow and red LEDs may blink (per their respective functions).
 After initial network setup, subsequent resets or power ups can take up to 90 seconds.

ON – NOT registered with AlarmNet. OFF – Registered with AlarmNet. FAST BLINK – Download session with Compass in progress. SLOW BLINK – In unison with yellow LED, registration in progress.	GRN
ON – Message transmission pending. QUICK PERIODIC BLINK – Normal. FAST BLINK – Message waiting for network ACK. SLOW BLINK – Idle power abnormal. SLOW BLINK – In unison with green LED, registration in progress.	YEL
ON – No contact with network. OFF – Normal. SLOW BLINK – Loss of communication with the Dialer Capture Module (ECP fault). FAST BLINK – No network contact AND loss of communication with the Dialer Capture Module.	RED

NOTE: if all LEDs FAST BLINK in unison with the signal quality LEDs this indicates a hardware error.

ON – 100 MB/S link to Internet. OFF – 10 MB/S link to Internet.	Link Speed GREEN
ON – Link detected. OFF – No link detected. FAST BLINK – Network activity.	Ethernet Link/Activity GREEN

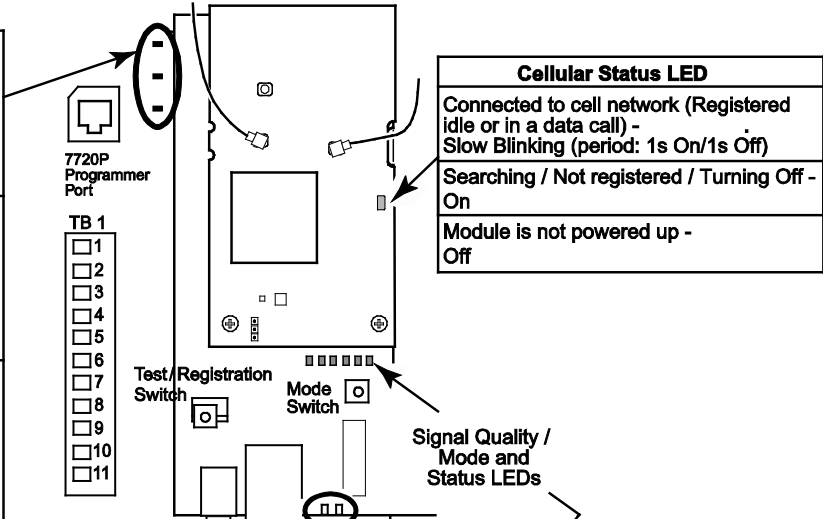

Cellular Status LED
Connected to cell network (Registered idle or in a data call) - Slow Blinking (period: 1s On/1s Off)
Searching / Not registered / Turning Off - On
Module is not powered up - Off

MODULE'S SIGNAL QUALITY		
When the Mode Switch is NOT depressed, LED 1 will illuminate red.		
<ul style="list-style-type: none"> The remaining LEDs indicate Signal Quality. 		
MODULE'S OPERATION MODE		
The HWF2-COM ONLY supports ECP mode to communicate with the built in DCID.		
MODULE'S STATUS		
When the Mode Switch IS depressed, LED 1 will be OFF.		
<ul style="list-style-type: none"> LEDs 4, 5, and 6 indicate the module's Status. 		
LED 4 (green)	LED 5 (green)	LED 6 (green)
ON - Connected to Internet.	ON - Cell service available.	ON - Module registered, no second site available.
OFF - Not connected to Internet.	OFF - No Cell service available.	OFF - Module not registered with network carrier.
	FAST BLINK - Cell in use.	SLOW BLINK - Module registered, second site available, and low signal strength.
		NORMAL BLINK - Module registered, second site available, acceptable signal strength.
		FAST BLINK - Module registered, second site available, excellent signal strength.

HWF2-COM-004-V0

RF Specifications

Frequency Bands							
	LTE Band 2	LTE Band 4	LTE Band 5	LTE Band 12	LTE Band 13	WCDMA Band II	WCDMA Band V
HWF2V	X	X			X		
HWF2A	X	X	X	X	X	X	X
Output Power							
LTE	Class 3	23dBm					
WCDMA	Class 3	24dBm					

IMPORTANT NOTE ABOUT EXTERNAL ANTENNAS

Antenna may only be installed or replaced ONLY by a professional installer.

TO THE INSTALLER

HW2FA-COM: The external antenna gain shall not exceed 6.63 dBi for 700 MHz and 850MHz, 6.00 dBi for 1700 MHz, and 8.51 dBi for 1900 MHz. Under no conditions may an antenna gain be used that would exceed the ERP and EIRP power limits as specified in FCC Parts 22H, 24E and 27.

HW2FV-COM: The external antenna gain shall not exceed 6.94 dBi for 700 MHz 6.00 dBi for 1700 MHz, and 9.01 dBi for 1900 MHz. Under no conditions may an antenna gain be used that would exceed the ERP and EIRP power limits as specified in FCC Parts 22H, 24E and 27.

Central Station Messages

Alarm Condition	Alarm Code	Restore Code
Power On/Reset	E339 C0803	N/A
ECP Supervision (Compromise Indication)	E355 C0000	R355 C0000
Primary Communication Path Supervision	E350 C0951	R350 C0951
Secondary Communication Path Supervision	E350 C0952	R350 C0952
Periodic Cell Comm Path Test Failure (We do not send a restoral R358 C0803, we send a failure message every day after the radio attempts to test and fails.)	E358 C0803	N/A
Application Code Update	E903 C08xx	R903 C08xx (success)
Application Code Update Failure	E904 C08xx	
Module Firmware Update	E365 C08xx	R365 C08xx (success)
Module Firmware Update Failure	E366 C08xx	
Trouble Reporting: The HWF2-COM does not support low/missing battery or AC loss reporting. Power (low/missing battery or AC loss) is monitored by the PB1 module, which triggers the trouble buzzer and turns on the appropriate LED. NOTE: Trouble buzzer sounds during AC Loss only (A Low/missing battery does not trigger the buzzer). <u>HWF2-COM communicator fault</u> The Fire Panel sends out a E380, and E352 message via Telco #1, these are then relayed to the central station via the HWF2-COM. <u>Telco line 1 fault</u> The Fire Panel sends out a E380, and E351 message via Telco #2, these are then relayed to the central station via the HWF2-COM. <u>Telco line 2 fault</u> Fire Panel sends out a E380, and E352 via Telco #1, these are then relayed to the central station via the HWF2-COM.	E380, E351, E352 codes as appropriate.	N/A
Test	5555 5555 9	N/A
AlarmNet Messages		
Communication failure. (Possible Compromise Indication)	E359 0 C950	R359 0 C950
Authorized Radio Substitution	00D0 010C 0	N/A
Unauthorized Radio Substitution Attempt	00D0 010E 0	N/A
Service Termination	00D0 020E 0	N/A

HWF2-COM Trouble Detection Information

Telco 1 is used for the Fire Panel to output contact ID messages to the HWF2-COM, and Telco 2 is used by the HWF2-COM to report faults to the Fire Panel. If Telco 1 is not operational, the Fire Panel will use Telco 2 to report events if there are no faults in the Communicator.

Fault Condition	Indication to Fire Panel
PowerBoost1 fault	Telco 2 is cut.
AC Loss	Telco 2 is cut.
Power Supply fault	Telco 2 is cut.
Low Battery	Telco 2 is cut.
Loss of ECP (Wiring or Addressing)	Telco 1 and 2 are cut.
Radio not registered	Telco 1 and 2 are cut.
Communicator fault	
<ul style="list-style-type: none"> Failure of the communications path when <u>IP only</u> or <u>Cell only</u> is programmed as a communications path. 	Telco 1 and 2 are cut.
<ul style="list-style-type: none"> Failure of both communications paths when IP&Cell is programmed as a communications path. 	Telco 1 and 2 are cut.
<ul style="list-style-type: none"> Failure of one of the communication paths when IP and Cell are enabled as the communications path. 	Telco 2 is cut.
Dialer Capture Module buffer is full.	Hang up. (Panel will retry, giving the buffer a chance to empty.)

HWF2-COM Specifications

ITEM	SPECIFICATION
Cabinet Dimensions:	Width 12 3/4 inches, Height 14 7/8 inches, Depth 3 inches
Transformer: N8167 or N8167-1	Primary – 120VAC, 60Hz, Secondary – 18VAC, 50VA
Battery:	12V, 7Ah sealed lead acid type (not supplied) Use a Honeywell 712BNP, Yuasa NP7-12 or equivalent.
Battery Charging Current:	maximum 1A
Battery Discharge Current:	standby 210mA, active 290mA
Environment:	Operating temperature: 0°C to +49°C Storage temperature: –40° to +70°C Altitude: to 10,000 ft. operating, to 40,000 ft. storage
Supervision:	<p>The Radio (communicator), battery, and AC power, conditions are monitored by the cabinet indicator LEDs:</p> <p>RADIO TROUBLE lights when any of these conditions exist.</p> <ul style="list-style-type: none"> Both IP and Cell communication paths are lost. Communicator radio is not registered. Old Alarm Time has been exceeded. (Message has not been delivered within the fixed 10-minute window.) <p>LOW BATTERY lights when the battery voltage is less than 11.5VDC.</p> <p>AC LOSS lights when the AC power is less than 90VAC.</p>

NOTES

NOTES

NOTES

The wiring diagram below is depicted for point-to-point electrical connection checks used for troubleshooting or component replacement. It is not intended to show the physical routing of wires. When replacing a wire or component, ensure the wire is routed in the same manner as the original factory wire. (**NOTE:** Wire colors may vary.)

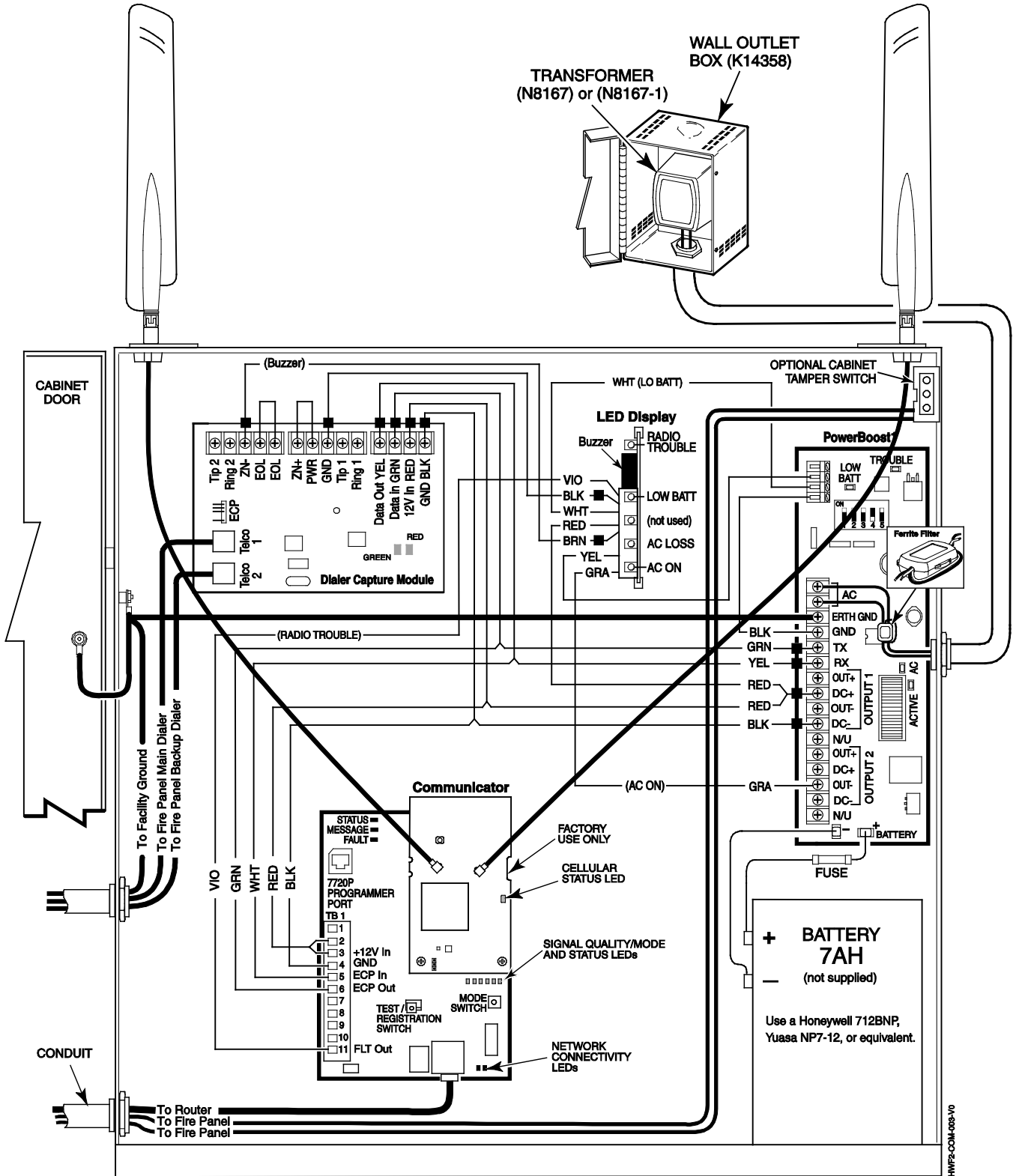

NOTES

- All circuits are power limited except the backup battery which is non-power limited.
- Non-power limited wiring must be separated from the power limited wiring by at least 1/4 inch.
- If desired, use a Honeywell 955WH Tamper Switch with the 28-2 bracket.

FEDERAL COMMUNICATIONS COMMISSION STATEMENTS

The user shall not make any changes or modifications to the equipment unless authorized by the Installation Instructions or User's Manual. Unauthorized changes or modifications could void the user's authority to operate the equipment.

CLASS B DIGITAL DEVICE STATEMENT

This equipment has been tested to FCC requirements and has been found acceptable for use. The FCC requires the following statement for your information:

This equipment generates and uses radio frequency energy and if not installed and used properly, that is, in strict accordance with the manufacturer's instructions, may cause interference to radio and television reception. It has been type tested and found to comply with the limits for a Class B computing device in accordance with the specifications in Part 15 of FCC Rules, which are designed to provide reasonable protection against such interference in a residential installation. However, there is no guarantee that interference will not occur in a particular installation. If this equipment does cause interference to radio or television reception, which can be determined by turning the equipment off and on, the user is encouraged to try to correct the interference by one or more of the following measures:

- Reorient the receiving antenna until interference is reduced or eliminated.
- Move the radio or television receiver away from the receiver/control.
- Move the antenna leads away from any wire runs to the receiver/control.
- Plug the receiver/control into a different outlet so that it and the radio or television receiver are on different branch circuits.
- Consult the dealer or an experienced radio/TV technician for help.

FCC STATEMENT

This device complies with Part 15 of the FCC Rules. Operation is subject to the following two conditions: (1) This device may not cause harmful interference, and (2) This device must accept any interference received, including interference that may cause undesired operation.

Responsible Party / Issuer of Supplier's Declaration of Conformity: Ademco Inc., a subsidiary of Resideo Technologies, Inc., 2 Corporate Center Drive., Melville, NY 11747, Ph: 516-577-2000

RF Exposure

Warning – The antenna(s) used by this product must be installed to provide a separation distance of at least 7.8 in. (20 cm) from all persons and must not be co-located or operating in conjunction with any other antenna or transmitter except in accordance with FCC multi-transmitter product procedures.



The product should not be disposed of with other household waste. Check for the nearest authorized collection centers or authorized recyclers. The correct disposal of end-of-life equipment will help prevent potential negative consequences for the environment and human health.

HONEYWELL POWER SUPPLY SUPPORT AND WARRANTY

Documentation and online support: Please go to <http://www.honeywellpower.com>

Contact Technical Support: (877) HPP-POWR, or Email us at hpp.techserv@honeywell.com

Warranty: For the latest warranty information, please go to:
<https://www.security.honeywellhome.com/hsc/resources/wa/index.html>



800-24452 9/18 Rev B

Honeywell

12 Clintonville Road,
Northford, CT 06472-1610 USA

© 2018 Honeywell International Inc.

www.honeywellpower.com

CALIFORNIA DEPARTMENT OF FORESTRY & FIRE PROTECTION
OFFICE OF THE STATE FIRE MARSHAL
FIRE ENGINEERING - BUILDING MATERIALS LISTING PROGRAM



LISTING SERVICE

LISTING No. 7300-1645:0511 Page 1 of 1

CATEGORY: 7300 -- FIRE ALARM CONTROL UNIT ACCESSORIES/MISC. DEVICES

LISTEE: ADEMCO INC.2 Corporate Center Drive, Melville, NY 11747
Contact: Issa Khouryawa (516) 577-2312 Fax (516) 577-3540
Email: issa.khouryawa@resideo.com

DESIGN: Models HWF2A-COM and HWF2V-Com Commercial Internet and LTE Communicator. The unit uses the Internet as its primary reporting path, and switches to cell service (secondary path as backup) when the Internet is not available. *The units are transmitters that captures DACT communication from a host panel and converts to IP and/or Cellular for transmission to the receiving station. Units also have the option for IP Only or Cellular only without a backup path.
Refer to listee's product specification data sheets and installation, operation, and maintenance manual for detailed product description and operational considerations.

RATING: Primary - 120 VAC, 60 Hz
Secondary - 18 VAC, 5 VA

INSTALLATION: In accordance with listee's printed installation instructions, applicable codes & ordinances and in a manner acceptable to the authority having jurisdiction.

MARKING: Listee's name, model number, electrical rating, and UL label.

APPROVAL: Listed as a control unit accessory for use with separately listed compatible commercial fire alarm control units. Refer to listee's installation Instruction Manual for details.

*Rev 08-01-19 gt



This listing is based upon technical data submitted by the applicant. CSFM Fire Engineering staff has reviewed the test results and/or other data but does not make an independent verification of any claims. This listing is not an endorsement or recommendation of the item listed. This listing should not be used to verify correct operational requirements or installation criteria. Refer to listee's data sheet, installation instructions and/or other

Date Issued: **July 01, 2021**

Listing Expires **June 30, 2022**

Authorized By: **DAVID CASTILLO, M.E., F.P.E.**
Fire Engineering Division